

~~xxxxxx~~ 56:171 Operations Research ~~xxxxxx~~
~~xxxx~~ Midterm Exam - Solutions ~~xxxx~~
~~xxxxxx~~ October 22, 1992 ~~xxxxxx~~

You were required to answer both questions of Part One, and 3 (out of 4) problems from Part Two.

		Possible
Part One:	1. True/False & Multiple Choice	15
	2. Sensitivity analysis (LINDO)	25
Part Two:	3. Simplex method	15
	4. LP duality	15
	5. Transportation problem	15
	6. Project scheduling	<u>15</u>
	total possible:	85 (average was 63 points)

There are two versions of the exam; compare your copy with the first true/false statement to determine your version.)

~~xxxxxx~~ **PART ONE** ~~xxxxxx~~

(1.) **True/False:** Indicate by "+" = "true" or "o" = "false" :

- FALSE a. A "dummy" activity in CPM has duration zero and cannot be on the critical path. *A dummy activity may be on the critical path.*
- TRUE b. In PERT, the total completion time of the project is assumed to be a random variable with a normal distribution.
- FALSE c. In the two-phase simplex method, Phase One computes the optimal dual variables, followed by Phase Two in which the optimal primal variables are computed. *Phase One finds a basic feasible solution, and Phase Two optimizes.*
- TRUE d. During any iteration of the simplex method, if x_j is the variable entering the basis, its value after the pivot is the value of the minimum ratio.
- FALSE e. The revised simplex method usually requires fewer iterations than the ordinary simplex method. *The number of iterations is essentially the same.*
- TRUE f. In a transportation problem, if the total supply exceeds total demand, a "dummy" destination should be defined.
- TRUE g. All tasks on the critical path of a project schedule have their latest start time equal to their earliest start time.
- TRUE h. When maximizing in the simplex method, the value of the objective function increases at every iteration unless a degenerate tableau is encountered.
- FALSE i. A basic solution of an LP is always feasible, but not all feasible solutions are basic. *A basic solution may be infeasible.*
- TRUE j. The assignment problem is a special case of a transportation problem.

Multiple Choice: Write the appropriate letter (a, b, c, or d) in the blank:

- A k. If, in the optimal *primal* solution of an LP problem ($\min cx \text{ st } Ax \leq b, x \geq 0$), constraint #1 is slack, then in the optimal dual solution,
- | | |
|---------------------------------|--|
| a. variable #1 must be zero | c. slack variable for constraint #1 must be zero |
| b. variable #1 must be positive | d. constraint #1 must be slack |
| | e. None of the above |
- C l. If, in the optimal *dual* solution of an LP problem ($\min cx \text{ st } Ax \leq b, x \geq 0$), variable #2 is positive, then in the optimal primal solution,
- | | |
|---------------------------------|--|
| a. variable #2 must be zero | c. slack variable for constraint #2 must be zero |
| b. variable #2 must be positive | d. constraint #2 must be slack |
| | e. None of the above |
- B m. If you make a mistake in choosing the pivot row in the simplex method, the solution in the next tableau
- | | |
|------------------------|--------------------------------------|
| a. will be nonbasic | c. will have a worse objective value |
| b. will be nonfeasible | d. will be degenerate |

- C n. If you make a mistake in choosing the pivot column in the simplex method, the solution in the next tableau
- a. will be nonbasic
b. will be nonfeasible
c. will have a worse objective value
d. will be degenerate
e. None of the above
- D o. If there is a tie in the "minimum-ratio test" of the simplex method, the solution in the next tableau
- a. will be nonbasic
b. will be nonfeasible
c. will have a worse objective value
d. will be degenerate
e. None of the above

(2.) *Sensitivity Analysis in LP.* (Tire Manufacturing Problem)

An automobile tire company has the ability to produce both nylon (N) and fiberglass (G) tires. During the next three months they have agreed to deliver tires as follows:

Date	Nylon	Fiberglass
June 30	4000	1000
July 31	8000	5000
August 31	3000	5000
Total	15000	11000

The company has two presses, a Wheeling machine and a Regal machine, and appropriate molds that can be used to produce these tires, with the following production hours available in the upcoming months:

Month	Wheeling machine	Regal machine
June	700	1500
July	300	400
August	1000	300

The production rates for each machine-and-tire combination, in terms of *hours per tire*, are as follows:

Tire	Wheeling machine	Regal machine
Nylon	0.15	0.16
Fiberglass	0.12	0.14

The variable costs of producing tires are \$5.00 per operating hour, regardless of which machine is being used or which tire is being produced. There is also an inventory-carrying charge of \$0.10 per tire per month. The objective is to minimize the cost of meeting the delivery schedule.

Definition of variables: Variables representing production quantities are named as follows:

MTi = # of tires of type T produced on machine M in month i, where M=W (Wheeling) or R (Regal),
T = N (Nylon) or G (Fiberglass), and i=1 (June), 2 (July), or 3 (August)

Variables representing inventory are named as follows:

ITi = # of tires of type T (N or G) stored at the end of month i (1, 2, or 3)

- a. If the number of Nylon tires which the company has agreed to deliver on July 31 were to increase by 1000, the cost would **increase** by \$ 900.
- b. If the number of Nylon tires which the company has agreed to deliver on August 31 were to increase by 1000, the cost would **increase** by \$ 800.
- c. If the number of hours available on the Wheeling machine in July were to decrease by 10, the cost will increase by \$ 11.67, and the following adjustments should be made in the production schedule:
- # Nylon tires produced in Wheeling machine in June: WN1 **decrease** by 66.67
- # F-Glass tires produced in Wheeling machine in June: WG1 **increase** by 83.33
- # Nylon tires produced in Wheeling machine in July: WN2 **no change**
- # F-Glass tires produced in Wheeling machine in July: WG2 **decrease** by 83.33
- # Nylon tires in storage at end of July: IN2 **no change**
- # of idle hours on the Regal machine in August: **no change**
- (The variable SLK 4 should increase by 10 in order to force 10 units of slack in the constraint.)

- d. Suppose that the production plan is modified in order to produce 10 Nylon tires on the Wheeling machine in July. Then the cost will increase by \$**0.25** and the following adjustments should be made:
- # Nylon tires produced in Wheeling machine in June: WN1 **decrease** by 10
 - # F-Glass tires produced in Wheeling machine in June: WG1 **increase** by 12.5
 - # Nylon tires produced in Wheeling machine in July: WN2 **increase** by 10
 - # F-Glass tires produced in Wheeling machine in July: WG2 **decrease** by 12.5
 - # Nylon tires stored at end of July: IN2 **no change**
 - # of idle hours on the Regal machine in August: **no change**
- (The variable WN2 should increase by 10.)
- e. If the storage cost of Nylon tires at the end of June were to increase by 3¢ per tire (to 13¢), the production plan **should** be modified. (The increase is greater than the ALLOWABLE INCREASE in the cost of IN1.)
- f. If the storage cost of Fiberglass tires at the end of June were to increase by 3¢ per tire (to 13¢), the production plan **should not** be modified. (The increase is less than the ALLOWABLE INCREASE in the cost of IG1.)

~~xxxxxx~~**PART TWO**~~xxxxxx~~

- (3.) **Simplex Method. Simplex Algorithm for LP:** At an intermediate step of the simplex algorithm, the tableau is:

$-z$	x_1	x_2	x_3	x_4	x_5	x_6	RHS
1	0	0	0	-2	0	3	-15
0	0	-2	1	4	0	0	4
0	0	1	0	1	1	-1	0
0	1	0	0	-2	0	-3	3

- (a.) What are the basic variables for this tableau? (circle:) **-Z**, **x_1** , **x_3** , **x_5**
- (b.) What are the current values of the variables?
 $Z = \underline{15}$, $x_1 = \underline{3}$, $x_2 = \underline{0}$, $x_3 = \underline{4}$, $x_4 = \underline{0}$, $x_5 = \underline{0}$, $x_6 = \underline{0}$.
- (c.) Increasing x_4 would **decrease** the objective function.
- (d.) Increasing x_6 would **increase** the objective function.
- (e.) What is the substitution rate of x_4 for x_5 ? 1 That is, if x_4 is increased by 1 unit, x_5 (circle: **decreases**) by a quantity 1.
- (f.) Suppose that x_3 and x_4 are slack variables in the first 2 constraints, and x_5 a surplus variable in the the last constraint. (That is, the first two constraints were originally \leq constraints, and the third was originally a \geq constraint, all converted to equations.) What are the values of the simplex multipliers (dual variables) for this tableau? $u_1 = \underline{0}$, $u_2 = \underline{2}$, $u_3 = \underline{0}$ (Reduced cost of a slack variable is the negative of the dual variable for that constraint.)
- (g.) If the objective is to **maximize** z , the optimal solution is unbounded.
- (h.) If the objective is not that which you specified in (g), perform a pivot to improve the objective function, and write the new tableau below: (Pivot in x_4 column in 3rd row, since minimum ratio is zero.)

-Z	X ₁	X ₂	X ₃	X ₄	X ₅	X ₆	rhs
1	0	2	0	0	2	1	-15
0	0	-6	1	0	-4	4	4
0	0	1	0	1	1	-1	0
0	1	2	0	0	2	-5	3

vvvvvvvvvvvv

(4.) Linear Programming Duality: Consider the following LP:

Minimize $12X_1 + 8X_2$ subject to $3X_1 + 4X_2 = 12$ $5X_1 + 2X_2 = 10$ $X_1 + 2X_2 = 3$ $X_1 \geq 0, X_2 \geq 0$	(with inequalities replaced by equations:) Minimize $12X_1 + 8X_2$ subject to $3X_1 + 4X_2 + X_3 = 12$ $5X_1 + 2X_2 + X_4 = 10$ $X_1 + 2X_2 - X_5 = 3$ $X_j \geq 0, j=1,2,3,4,5$
--	---

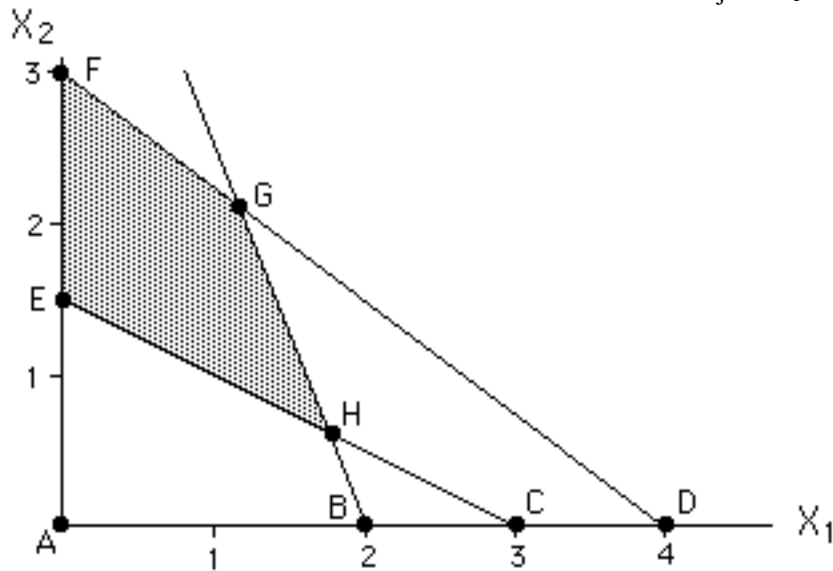

- Which points above are feasible? **E F G H**
- At point E, which variables are basic? (circle:) **X₂ X₃ X₄**
- At point G, which variables are basic? (circle:) **X₁ X₂ X₅**
- Indicate (by shading) the feasible region of the LP.
- Dual LP of the above problem (with inequality constraints):
Max $12Y_1 + 10Y_2 + 3Y_3$
 subject to $3Y_1 + 5Y_2 + Y_3 \leq 12$
 $4Y_1 + 2Y_2 + 2Y_3 \leq 8$
 $Y_1 \geq 0, Y_2 \geq 0, Y_3 \geq 0$
- Dual LP with only equations:
Max $12Y_1 + 10Y_2 + 3Y_3$
 subject to $3Y_1 + 5Y_2 + Y_3 + Y_4 = 12$
 $4Y_1 + 2Y_2 + 2Y_3 + Y_5 = 8$
 $Y_1 \geq 0, Y_2 \geq 0, Y_3 \geq 0, Y_4 \geq 0, Y_5 \geq 0$
- Which point is optimal in the primal problem? **E**

- h. According to the Complementary Slackness Theorem, which variables must be zero at the optimum of the dual LP? Y_1 (since 1st constraint is slack at E), Y_2 (since 2nd constraint is slack at E) and Y_5 (since X_2 is positive at E).
- i. The optimal dual solution is: $Y_1 = 0$, $Y_2 = 0$, $Y_3 = 4$, $Y_4 = 8$, $Y_5 = 0$, (found by solving the two dual constraints for the two remaining dual variables which are not zero.)

vvvvvvvvvvvv

(5.) **Transportation Problem:** Consider the transportation problem with the tableau below:

	D	E	F	G	supply
A	3 3	2 1	2 2	4 4	5
B	5 5	1 2	2 3	1 6	4
C	2 2	1 1	1 1	2 3	2
	demand 3	3	2	3	

- a. If the ordinary simplex tableau were to be written for this problem, it would have 7 rows, plus the objective row, and 12 columns (in addition to -z and the right-hand-side).
- b. This problem will have 6 basic variables (plus -z). (because one constraint is redundant.)
- c. Find an initial basic feasible solution using the "Northwest Corner Method" (values of the variables in the tableau above.)
- d. What are the values of the dual variables for the solution in (c)? $U_A = 0$, $U_B = 1$, $U_C = -2$, $V_D = 3$, $V_E = 1$, $V_F = 2$, $V_G = 5$. (Other solutions are possible, depending upon the value initially assigned to one of the variables... here I assigned 0 to U_A .)
- e. What is the reduced cost of the variable X_{BD} ? 1 ... of the variable X_{AG} ? -1
- f. Will increasing X_{BD} improve the objective function? no (since its reduced cost is >0 .)
- g. Regardless of whether the answer to (f) is "yes" or "no", what variable must leave the basis if X_{BD} enters? X_{BE}
- h. What will be the value of X_{BD} if it is entered into the solution as in (g)? 1
- i. Which variable, if it were entered into the solution, would result in a degenerate solution? X_{AF}

vvvvvvvvvvvv

(6.) **Project Scheduling.** Consider the project with the A-O-A (activity-on-arrow) network given below.

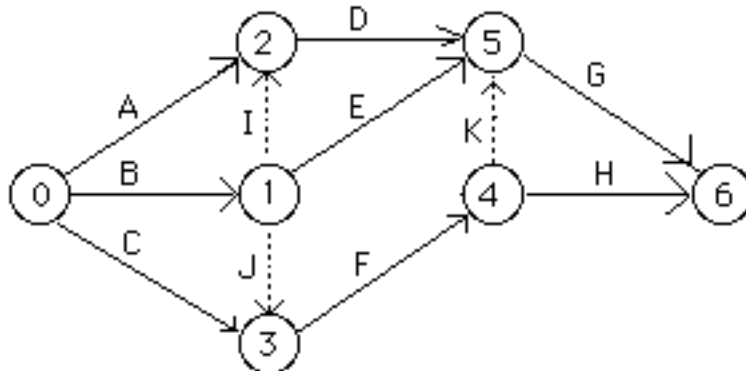

- a. How many activities (i.e., tasks), not including "dummies", are required to complete this project? 8
- b. Complete the labeling of the nodes on the network above. (The labels of nodes 2 & 3 could have been switched.)
- c. The activity durations are given below on the arrows. Compute the Early Times (ET) and Late Times (LT) for each node, writing them in the box (with rounded corners) beside each node.

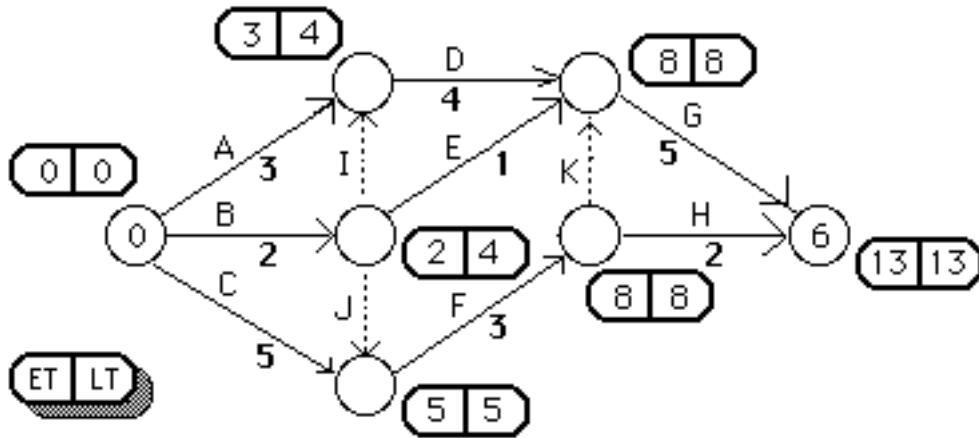

- d. Find the slack ("total float") for activity B. 2
- e. Which activities are critical? **C F G K**
- f. What is the earliest completion time for the project? 13
- g. Indicate by X which of the following constraint(s) would appear in the LP formulation of this problem:

<input type="checkbox"/>	$Y_F - Y_A \leq 3$	<input type="checkbox"/>	$Y_F - Y_B \leq 3$	<input type="checkbox"/>	$Y_F - Y_C \leq 3$
<input type="checkbox"/>	$Y_F - Y_A \leq 2$	<input checked="" type="checkbox"/>	$Y_F - Y_B \leq 2$	<input checked="" type="checkbox"/>	$Y_F - Y_C \leq 5$
- h. Complete the A-O-N (activity-on-node) network below for this same project. (Add any "dummy" activities which are necessary.)

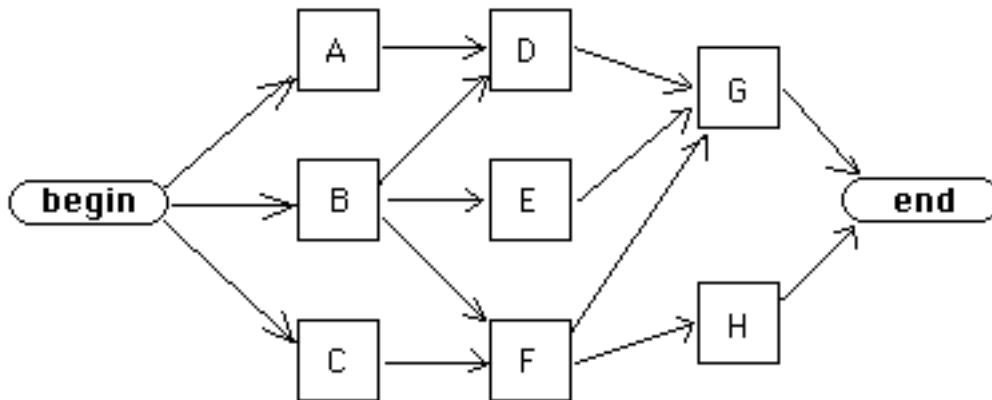

- h. Suppose that the arrow labelled "K" is deleted. Indicate the resulting A-O-N network below:

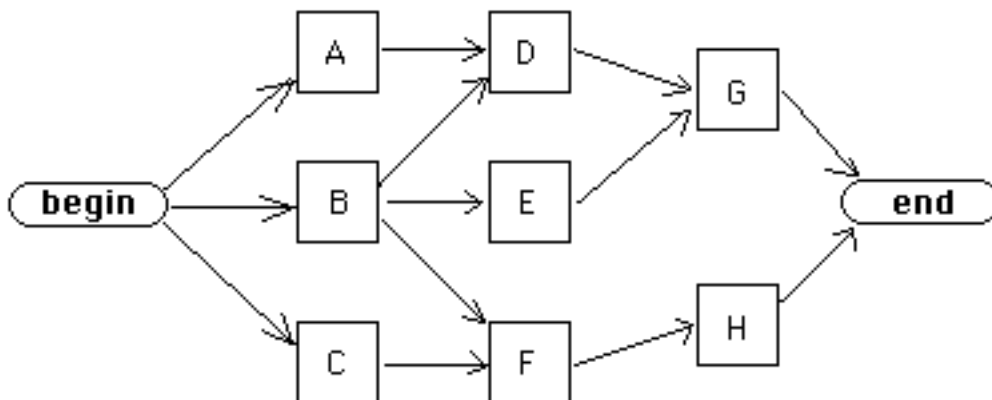

~~zzzzzz~~ **Version Two PART ONE** ~~zzzzzz~~

(1.) & (2.) See answers in Version One. Only the order of the questions was changed.

~~zzzzzz~~ **Version Two PART TWO** ~~zzzzzz~~

(3.) **Simplex Method. Simplex Algorithm for LP:** At an intermediate step of the simplex algorithm, the tableau is:

-z	x ₁	x ₂	x ₃	x ₄	x ₅	x ₆	RHS
1	2	0	0	0	0	-3	-15
0	4	-2	1	0	0	0	4
0	1	1	0	1	0	-1	0
0	-2	0	0	0	1	-3	3

- (a.) Basic variables for this tableau: **-Z, X₃, X₄, & X₅**
- (b.) Current values of the variables?
 $Z = \underline{15}$, $X_1 = \underline{0}$, $X_2 = \underline{0}$, $X_3 = \underline{4}$, $X_4 = \underline{0}$, $X_5 = \underline{3}$, $X_6 = \underline{0}$.
- (c.) Increasing X₁ would **increase** the objective function.
- (d.) Increasing X₆ would **decrease** the objective function.
- (e.) The substitution rate of X₁ for X₃: 4 That is, if X₁ is increased by 1 unit, X₃ **decreases** by a quantity 4.
- (f.) Suppose that X₃ and X₄ are slack variables in the first 2 constraints, and X₅ a surplus variable in the the last constraint. (That is, the first two constraints were originally constraints, and the third was originally a constraint, all converted to equations.) What are the values of the simplex multipliers (dual variables) for this tableau? $\lambda_1 = \underline{0}$, $\lambda_2 = \underline{0}$, $\lambda_3 = \underline{0}$ (Since reduced cost of a slack/surplus variable is - / + simplex multiplier, or dual variable.)
- (g.) If the objective is to **minimize** z, the optimal solution is unbounded.
- (h.) If the objective is not that which you specified in (g), perform a pivot to improve the objective function, and write the new tableau below: (Minimum ratio is 0/1=0)

-Z	x ₁	x ₂	x ₃	x ₄	x ₅	x ₆	rhs
1	0	-2	0	-2	0	-1	-15
0	0	-6	1	-4	0	4	4
0	1	1	0	1	0	-1	0
0	0	2	0	2	1	-5	3

vvvvvvvvvvvv

(4.) **Linear Programming Duality:** Consider the following LP:

Minimize $12X_1 + 8X_2$ subject to $3X_1 + 4X_2 = 12$ $5X_1 + 2X_2 = 10$ $X_1 + 2X_2 = 3$ $X_1, X_2 \geq 0$	(with inequalities replaced by equations:) Minimize $12X_1 + 8X_2$ subject to $3X_1 + 4X_2 + X_3 = 12$ $5X_1 + 2X_2 - X_4 = 10$ $X_1 + 2X_2 - X_5 = 3$ $X_j \geq 0, j=1,2,3,4,5$
---	---

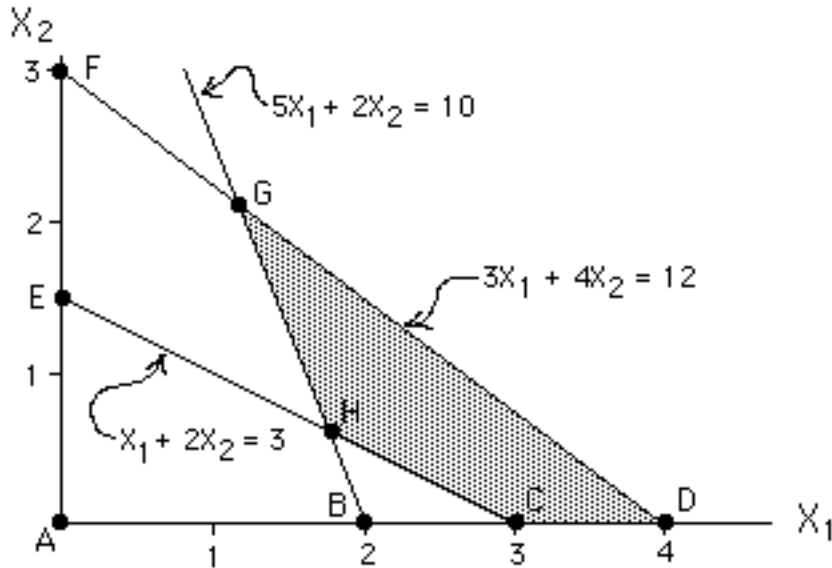

- Which points above are feasible? **C D G H**
- At point G, which variables are basic? **X₁, X₂, & X₅**
- At point C, which variables are basic? **X₁, X₃, & X₄**
- Indicate (by shading) the feasible region of the LP.
- The dual LP of the above problem (with inequality constraints):
Max $12Y_1 + 10Y_2 + 3Y_3$
 subject to $3Y_1 + 5Y_2 + Y_3 \leq 12$
 $4Y_1 + 2Y_2 + 2Y_3 \leq 8$
 $Y_1 \geq 0, Y_2 \geq 0, Y_3 \geq 0$
- The dual LP with only equations:
Max $12Y_1 + 10Y_2 + 3Y_3$
 subject to $3Y_1 + 5Y_2 + Y_3 + Y_4 = 12$
 $4Y_1 + 2Y_2 + 2Y_3 + Y_5 = 8$
 $Y_1 \geq 0, Y_2 \geq 0, Y_3 \geq 0, Y_4 \geq 0, Y_5 \geq 0$
- Which point is optimal in the primal problem? **H**
- According to the Complementary Slackness Theorem, which variables must be zero at the optimum of the dual LP? **Y₁** (because 1st constraint is slack), **Y₄**, & **Y₅** (because X₁ and X₂ are both >0),
- The optimal dual solution is: Y₁ = 0, Y₂ = 2, Y₃ = 2, Y₄ = 0, Y₅ = 0, (found by solving the 2 dual equations for the two remaining variables Y₂ and Y₃.)

vvvvvvvvvvvv

(5.) **Transportation Problem:** Consider the transportation problem with the tableau below:

	D	E	F	G	supply
A	3 5	1 1	2 2	4 4	4
B	3 3	1 2	3 3	1 6	5
C	2 2	1 1	1 1	2 1	2
	demand 3	2	3	3	

- If the ordinary simplex tableau were to be written for this problem, it would have 7 rows, plus the objective row, and 12 columns (in addition to -z and the right-hand-side).

- b. This problem will have 6 basic variables (plus -z). (Because one constraint is redundant.)
- c. Find an initial basic feasible solution using the "Northwest Corner Method" (values of the variables in the tableau above.)
- d. What are the values of the dual variables for the solution in (c)? $U_A = \underline{0}$, $U_B = \underline{1}$, $U_C = \underline{-4}$, $V_D = \underline{5}$, $V_E = \underline{1}$, $V_F = \underline{2}$, $V_G = \underline{5}$. (Other solutions are possible, depending upon the value initially assigned to one of the variables... here I assigned 0 to U_A .)
- e. What is the reduced cost of the variable X_{BD} ? -3 ... of the variable X_{AG} ? -1
- f. Will increasing X_{BD} improve the objective function? yes
- g. Regardless of whether the answer to (f) is "yes" or "no", what variable must leave the basis if X_{BD} enters? X_{BE}
- h. What will be the value of X_{BD} if it is entered into the solution as in (g)? 1
- i. Which variable, if it were entered into the solution, would result in a degenerate solution? (none of these variables: X_{AF} X_{CD} X_{CE}) (variable X_{AG} would, but is not in the list which was provided.)

XXXXXXXXXXXX

(6.) **Project Scheduling.** Consider the project with the A-O-A (activity-on-arrow) network given below.

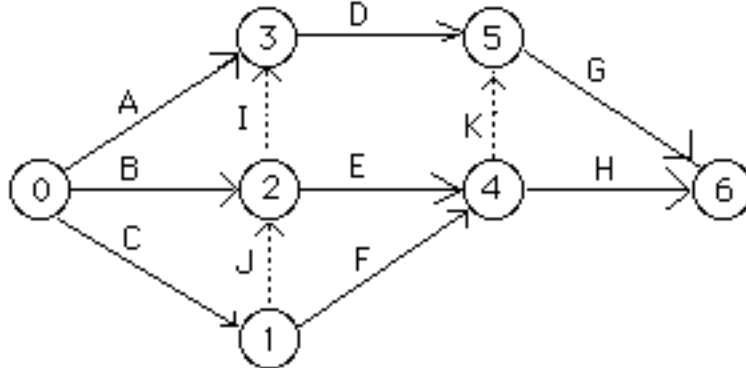

- a. How many activities (i.e., tasks), not including "dummies", are required to complete this project? 8
- b. Labeling of the nodes on the network above.
- c. The activity durations are given below on the arrows. Compute the Early Times (ET) and Late Times (LT) for each node, writing them in the box (with rounded corners) beside each node.

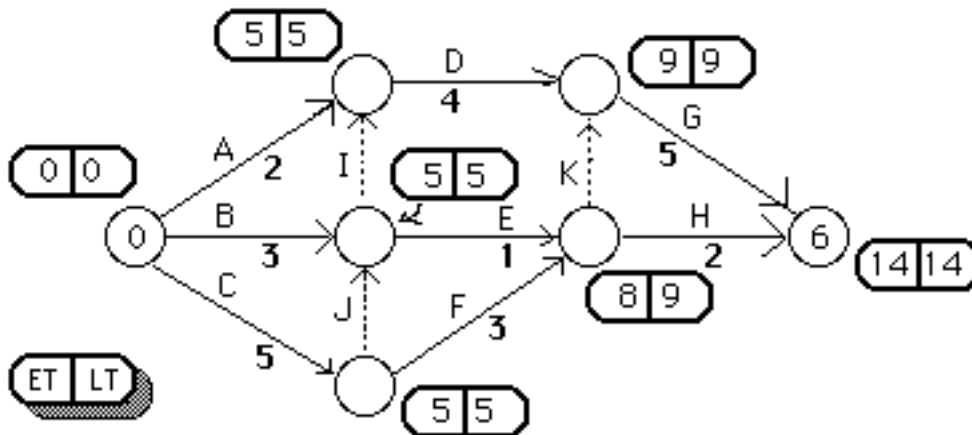

- d. Slack ("total float") for activity B: 2
- e. Activities which are critical: C, D, G, I, & J
- f. Earliest completion time for the project: 14
- g. Indicate by X which of the following constraint(s) would appear in the LP formulation of this problem:

_____	$Y_E - Y_A$	1	_____	$Y_E - Y_B$	1	_____	$Y_E - Y_C$	1
_____	$Y_E - Y_A$	2	<u> X </u>	$Y_E - Y_B$	3	<u> X </u>	$Y_E - Y_C$	5

h. Complete the A-O-N (activity-on-node) network below for this same project. (Add any "dummy" activities which are necessary.)

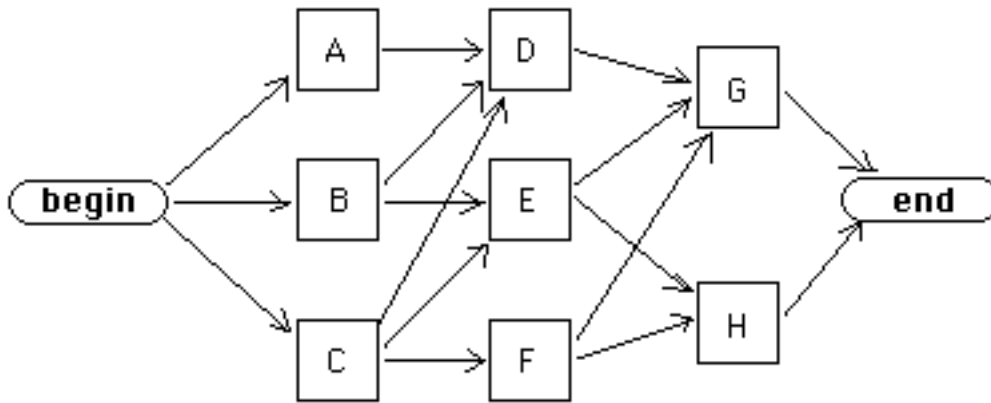

h. Suppose that the arrow labelled "K" is deleted. Indicate the resulting A-O-N network below:

