Specification for Structural Steel Buildings

March 9, 2005

Supersedes the *Load and Resistance Factor Design Specification for Structural Steel Buildings* dated December 27, 1999, the *Specification for Structural Steel Buildings—Allowable Stress Design and Plastic Design* dated June 1, 1989, including Supplement No. 1, the *Specification for Allowable Stress Design of Single-Angle Members* dated June 1, 1989, the *Load and Resistance Factor Design Specification for Single-Angle Members* dated November 10, 2000, and the *Load and Resistance Factor Design Specification for the Design of Steel Hollow Structural Sections* dated November 10, 2000, and all previous versions of these specifications.

Approved by the AISC Committee on Specifications and issued by the
AISC Board of Directors



AMERICAN INSTITUTE OF STEEL CONSTRUCTION, INC.

One East Wacker Drive, Suite 700
Chicago, Illinois 60601-1802

Copyright © 2005

by

American Institute of Steel Construction, Inc.

*All rights reserved. This book or any part thereof
must not be reproduced in any form without the
written permission of the publisher.*

The information presented in this publication has been prepared in accordance with recognized engineering principles and is for general information only. While it is believed to be accurate, this information should not be used or relied upon for any specific application without competent professional examination and verification of its accuracy, suitability, and applicability by a licensed professional engineer, designer, or architect. The publication of the material contained herein is not intended as a representation or warranty on the part of the American Institute of Steel Construction or of any other person named herein, that this information is suitable for any general or particular use or of freedom from infringement of any patent or patents. Anyone making use of this information assumes all liability arising from such use.

Caution must be exercised when relying upon other specifications and codes developed by other bodies and incorporated by reference herein since such material may be modified or amended from time to time subsequent to the printing of this edition. The Institute bears no responsibility for such material other than to refer to it and incorporate it by reference at the time of the initial publication of this edition.

Printed in the United States of America

DEDICATION



Professor Lynn S. Beedle

This edition of the AISC Specification is dedicated to the memory of Dr. Lynn S. Beedle, University Distinguished Professor at Lehigh University. Dr. Beedle served as a faculty member at Lehigh University for 41 years and won a very large number of professional and educational awards, including the 1973 T.R. Higgins Award and the 2003 Geerhard Haaijer Award from AISC. He was a major contributor to several editions of the AISC Specification and a long-time member of the AISC Committee on Specifications. He was instrumental in the development of plastic design methodologies and its implementation into the AISC Specification. He was Director of the Structural Stability Research Council for 25 years, and in that role fostered understanding of various stability problems and helped develop rational design provisions, many of which were adopted in the AISC Specifications. In 1969, he founded the Council on Tall Buildings and Urban Habitat and succeeded in bringing together the disciplines of architecture, structural engineering, construction, environment, sociology and politics, which underlie every major tall building project. He was actively involved in this effort until his death in late 2003 at the age of 85. His contributions to the design and construction of steel buildings will long be remembered by AISC, the steel industry and the structural engineering profession worldwide.

For a more complete discussion of Dr. Beedle's life and accomplishments, see *Catalyst for Skyscraper Revolution: Lynn S. Beedle—A Legend in his Lifetime* by Mir Ali, published by the Council on Tall Buildings and Urban Habitat (2004).

PREFACE

(This Preface is not part of ANSI/AISC 360-05, *Specification for Structural Steel Buildings*, but is included for informational purposes only.)

This Specification has been based upon past successful usage, advances in the state of knowledge, and changes in design practice. The 2005 American Institute of Steel Construction's *Specification for Structural Steel Buildings* for the first time provides an integrated treatment of Allowable Stress Design (ASD) and Load and Resistance Factor Design (LRFD), and thus combines and replaces earlier Specifications that treated the two design methods separately. As indicated in Chapter B of the Specification, designs can be made according to either ASD or LRFD provisions.

This Specification has been developed as a consensus document to provide a uniform practice in the design of steel-framed buildings and other structures. The intention is to provide design criteria for routine use and not to provide specific criteria for infrequently encountered problems, which occur in the full range of structural design.

This Specification is the result of the consensus deliberations of a committee of structural engineers with wide experience and high professional standing, representing a wide geographical distribution throughout the United States. The committee includes approximately equal numbers of engineers in private practice and code agencies, engineers involved in research and teaching, and engineers employed by steel fabricating and producing companies. The contributions and assistance of more than 50 additional professional volunteers working in ten task committees are also hereby acknowledged.

The Symbols, Glossary and Appendices to this Specification are an integral part of the Specification. A non-mandatory Commentary has been prepared to provide background for the Specification provisions and the user is encouraged to consult it. Additionally, non-mandatory User Notes are interspersed throughout the Specification to provide concise and practical guidance in the application of the provisions.

The reader is cautioned that professional judgment must be exercised when data or recommendations in the Specification are applied, as described more fully in the disclaimer notice preceding this Preface.

This Specification was approved by the Committee on Specifications,

James M. Fisher, Chairman	Tony C. Hazel
Roger E. Ferch, Vice Chairman	Mark V. Holland
Hansraj G. Ashar	Lawrence A. Kloiber
William F. Baker	Roberto T. Leon
John M. Barsom	Stanley D. Lindsey
William D. Bast	James O. Malley
Reidar Bjorhovde	Richard W. Marshall (deceased)
Roger L. Brockenbrough	Harry W. Martin
Gregory G. Deierlein	David L. McKenzie
Duane S. Ellifritt	Duane K. Miller
Bruce R. Ellingwood	Thomas M. Murray
Michael Engelhardt	R. Shankar Nair
Shu-Jin Fang	Jack E. Petersen
Steven J. Fennes	Douglas A. Rees-Evans
John W. Fisher	Robert E. Shaw, Jr.
Timothy P. Fraser	Donald R. Sherman
Theodore V. Galambos	W. Lee Shoemaker
Louis F. Geschwindner	William A. Thornton
Lawrence G. Griffis	Raymond H. R. Tide
John L. Gross	Cynthia J. Duncan, Secretary

The Committee gratefully acknowledges the following task committee members for their contribution to this document.

Farid Alfawakhiri	Christopher Hewitt
Georges Axmann	Ronald Hiatt
Joseph Bohinsky	Keith Hjelmstad
Bruce Butler	Socrates Ioannides
Charles Carter	Nestor Iwankiw
Robert Dexter (deceased)	Richard Kaehler
Carol Drucker	Dean Krouse
W. Samuel Easterling	Barbara Lane
Michael Engestrom	Jay Larson
M. Thomas Ferrell	Michael Lederle
Christopher Foley	Kevin LeSmith
Arvind Goverdhan	J. Walter Lewis
Jerome Hajar	Daniel Linzell
Tom Harrington	LeRoy Lutz
James Harris	Peter Marshall
Steven Herth	Brian Meacham
Todd Helwig	Saul Mednick
Richard Henige	James Milke

Heath Mitchell
Jeffrey Packer
Frederick Palmer
Dhiren Panda
Teoman Pekoz
Carol Pivonka
Clinton Rex
John Ruddy
David Samuelson
Thomas Schlafly

James Swanson
Emile Troup
Chia-Ming Uang
Sriramulu Vinnakota
Robert Weber
Donald White
Robert Wills
Ronald Ziemian
Sergio Zoruba

TABLE OF CONTENTS

SYMBOLS	xxix
GLOSSARY	xliii
SPECIFICATION	
A. GENERAL PROVISIONS	1
A1. Scope	1
1. Low-Seismic Applications	2
2. High-Seismic Applications	2
3. Nuclear Applications	2
A2. Referenced Specifications, Codes and Standards	2
A3. Material	5
1. Structural Steel Materials	5
1a. ASTM Designations	6
1b. Unidentified Steel	7
1c. Rolled Heavy Shapes	7
1d. Built-Up Heavy Shapes	7
2. Steel Castings and Forgings	7
3. Bolts, Washers and Nuts	8
4. Anchor Rods and Threaded Rods	8
5. Filler Metal and Flux for Welding	9
6. Stud Shear Connectors	9
A4. Structural Design Drawings and Specifications	9
B. DESIGN REQUIREMENTS	10
B1. General Provisions	10
B2. Loads and Load Combinations	10
B3. Design Basis	10
1. Required Strength	10
2. Limit States	11
3. Design for Strength Using Load and Resistance Factor Design (LRFD)	11
4. Design for Strength Using Allowable Strength Design (ASD)	11
5. Design for Stability	12
6. Design of Connections	12
6a. Simple Connections	12
6b. Moment Connections	12
7. Design for Serviceability	12
8. Design for Ponding	13
9. Design for Fatigue	13
10. Design for Fire Conditions	13
11. Design for Corrosion Effects	13

12. Design Wall Thickness for HSS	13
13. Gross and Net Area Determination	14
B4. Classification of Sections for Local Buckling	14
1. Unstiffened Elements	15
2. Stiffened Elements	15
B5. Fabrication, Erection and Quality Control	18
B6. Evaluation of Existing Structures	18
C. STABILITY ANALYSIS AND DESIGN	19
C1. Stability Design Requirements	19
1. General Requirements	19
2. Member Stability Design Requirements	19
3. System Stability Design Requirements	20
3a. Braced-Frame and Shear-Wall Systems	20
3b. Moment-Frame Systems	20
3c. Gravity Framing Systems	20
3d. Combined Systems	20
C2. Calculation of Required Strengths	20
1. Methods of Second-Order Analysis	21
1a. General Second-Order Elastic Analysis	21
1b. Second-Order Analysis by Amplified First-Order Elastic Analysis	21
2. Design Requirements	23
2a. Design by Second-Order Analysis	23
2b. Design by First-Order Analysis	24
D. DESIGN OF MEMBERS FOR TENSION	26
D1. Slenderness Limitations	26
D2. Tensile Strength	26
D3. Area Determination	27
1. Gross Area	27
2. Net Area	27
3. Effective Net Area	28
D4. Built-Up Members	28
D5. Pin-Connected Members	28
1. Tensile Strength	28
2. Dimensional Requirements	30
D6. Eyebars	30
1. Tensile Strength	30
2. Dimensional Requirements	30
E. DESIGN OF MEMBERS FOR COMPRESSION	32
E1. General Provisions	32
E2. Slenderness Limitations and Effective Length	32
E3. Compressive Strength for Flexural Buckling of Members without Slender Elements	33

E4.	Compressive Strength for Torsional and Flexural-Torsional Buckling of Members without Slender Elements	34
E5.	Single Angle Compression Members	35
E6.	Built-Up Members	37
	1. Compressive Strength	37
	2. Dimensional Requirements	37
E7.	Members with Slender Elements	39
	1. Slender Unstiffened Elements, Q_s	40
	2. Slender Stiffened Elements, Q_a	42
F.	DESIGN OF MEMBERS FOR FLEXURE	44
F1.	General Provisions	46
F2.	Doubly Symmetric Compact I-Shaped Members and Channels Bent about their Major Axis	47
	1. Yielding	47
	2. Lateral-Torsional Buckling	47
F3.	Doubly Symmetric I-Shaped Members with Compact Webs and Noncompact or Slender Flanges Bent about Their Major Axis	49
	1. Lateral-Torsional Buckling	49
	2. Compression Flange Local Buckling	49
F4.	Other I-Shaped Members with Compact or Noncompact Webs, Bent about Their Major Axis	49
	1. Compression Flange Yielding	50
	2. Lateral-Torsional Buckling	50
	3. Compression Flange Local Buckling	52
	4. Tension Flange Yielding	52
F5.	Doubly Symmetric and Singly Symmetric I-Shaped Members with Slender Webs Bent about Their Major Axis	53
	1. Compression Flange Yielding	53
	2. Lateral-Torsional Buckling	53
	3. Compression Flange Local Buckling	54
	4. Tension Flange Yielding	54
F6.	I-Shaped Members and Channels Bent about Their Minor Axis	54
	1. Yielding	54
	2. Flange Local Buckling	55
F7.	Square and Rectangular HSS and Box-Shaped Members	55
	1. Yielding	55
	2. Flange Local Buckling	55
	3. Web Local Buckling	56
F8.	Round HSS	56
	1. Yielding	56
	2. Local Buckling	56
F9.	Tees and Double Angles Loaded in the Plane of Symmetry	57
	1. Yielding	57

2.	Lateral-Torsional Buckling	57
3.	Flange Local Buckling of Tees	57
F10.	Single Angles	57
1.	Yielding	58
2.	Lateral-Torsional Buckling	58
3.	Leg Local Buckling	59
F11.	Rectangular Bars and Rounds	60
1.	Yielding	60
2.	Lateral-Torsional Buckling	60
F12.	Unsymmetrical Shapes	61
1.	Yielding	61
2.	Lateral-Torsional Buckling	61
3.	Local Buckling	61
F13.	Proportions of Beams and Girders	61
1.	Hole Reductions	61
2.	Proportioning Limits for I-Shaped Members	62
3.	Cover Plates	62
4.	Built-Up Beams	63
G.	DESIGN OF MEMBERS FOR SHEAR	64
G1.	General Provisions	64
G2.	Members with Unstiffened or Stiffened Webs	64
1.	Nominal Shear Strength	64
2.	Transverse Stiffeners	66
G3.	Tension Field Action	66
1.	Limits on the Use of Tension Field Action	66
2.	Nominal Shear Strength with Tension Field Action	67
3.	Transverse Stiffeners	67
G4.	Single Angles	68
G5.	Rectangular HSS and Box Members	68
G6.	Round HSS	68
G7.	Weak Axis Shear in Singly and Doubly Symmetric Shapes	68
G8.	Beams and Girders with Web Openings	69
H.	DESIGN OF MEMBERS FOR COMBINED FORCES AND TORSION	70
H1.	Doubly and Singly Symmetric Members Subject to Flexure and Axial Force	70
1.	Doubly and Singly Symmetric Members in Flexure and Compression	70
2.	Doubly and Singly Symmetric Members in Flexure and Tension	71
3.	Doubly Symmetric Members in Single Axis Flexure and Compression	72
H2.	Unsymmetric and Other Members Subject to Flexure and Axial Force . . .	73

H3.	Members Under Torsion and Combined Torsion, Flexure, Shear and/or Axial Force	74
1.	Torsional Strength of Round and Rectangular HSS	74
2.	HSS Subject to Combined Torsion, Shear, Flexure and Axial Force	75
3.	Strength of Non-HSS Members under Torsion and Combined Stress	76
I.	DESIGN OF COMPOSITE MEMBERS	77
II.	General Provisions	77
1.	Nominal Strength of Composite Sections	77
1a.	Plastic Stress Distribution Method	77
1b.	Strain-Compatibility Method	78
2.	Material Limitations	78
3.	Shear Connectors	78
I2.	Axial Members	78
1.	Encased Composite Columns	79
1a.	Limitations	79
1b.	Compressive Strength	79
1c.	Tensile Strength	80
1d.	Shear Strength	80
1e.	Load Transfer	80
1f.	Detailing Requirements	81
1g.	Strength of Stud Shear Connectors	81
2.	Filled Composite Columns	81
2a.	Limitations	81
2b.	Compressive Strength	82
2c.	Tensile Strength	82
2d.	Shear Strength	82
2e.	Load Transfer	82
2f.	Detailing Requirements	83
I3.	Flexural Members	83
1.	General	83
1a.	Effective Width	83
1b.	Shear Strength	83
1c.	Strength During Construction	83
2.	Strength of Composite Beams with Shear Connectors	83
2a.	Positive Flexural Strength	83
2b.	Negative Flexural Strength	84
2c.	Strength of Composite Beams with Formed Steel Deck	84
2d.	Shear Connectors	85
3.	Flexural Strength of Concrete-Encased and Filled Members	88
I4.	Combined Axial Force and Flexure	89
I5.	Special Cases	89

J.	DESIGN OF CONNECTIONS	90
J1.	General Provisions	90
	1. Design Basis	90
	2. Simple Connections	90
	3. Moment Connections	91
	4. Compression Members with Bearing Joints	91
	5. Splices in Heavy Sections	91
	6. Beam Copes and Weld Access Holes	92
	7. Placement of Welds and Bolts	92
	8. Bolts in Combination with Welds	92
	9. High-Strength Bolts in Combination with Rivets	93
	10. Limitations on Bolted and Welded Connections	93
J2.	Welds	93
	1. Groove Welds	93
	1a. Effective Area	93
	1b. Limitations	95
	2. Fillet Welds	95
	2a. Effective Area	95
	2b. Limitations	95
	3. Plug and Slot Welds	97
	3a. Effective Area	97
	3b. Limitations	97
	4. Strength	98
	5. Combination of Welds	101
	6. Filler Metal Requirements	102
	7. Mixed Weld Metal	102
J3.	Bolts and Threaded Parts	102
	1. High-Strength Bolts	102
	2. Size and Use of Holes	105
	3. Minimum Spacing	106
	4. Minimum Edge Distance	106
	5. Maximum Spacing and Edge Distance	106
	6. Tension and Shear Strength of Bolts and Threaded Parts	108
	7. Combined Tension and Shear in Bearing-Type Connections	109
	8. High-Strength Bolts in Slip-Critical Connections	109
	9. Combined Tension and Shear in Slip-Critical Connections	110
	10. Bearing Strength at Bolt Holes	111
	11. Special Fasteners	111
	12. Tension Fasteners	111
J4.	Affected Elements of Members and Connecting Elements	111
	1. Strength of Elements in Tension	112
	2. Strength of Elements in Shear	112
	3. Block Shear Strength	112
	4. Strength of Elements in Compression	113

J5.	Fillers	113
J6.	Splices	114
J7.	Bearing Strength	114
J8.	Column Bases and Bearing on Concrete	114
J9.	Anchor Rods and Embedments	115
J10.	Flanges and Webs with Concentrated Forces	115
	1. Flange Local Bending	116
	2. Web Local Yielding	116
	3. Web Crippling	117
	4. Web Sidesway Buckling	117
	5. Web Compression Buckling	119
	6. Web Panel Zone Shear	119
	7. Unframed Ends of Beams and Girders	120
	8. Additional Stiffener Requirements for Concentrated Forces	120
	9. Additional Doubler Plate Requirements for Concentrated Forces	121
K.	DESIGN OF HSS AND BOX MEMBER CONNECTIONS	122
K1.	Concentrated Forces on HSS	122
	1. Definitions of Parameters	122
	2. Limits of Applicability	122
	3. Concentrated Force Distributed Transversely	123
	3a. Criterion for Round HSS	123
	3b. Criteria for Rectangular HSS	123
	4. Concentrated Force Distributed Longitudinally at the Center of the HSS Diameter or Width, and Acting Perpendicular to the HSS Axis	124
	4a. Criterion for Round HSS	125
	4b. Criterion for Rectangular HSS	125
	5. Concentrated Force Distributed Longitudinally at the Center of the HSS Width, and Acting Parallel to the HSS Axis	125
	6. Concentrated Axial Force on the End of a Rectangular HSS with a Cap Plate	125
K2.	HSS-to-HSS Truss Connections	126
	1. Definitions of Parameters	127
	2. Criteria for Round HSS	128
	2a. Limits of Applicability	128
	2b. Branches with Axial Loads in T-, Y- and Cross-Connections	129
	2c. Branches with Axial Loads in K-Connections	129
	3. Criteria for Rectangular HSS	130
	3a. Limits of Applicability	131
	3b. Branches with Axial Loads in T-, Y- and Cross-Connections	132
	3c. Branches with Axial Loads in Gapped K-Connections	133
	3d. Branches with Axial Loads in Overlapped K-Connections	134
	3e. Welds to Branches	135

K3.	HSS-to-HSS Moment Connections	135
1.	Definitions of Parameters	136
2.	Criteria for Round HSS	136
2a.	Limits of Applicability	137
2b.	Branches with In-Plane Bending Moments in T-, Y- and Cross-Connections	137
2c.	Branches with Out-of-Plane Bending Moments in T-, Y- and Cross-Connections	138
2d.	Branches with Combined Bending Moment and Axial Force in T-, Y- and Cross-Connections	138
3.	Criteria for Rectangular HSS	139
3a.	Limits of Applicability	140
3b.	Branches with In-Plane Bending Moments in T- and Cross-Connections	140
3c.	Branches with Out-of-Plane Bending Moments in T- and Cross-Connections	141
3d.	Branches with Combined Bending Moment and Axial Force in T- and Cross-Connections	142
L.	DESIGN FOR SERVICEABILITY	143
L1.	General Provisions	143
L2.	Camber	143
L3.	Deflections	144
L4.	Drift	144
L5.	Vibration	144
L6.	Wind-Induced Motion	144
L7.	Expansion and Contraction	144
L8.	Connection Slip	144
M.	FABRICATION, ERECTION AND QUALITY CONTROL	145
M1.	Shop and Erection Drawings	145
M2.	Fabrication	145
1.	Cambering, Curving and Straightening	145
2.	Thermal Cutting	145
3.	Planing of Edges	146
4.	Welded Construction	146
5.	Bolted Construction	146
6.	Compression Joints	147
7.	Dimensional Tolerances	147
8.	Finish of Column Bases	147
9.	Holes for Anchor Rods	147
10.	Drain Holes	147
11.	Requirements for Galvanized Members	148
M3.	Shop Painting	148
1.	General Requirements	148

2.	Inaccessible Surfaces	148
3.	Contact Surfaces	148
4.	Finished Surfaces	148
5.	Surfaces Adjacent to Field Welds	148
M4.	Erection	148
1.	Alignment of Column Bases	148
2.	Bracing	148
3.	Alignment	149
4.	Fit of Column Compression Joints and Base Plates	149
5.	Field Welding	149
6.	Field Painting	149
7.	Field Connections	149
M5.	Quality Control	149
1.	Cooperation	150
2.	Rejections	150
3.	Inspection of Welding	150
4.	Inspection of Slip-Critical High-Strength Bolted Connections	150
5.	Identification of Steel	150
APPENDIX 1. INELASTIC ANALYSIS AND DESIGN		151
1.1.	General Provisions	151
1.2.	Materials	151
1.3.	Moment Redistribution	151
1.4.	Local Buckling	152
1.5.	Stability and Second-Order Effects	153
1.	Braced Frames	153
2.	Moment Frames	153
1.6.	Columns and Other Compression Members	153
1.7.	Beams and Other Flexural Members	154
1.8.	Members under Combined Forces	154
1.9.	Connections	154
APPENDIX 2. DESIGN FOR PONDING		155
2.1.	Simplified Design for Ponding	155
2.2.	Improved Design for Ponding	156
APPENDIX 3. DESIGN FOR FATIGUE		159
3.1.	General	159
3.2.	Calculation of Maximum Stresses and Stress Ranges	160
3.3.	Design Stress Range	160
3.4.	Bolts and Threaded Parts	162
3.5.	Special Fabrication and Erection Requirements	163
APPENDIX 4. STRUCTURAL DESIGN FOR FIRE CONDITIONS		178
4.1.	General Provisions	178
4.1.1.	Performance Objective	179

4.1.2.	Design by Engineering Analysis	180
4.1.3.	Design by Qualification Testing	180
4.1.4.	Load Combinations and Required Strength	180
4.2.	Structural Design for Fire Conditions by Analysis	180
4.2.1.	Design-Basis Fire	180
4.2.1.1.	Localized Fire	181
4.2.1.2.	Post-Flashover Compartment Fires	181
4.2.1.3.	Exterior Fires	181
4.2.1.4.	Fire Duration	181
4.2.1.5.	Active Fire Protection Systems	181
4.2.2.	Temperatures in Structural Systems under Fire Conditions	181
4.2.3.	Material Strengths at Elevated Temperatures	182
4.2.3.1.	Thermal Elongation	182
4.2.3.2.	Mechanical Properties at Elevated Temperatures	182
4.2.4.	Structural Design Requirements	183
4.2.4.1.	General Structural Integrity	183
4.2.4.2.	Strength Requirements and Deformation Limits	183
4.2.4.3.	Methods of Analysis	184
4.2.4.3a.	Advanced Methods of Analysis	184
4.2.4.3b.	Simple Methods of Analysis	184
4.2.4.4.	Design Strength	185
4.3.	Design by Qualification Testing	185
4.3.1.	Qualification Standards	185
4.3.2.	Restrained Construction	185
4.3.3.	Unrestrained Construction	186
APPENDIX 5. EVALUATION OF EXISTING STRUCTURES		187
5.1.	General Provisions	187
5.2.	Material Properties	187
1.	Determination of Required Tests	187
2.	Tensile Properties	187
3.	Chemical Composition	188
4.	Base Metal Notch Toughness	188
5.	Weld Metal	188
6.	Bolts and Rivets	188
5.3.	Evaluation by Structural Analysis	188
1.	Dimensional Data	188
2.	Strength Evaluation	189
3.	Serviceability Evaluation	189
5.4.	Evaluation by Load Tests	189
1.	Determination of Load Rating by Testing	189
2.	Serviceability Evaluation	190
5.5.	Evaluation Report	190

APPENDIX 6. STABILITY BRACING FOR COLUMNS AND BEAMS . .	191
6.1. General Provisions	191
6.2. Columns	191
1. Relative Bracing	192
2. Nodal Bracing	192
6.3. Beams	193
1. Lateral Bracing	193
1a. Relative Bracing	193
1b. Nodal Bracing	193
2. Torsional Bracing	194
2a. Nodal Bracing	194
2b. Continuous Torsional Bracing	195
APPENDIX 7. DIRECT ANALYSIS METHOD	196
7.1. General Requirements	196
7.2. Notional Loads	196
7.3. Design-Analysis Constraints	196
COMMENTARY	
INTRODUCTION	199
COMMENTARY GLOSSARY	200
A. GENERAL PROVISIONS	203
A1. Scope	203
A2. Referenced Specifications, Codes and Standards	204
A3. Material	204
1. Structural Steel Materials	204
1a. ASTM Designations	204
1c. Rolled Heavy Shapes	207
2. Steel Castings and Forgings	208
3. Bolts, Washers and Nuts	208
4. Anchor Rods and Threaded Rods	208
5. Filler Metal and Flux for Welding	208
A4. Structural Design Drawings and Specifications	209
B. DESIGN REQUIREMENTS	210
B1. General Provisions	210
B2. Loads and Load Combinations	211
B3. Design Basis	213
1. Required Strength	213
2. Limit States	213
3. Design for Strength Using Load and Resistance Factor Design (LRFD)	214
4. Design for Strength Using Allowable Strength Design (ASD)	216
5. Design for Stability	217
6. Design of Connections	218
7. Design for Serviceability	222

8.	Design for Ponding	222
9.	Design for Fatigue	222
10.	Design for Fire Conditions	222
11.	Design for Corrosion Effects	222
12.	Design Wall Thickness for HSS	223
B4.	Classification of Sections for Local Buckling	223
B5.	Fabrication, Erection and Quality Control	226
B6.	Evaluation of Existing Structures	226
C.	STABILITY ANALYSIS AND DESIGN	227
C1.	Stability Design Requirements	227
1.	General Requirements	227
2.	Member Stability Design Requirements	228
3.	System Stability Design Requirements	229
3a.	Braced-Frame and Shear-Wall Systems	229
3b.	Moment-Frame Systems	229
3c.	Gravity Framing Systems	229
3d.	Combined Systems	229
C2.	Calculation of Required Strengths	230
1.	Methods of Second-Order Analysis	230
1a.	General Second-Order Elastic Analysis	231
1b.	Second-Order Analysis by Amplified First-Order Elastic Analysis	232
2.	Design Requirements	236
2a.	Design by Second-Order Analysis	237
2b.	Design by First-Order Analysis	238
D.	DESIGN OF MEMBERS FOR TENSION	249
D1.	Slenderness Limitations	249
D2.	Tensile Strength	249
D3.	Area Determination	250
1.	Gross Area	250
2.	Net Area	250
3.	Effective Net Area	250
D4.	Built-Up Members	252
D5.	Pin-Connected Members	253
1.	Tensile Strength	254
2.	Dimensional Requirements	254
D6.	Eyebars	254
1.	Tensile Strength	255
2.	Dimensional Requirements	255
E.	DESIGN OF MEMBERS FOR COMPRESSION	256
E1.	General Provisions	256
E2.	Slenderness Limitations and Effective Length	258

E3.	Compressive Strength for Flexural Buckling of Members without Slender Elements	258
E4.	Compressive Strength for Torsional and Flexural-Torsional Buckling of Members without Slender Elements	260
E5.	Single-Angle Compression Members	261
E6.	Built-Up Members	262
	1. Compressive Strength	263
	2. Dimensional Requirements	263
E7.	Members with Slender Elements	263
	1. Slender Unstiffened Elements, Q_s	264
	2. Slender Stiffened Elements, Q_a	266
F.	DESIGN OF MEMBERS FOR FLEXURE	268
F1.	General Provisions	268
F2.	Doubly Symmetric Compact I-Shaped Members and Channels Bent About Their Major Axis	271
F3.	Doubly Symmetric I-Shaped Members with Compact Webs and Noncompact or Slender Flanges Bent about Their Major Axis	272
F4.	Other I-Shaped Members with Compact or Noncompact Webs Bent about Their Major Axis	273
F5.	Doubly Symmetric and Singly Symmetric I-Shaped Members with Slender Webs Bent about Their Major Axis	275
F6.	I-Shaped Members and Channels Bent about Their Minor Axis	275
F7.	Square and Rectangular HSS and Box-Shaped Members	275
F8.	Round HSS	277
F9.	Tees and Double Angles Loaded in the Plane of Symmetry	277
F10.	Single Angles	279
	1. Yielding	279
	2. Lateral-Torsional Buckling	279
	3. Leg Local Buckling	283
F11.	Rectangular Bars and Rounds	283
F12.	Unsymmetrical Shapes	283
F13.	Proportions of Beams and Girders	284
	1. Hole Reductions	284
	2. Proportioning Limits for I-Shaped Members	285
G.	DESIGN OF MEMBERS FOR SHEAR	286
G1.	General Provisions	286
G2.	Members with Unstiffened or Stiffened Webs	286
	1. Nominal Shear Strength	286
	2. Transverse Stiffeners	288
G3.	Tension Field Action	288
	1. Limits on the Use of Tension Field Action	288
	2. Nominal Shear Strength with Tension Field Action	289
	3. Transverse Stiffeners	289

G4.	Single Angles	289
G5.	Rectangular HSS and Box Members	290
G6.	Round HSS	290
G7.	Weak Axis Shear in Singly and Doubly Symmetric Shapes	290
G8.	Beams and Girders with Web Openings	291
H.	DESIGN OF MEMBERS FOR COMBINED FORCES AND TORSION	292
H1.	Doubly and Singly Symmetric Members Subject to Flexure and Axial Force	292
1.	Doubly and Singly Symmetric Members in Flexure and Compression	292
2.	Doubly and Singly Symmetric Members in Flexure and Tension	295
3.	Doubly Symmetric Members in Single Axis Flexure and Compression	296
H2.	Unsymmetric and Other Members Subject to Flexure and Axial Force	297
H3.	Members Under Torsion and Combined Torsion, Flexure, Shear and/or Axial Force	298
1.	Torsional Strength of Round and Rectangular HSS	298
2.	HSS Subject to Combined Torsion, Shear, Flexure and Axial Force	300
3.	Strength of Non-HSS Members under Torsion and Combined Stress	300
I.	DESIGN OF COMPOSITE MEMBERS	301
I1.	General Provisions	301
1.	Nominal Strength of Composite Sections	302
1a.	Plastic Stress Distribution Method	302
1b.	Strain-Compatibility Approach	303
2.	Material Limitations	303
3.	Shear Connectors	303
I2.	Axial Members	304
1.	Encased Composite Columns	304
1a.	Limitations	304
1b.	Compressive Strength	304
1c.	Tensile Strength	305
1d.	Shear Strength	305
1e.	Load Transfer	305
2.	Filled Composite Columns	306
2a.	Limitations	306
2b.	Compressive Strength	306
2c.	Tensile Strength	306
2d.	Shear Strength	306
2e.	Load Transfer	306
2f.	Detailing Requirements	308

I3.	Flexural Members	308
1.	General	308
1a.	Effective Width	311
1b.	Shear Strength	312
1c.	Strength during Construction	312
2.	Strength of Composite Beams with Shear Connectors	313
2a.	Positive Flexural Strength	313
2b.	Negative Flexural Strength	313
2c.	Strength of Composite Beams with Formed Steel Deck	313
2d.	Shear Connectors	314
3.	Flexural Strength of Concrete-Encased and Filled Members	319
I4.	Combined Axial Force and Flexure	319
I5.	Special Cases	323
J.	DESIGN OF CONNECTIONS	324
J1.	General Provisions	324
1.	Design Basis	324
2.	Simple Connections	324
3.	Moment Connections	325
4.	Compression Members with Bearing Joints	325
5.	Splices in Heavy Sections	325
6.	Beam Copes and Weld Access Holes	327
7.	Placement of Welds and Bolts	328
8.	Bolts in Combination with Welds	329
9.	High-Strength Bolts in Combination with Rivets	330
10.	Limitations on Bolted and Welded Connections	330
J2.	Welds	330
1.	Groove Welds	330
1a.	Effective Area	330
1b.	Limitations	330
2.	Fillet Welds	330
2a.	Effective Area	330
2b.	Limitations	331
3.	Plug and Slot Welds	337
3a.	Effective Area	337
3b.	Limitations	337
4.	Strength	337
5.	Combination of Welds	341
6.	Filler Metal Requirements	342
7.	Mixed Weld Metal	342
J3.	Bolts and Threaded Parts	342
1.	High-Strength Bolts	342
2.	Size and Use of Holes	343
3.	Minimum Spacing	343
4.	Minimum Edge Distance	343

5.	Maximum Spacing and Edge Distance	343
6.	Tension and Shear Strength of Bolts and Threaded Parts	344
7.	Combined Tension and Shear in Bearing-Type Connections	345
8.	High-Strength Bolts in Slip-Critical Connections	346
9.	Combined Tension and Shear in Slip-Critical Connections	349
10.	Bearing Strength at Bolt Holes	349
12.	Tension Fasteners	350
J4.	Affected Elements of Members and Connecting Elements	350
1.	Strength of Elements in Tension	350
2.	Strength of Elements in Shear	351
3.	Block Shear Strength	351
4.	Strength of Elements in Compression	353
J5.	Fillers	353
J6.	Splices	353
J7.	Bearing Strength	353
J8.	Column Bases and Bearing on Concrete	353
J9.	Anchor Rods and Embedments	353
J10.	Flanges and Webs with Concentrated Forces	354
1.	Flange Local Bending	356
2.	Web Local Yielding	356
3.	Web Crippling	357
4.	Web Sidesway Buckling	357
5.	Web Compression Buckling	358
6.	Web Panel-Zone Shear	359
7.	Unframed Ends of Beams and Girders	361
8.	Additional Stiffener Requirements for Concentrated Forces	361
9.	Additional Doubler Plate Requirements for Concentrated Forces	364
K.	DESIGN OF HSS AND BOX MEMBER CONNECTIONS	365
K1.	Concentrated Forces on HSS	365
1.	Definitions of Parameters	365
2.	Limits of Applicability	365
3.	Concentrated Force Distributed Transversely	366
4.	Concentrated Force Distributed Longitudinally at the Center of the HSS Diameter or Width, and Acting Perpendicular to the HSS Axis	367
5.	Concentrated Force Distributed Longitudinally at the Center of the HSS Width, and Acting Parallel to the HSS Axis	367
6.	Concentrated Axial Force on the End of a Rectangular HSS with a Cap Plate	367
K2.	HSS-to-HSS Truss Connections	369
1.	Definitions of Parameters	372
2.	Criteria for Round HSS	372
3.	Criteria for Rectangular HSS	374
K3.	HSS-to-HSS Moment Connections	379

L. DESIGN FOR SERVICEABILITY	381
L1. General Provisions	381
L2. Camber	382
L3. Deflections	382
L4. Drift	383
L5. Vibration	385
L6. Wind-Induced Motion	385
L7. Expansion and Contraction	386
L8. Connection Slip	386
M. FABRICATION, ERECTION AND QUALITY CONTROL	388
M1. Shop and Erection Drawings	388
M2. Fabrication	388
1. Cambering, Curving and Straightening	388
2. Thermal Cutting	388
4. Welded Construction	389
5. Bolted Construction	389
10. Drain Holes	389
11. Requirements for Galvanized Members	390
M3. Shop Painting	391
1. General Requirements	391
3. Contact Surfaces	391
5. Surfaces Adjacent to Field Welds	391
M4. Erection	391
2. Bracing	391
4. Fit of Column Compression Joints and Base Plates	391
5. Field Welding	392
M5. Quality Control	392
1. Identification of Steel	392
APPENDIX 1. INELASTIC ANALYSIS AND DESIGN	393
1.1. General Provisions	393
1.2. Materials	393
1.3. Moment Redistribution	393
1.4. Local Buckling	393
1.5. Stability and Second-Order Effects	394
1. Braced Frames	395
2. Moment Frames	395
1.6. Columns and Other Compression Members	395
1.7. Beams and Other Flexural Members	395
1.8. Members Under Combined Forces	396
1.9. Connections	396
APPENDIX 2. DESIGN FOR PONDING	397

APPENDIX 3. DESIGN FOR FATIGUE	400
3.1. General	400
3.2. Calculation of Maximum Stresses and Stress Ranges	400
3.3. Design Stress Range	401
3.4. Bolts and Threaded Parts	402
3.5. Special Fabrication and Erection Requirements	403
APPENDIX 4. STRUCTURAL DESIGN FOR FIRE CONDITIONS	405
4.1. General Provisions	405
4.1.1. Performance Objective	405
4.1.4. Load Combinations and Required Strength	406
4.2. Structural Design for Fire Conditions by Analysis	407
4.2.1. Design-Basis Fire	407
4.2.1.1. Localized Fire	407
4.2.1.2. Post-Flashover Compartment Fires	407
4.2.1.3. Exterior Fires	408
4.2.1.4. Fire Duration	408
4.2.1.5. Active Fire Protection Systems	408
4.2.2. Temperatures in Structural Systems under Fire Conditions	408
4.2.3. Material Strengths at Elevated Temperatures	412
4.2.4. Structural Design Requirements	412
4.2.4.1. General Structural Integrity	412
4.2.4.2. Strength Requirements and Deformation Limits	413
4.2.4.3. Methods of Analysis	413
4.2.4.3a. Advanced Methods of Analysis	413
4.2.4.3b. Simple Methods of Analysis	413
4.2.4.4. Design Strength	413
4.3. Design by Qualification Testing	413
APPENDIX 5. EVALUATION OF EXISTING STRUCTURES	417
5.1. General Provisions	417
5.2. Material Properties	417
1. Determination of Required Tests	417
2. Tensile Properties	417
4. Base Metal Notch Toughness	418
5. Weld Metal	418
6. Bolts and Rivets	418
5.3. Evaluation by Structural Analysis	418
2. Strength Evaluation	418
5.4. Evaluation by Load Tests	419
1. Determination of Live Load Rating by Testing	419
2. Serviceability Evaluation	419
5.5. Evaluation Report	420

APPENDIX 6. STABILITY BRACING FOR COLUMNS AND BEAMS . .	421
6.1. General Provisions	421
6.2. Columns	424
6.3. Beams	425
1. Lateral Bracing	425
2. Torsional Bracing	426
APPENDIX 7. DIRECT ANALYSIS METHOD	429
7.1. General Requirements	429
7.2. Notional Loads	433
7.3. Design-Analysis Constraints	434
REFERENCES	439

SYMBOLS

The section or table number in the right-hand column refers to where the symbol is first used.

<u>Symbol</u>	<u>Definition</u>	<u>Section</u>
A	Column cross-sectional area, in. ² (mm ²)	J10.6
A	Total cross-sectional area of member, in. ² (mm ²)	E7.2
A_B	Loaded area of concrete, in. ² (mm ²)	I2.1
A_{BM}	Cross-sectional area of the base metal, in. ² (mm ²)	J2.4
A_b	Nominal unthreaded body area of bolt or threaded part, in. ² (mm ²)	J3.6
A_{bi}	Cross-sectional area of the overlapping branch, in. ² (mm ²)	K2.3
A_{bj}	Cross-sectional area of the overlapped branch, in. ² (mm ²)	K2.3
A_c	Area of concrete, in. ² (mm ²)	I2.1
A_c	Area of concrete slab within effective width, in. ² (mm ²)	I3.2
A_D	Area of an upset rod based on the major thread diameter, in. ² (mm ²)	Table J3.2
A_e	Effective net area, in. ² (mm ²)	D2
A_{eff}	Summation of the effective areas of the cross section based on the reduced effective width, b_e , in. ² (mm ²)	E7.2
A_{fc}	Area of compression flange	G3.1
A_{fg}	Gross tension flange area, in. ² (mm ²)	F13.1
A_{fn}	Net tension flange area, in. ² (mm ²)	F13.1
A_{ft}	Area of tension flange, in. ² (mm ²)	G3.1
A_g	Gross area of member, in. ² (mm ²)	B3.13
A_g	Gross area of section based on design wall thickness, in. ² (mm ²)	G6
A_g	Gross area of composite member, in. ² (mm ²)	I2.1
A_g	Chord gross area, in. ² (mm ²)	K2.2
A_{gv}	Gross area subject to shear, in. ² (mm ²)	J4.3
A_n	Net area of member, in. ² (mm ²)	B3.13
A_{nt}	Net area subject to tension, in. ² (mm ²)	J4.3
A_{nv}	Net area subject to shear, in. ² (mm ²)	J4.2
A_{pb}	Projected bearing area, in. ² (mm ²)	J7
A_r	Area of adequately developed longitudinal reinforcing steel within the effective width of the concrete slab, in. ² (mm ²)	I3.2
A_s	Area of steel cross section, in. ² (mm ²)	I2.1
A_{sc}	Cross-sectional area of stud shear connector, in. ² (mm ²)	I2.1
A_{sf}	Shear area on the failure path, in. ² (mm ²)	D5.1
A_{sr}	Area of continuous reinforcing bars, in. ² (mm ²)	I2.1
A_{st}	Stiffener area, in. ² (mm ²)	G3.3
A_t	Net tensile area, in. ² (mm ²)	App. 3.4
A_w	Web area, the overall depth times the web thickness, dt_w , in. ² (mm ²)	G2.1

A_w	Effective area of the weld, in. ² (mm ²)	J2.4
A_{wi}	Effective area of weld throat of any i th weld element, in. ² (mm ²)	J2.4
A_1	Area of steel concentrically bearing on a concrete support, in. ² (mm ²)	J8
A_2	Maximum area of the portion of the supporting surface that is geometrically similar to and concentric with the loaded area, in. ² (mm ²)	J8
B	Overall width of rectangular HSS member, measured 90 degrees to the plane of the connection, in. (mm)	Table D3.1
B	Overall width of rectangular HSS main member, measured 90 degrees to the plane of the connection, in. (mm)	K3.1
B	Factor for lateral-torsional buckling in tees and double angles	F9.2
B_b	Overall width of rectangular HSS branch member, measured 90 degrees to the plane of the connection, in. (mm)	K3.1
B_{bi}	Overall branch width of the overlapping branch	K2.3
B_{bj}	Overall branch width of the overlapped branch	K2.3
B_p	Width of plate, measure 90 degrees to the plane of the connection, in. (mm)	K1.1
B_p	Width of plate, transverse to the axis of the main member, in. (mm)	K2.3
B_1, B_2	Factors used in determining M_u for combined bending and axial forces when first-order analysis is employed	C2.1
C	HSS torsional constant	H3.1
C_b	Lateral-torsional buckling modification factor for nonuniform moment diagrams when both ends of the unsupported segment are braced	F1
C_d	Coefficient relating relative brace stiffness and curvature	App. 6.3.1
C_f	Constant based on stress category, given in Table A-3.1	App. 3.3
C_m	Coefficient assuming no lateral translation of the frame	C2.1
C_p	Ponding flexibility coefficient for primary member in a flat roof	App. 2.1
C_r	Coefficient for web sidesway buckling	J10.4
C_s	Ponding flexibility coefficient for secondary member in a flat roof	App. 2.1
C_v	Web shear coefficient	G2.1
C_w	Warping constant, in. ⁶ (mm ⁶)	E4
D	Nominal dead load	App. 2.2
D	Outside diameter of round HSS member, in. (mm)	Table B4.1
D	Outside diameter, in. (mm)	E7.2
D	Outside diameter of round HSS main member, in. (mm)	K2.1
D	Chord diameter, in. (mm)	K2.2
D_b	Outside diameter of round HSS branch member, in. (mm)	K2.1
D_s	Factor used in Equation G3-3, dependent on the type of transverse stiffeners used in a plate girder	G3.3
D_u	In slip-critical connections, a multiplier that reflects the ratio of the mean installed bolt pretension to the specified minimum bolt pretension	J3.8
E	Modulus of elasticity of steel = 29,000 ksi (200 000 MPa)	Table B4.1
E_c	Modulus of elasticity of concrete = $w_c^{1.5} \sqrt{f'_c}$, ksi (0.043 $w_c^{1.5} \sqrt{f'_c}$, MPa)	I2.1

E_{cm}	Modulus of elasticity of concrete at elevated temperature, ksi (MPa)	App. 4.2.3
EI_{eff}	Effective stiffness of composite section, kip-in. ² (N-mm ²)	I2.1
E_m	Modulus of elasticity of steel at elevated temperature, ksi (MPa)	App. 4.2.3
E_s	Modulus of elasticity of steel = 29,000 ksi (200 000 MPa)	I2.1
F_a	Available axial stress at the point of consideration, ksi (MPa)	H2
F_{BM}	Nominal strength of the base metal per unit area, ksi (MPa)	J2.4
F_{bw}	Available flexural stress at the point of consideration about the major axis, ksi (MPa)	H2
F_{bz}	Available flexural stress at the point of consideration about the minor axis, ksi (MPa)	H2
F_c	Available stress, ksi (MPa)	K2.2
F_{cr}	Critical stress, ksi (MPa)	E3
F_{cr}	Buckling stress for the section as determined by analysis, ksi (MPa)	F12.2
F_{cry}	Critical stress about the minor axis, ksi (MPa)	E4
F_{crz}	Critical torsional buckling stress, ksi (MPa)	E4
F_e	Elastic critical buckling stress, ksi (MPa)	C1.3
F_{ex}	Elastic flexural buckling stress about the major axis, ksi (MPa)	E4
F_{EXX}	Electrode classification number, ksi (MPa)	J2.4
F_{ey}	Elastic flexural buckling stress about the minor axis, ksi (MPa)	E4
F_{ez}	Elastic torsional buckling stress, ksi (MPa)	E4
F_L	A calculated stress used in the calculation of nominal flexural strength, ksi (MPa)	Table B4.1
F_n	Nominal torsional strength	H3.3
F_n	Nominal tensile stress F_{nt} , or shear stress, F_{nv} , from Table J3.2, ksi (MPa)	J3.6
F_{nt}	Nominal tensile stress from Table J3.2, ksi (MPa)	J3.7
F'_{nt}	Nominal tensile stress modified to include the effects of shearing stress, ksi (MPa)	J3.7
F_{nv}	Nominal shear stress from Table J3.2, ksi (MPa)	J3.7
F_{SR}	Design stress range, ksi (MPa)	App. 3.3
F_{TH}	Threshold fatigue stress range, maximum stress range for indefinite design life from Table A-3.1, ksi (MPa)	App. 3.1
F_u	Specified minimum tensile strength of the type of steel being used, ksi (MPa)	D2
F_u	Specified minimum tensile strength of a stud shear connector, ksi (MPa)	I2.1
F_u	Specified minimum tensile strength of the connected material, ksi (MPa)	J3.10
F_u	Specified minimum tensile strength of HSS material, ksi (MPa)	K1.1
F_{um}	Specified minimum tensile strength of the type of steel being used at elevated temperature, ksi (MPa)	App. 4.2
F_w	Nominal strength of the weld metal per unit area, ksi (MPa)	J2.4
F_{wi}	Nominal stress in any i th weld element, ksi (MPa)	J2.4

F_{wix}	x component of stress F_{wi} , ksi (MPa)	J2.4
F_{wiy}	y component of stress F_{wi} , ksi (MPa)	J2.4
F_y	Specified minimum yield stress of the type of steel being used, ksi (MPa). As used in this Specification, “yield stress” denotes either the specified minimum yield point (for those steels that have a yield point) or specified yield strength (for those steels that do not have a yield point)	Table B4.1
F_y	Specified minimum yield stress of the compression flange, ksi (MPa)	App. 1.3
F_y	Specified minimum yield stress of the column web, ksi (MPa)	J10.6
F_y	Specified minimum yield stress of HSS member material, ksi (MPa)	K1.1
F_y	Specified minimum yield stress of HSS main member material, ksi (MPa)	K2.1
F_{yb}	Specified minimum yield stress of HSS branch member material, ksi (MPa)	K2.1
F_{ybi}	Specified minimum yield stress of the overlapping branch material, ksi (MPa)	K2.3
F_{ybj}	Specified minimum yield stress of the overlapped branch material, ksi (MPa)	K2.3
F_{yf}	Specified minimum yield stress of the flange, ksi (MPa)	J10.1
F_{ym}	Specified minimum yield stress of the type of steel being used at elevated temperature, ksi (MPa)	App. 4.2
F_{yp}	Specified minimum yield stress of plate, ksi (MPa)	K1.1
F_{yr}	Specified minimum yield stress of reinforcing bars, ksi (MPa)	I2.1
F_{yst}	Specified minimum yield stress of the stiffener material, ksi (MPa)	G3.3
F_{yw}	Specified minimum yield stress of the web, ksi (MPa)	J10.2
G	Shear modulus of elasticity of steel = 11,200 ksi (77 200 MPa)	E4
ΣH	Story shear produced by the lateral forces used to compute Δ_H , kips (N)	C2.1
H	Overall height of rectangular HSS member, measured in the plane of the connection, in. (mm)	Table D3.1
H	Overall height of rectangular HSS main member, measured in the plane of the connection, in. (mm)	K2.1
H	Flexural constant	E4
H_b	Overall height of rectangular HSS branch member, measured in the plane of the connection, in. (mm)	K2.1
H_{bi}	Overall depth of the overlapping branch	K2.3
I	Moment of inertia in the place of bending, in. ⁴ (mm ⁴)	C2.1
I	Moment of inertia about the axis of bending, in. ⁴ (mm ⁴)	App. 7.3
I_c	Moment of inertia of the concrete section, in. ⁴ (mm ⁴)	I2.1
I_d	Moment of inertia of the steel deck supported on secondary members, in. ⁴ (mm ⁴)	App. 2.1
I_p	Moment of inertia of primary members, in. ⁴ (mm ⁴)	App. 2.1
I_s	Moment of inertia of secondary members, in. ⁴ (mm ⁴)	App. 2.1

I_s	Moment of inertia of steel shape, in. ⁴ (mm ⁴)	I2.1
I_{sr}	Moment of inertia of reinforcing bars, in. ⁴ (mm ⁴)	I2.1
I_x, I_y	Moment of inertia about the principal axes, in. ⁴ (mm ⁴)	E4
I_y	Out-of-plane moment of inertia, in. ⁴ (mm ⁴)	App. 6.2
I_z	Minor principal axis moment of inertia, in. ⁴ (mm ⁴)	F10.2
I_{yc}	Moment of inertia about y-axis referred to the compression flange, or if reverse curvature bending referred to smaller flange, in. ⁴ (mm ⁴)	F1
J	Torsional constant, in. ⁴ (mm ⁴)	E4
K	Effective length factor determined in accordance with Chapter C	C1.2
K_z	Effective length factor for torsional buckling	E4
K_1	Effective length factor in the plane of bending, calculated based on the assumption of no lateral translation set equal to 1.0 unless analysis indicates that a smaller value may be used	C2.1
K_2	Effective length factor in the plane of bending, calculated based on a sidesway buckling analysis	C2.1
L	Story height, in. (mm)	C2.1
L	Length of the member, in. (mm)	H3
L	Actual length of end-loaded weld, in. (mm)	J2.2
L	Nominal occupancy live load	App. 4.1.4
L	Laterally unbraced length of a member, in. (mm)	E2
L	Span length, in. (mm)	App. 6.2
L	Length of member between work points at truss chord centerlines, in. (mm)	E5
L_b	Length between points that are either braced against lateral displacement of compression flange or braced against twist of the cross section, in. (mm)	F2
L_b	Distance between braces, in. (mm)	App. 6.2
L_c	Length of channel shear connector, in. (mm)	I3.2
L_c	Clear distance, in the direction of the force, between the edge of the hole and the edge of the adjacent hole or edge of the material, in. (mm)	J3.10
L_e	Total effective weld length of groove and fillet welds to rectangular HSS, in. (mm)	K2.3
L_p	Limiting laterally unbraced length for the limit state of yielding in. (mm)	F2.2
L_p	Column spacing in direction of girder, ft (m)	App. 2
L_{pd}	Limiting laterally unbraced length for plastic analysis, in. (mm)	App. 1.7
L_q	Maximum unbraced length for M_r (the required flexural strength), in. (mm)	App. 6.2
L_r	Limiting laterally unbraced length for the limit state of inelastic lateral-torsional buckling, in. (mm)	F2.2
L_s	Column spacing perpendicular to direction of girder, ft (m)	App. 2.1
L_v	Distance from maximum to zero shear force, in. (mm)	G6

M_A	Absolute value of moment at quarter point of the unbraced segment, kip-in. (N-mm)	F1
M_a	Required flexural strength in chord, using ASD load combinations, kip-in. (N-mm)	K2.2
M_B	Absolute value of moment at centerline of the unbraced segment, kip-in. (N-mm)	F1
M_{br}	Required bracing moment, kip-in. (N-mm)	App. 6.2
M_C	Absolute value of moment at three-quarter point of the unbraced segment, kip-in. (N-mm)	F1
$M_{c(x,y)}$	Available flexural strength determined in accordance with Chapter F, kip-in. (N-mm)	H1.1
M_{cx}	Available flexural-torsional strength for strong axis flexure determined in accordance with Chapter F, kip-in. (N-mm)	H1.3
M_e	Elastic lateral-torsional buckling moment, kip-in. (N-mm)	F10.2
M_{lt}	First-order moment under LRFD or ASD load combinations caused by lateral translation of the frame only, kip-in. (N-mm)	C2.1
M_{max}	Absolute value of maximum moment in the unbraced segment, kip-in. (N-mm)	F1
M_n	Nominal flexural strength, kip-in. (N-mm)	F1
M_{nt}	First-order moment using LRFD or ASD load combinations assuming there is no lateral translation of the frame, kip-in. (N-mm)	C2.1
M_p	Plastic bending moment, kip-in. (N-mm)	Table B4.1
M_r	Required second-order flexural strength under LRFD or ASD load combinations, kip-in. (N-mm)	C2.1
M_r	Required flexural strength using LRFD or ASD load combinations, kip-in. (N-mm)	H1
M_r	Required flexural strength in chord, kip-in. (N-mm)	K2.2
M_{r-ip}	Required in-plane flexural strength in branch, kip-in. (N-mm)	K3.2
M_{r-op}	Required out-of-plane flexural strength in branch, kip-in. (N-mm)	K3.2
M_u	Required flexural strength in chord, using LRFD load combinations, kip-in. (N-mm)	K2.2
M_y	Yield moment about the axis of bending, kip-in. (N-mm)	Table B4.1
M_1	Smaller moment, calculated from a first-order analysis, at the ends of that portion of the member unbraced in the plane of bending under consideration, kip-in. (N-mm)	C2.1
M_2	Larger moment, calculated from a first-order analysis, at the ends of that portion of the member unbraced in the plane of bending under consideration, kip-in. (N-mm)	C2.1
N	Length of bearing (not less than k for end beam reactions), in. (mm)	J10.2
N	Bearing length of the load, measured parallel to the axis of the HSS member, (or measured across the width of the HSS in the case of the loaded cap plates), in. (mm)	K1.1
N	Number of stress range fluctuations in design life	App. 3.3
N_b	Number of bolts carrying the applied tension	J3.9

N_i	Additional lateral load	C2.2
N_i	Notional lateral load applied at level i , kips (N)	App. 7.3
N_s	Number of slip planes	J3.8
O_v	Overlap connection coefficient	K2.2
P	Pitch, in. per thread (mm per thread)	App. 3.4
P_{br}	Required brace strength, kips (N)	App. 6.2
P_c	Available axial compressive strength, kips (N)	H1.1
P_c	Available tensile strength, kips (N)	H1.2
P_{co}	Available compressive strength out of the plane of bending, kip (N)	H1.3
P_{e1}, P_{e2}	Elastic critical buckling load for braced and unbraced frame, respectively, kips (N)	C2.1
P_{eL}	Euler buckling load, evaluated in the plane of bending, kips (N)	App. 7.3
$P_{l(t,c)}$	First-order axial force using LRFD or ASD load combinations as a result of lateral translation of the frame only (tension or compression), kips (N)	C2.1
$P_{n(t,c)}$	First-order axial force using LRFD or ASD load combinations, assuming there is no lateral translation of the frame (tension or compression), kips (N)	C2.1
P_n	Nominal axial strength, kips (N)	D2
P_o	Nominal axial compressive strength without consideration of length effects, kips (N)	I2.1
P_p	Nominal bearing strength of concrete, kips (N)	I2.1
P_r	Required second-order axial strength using LRFD or ASD load combinations, kips (N)	C2.1
P_r	Required axial compressive strength using LRFD or ASD load combinations, kips (N)	C2.2
P_r	Required tensile strength using LRFD or ASD load combinations, kips (N)	H1.2
P_r	Required strength, kips (N)	J10.6
P_r	Required axial strength in branch, kips (N)	K3.2d
P_r	Required axial strength in chord, kips (N)	K2.2
P_u	Required axial strength in compression, kips (N)	App. 1.4
P_y	Member yield strength, kips (N)	C2.2
Q	Full reduction factor for slender compression elements	E7
Q_a	Reduction factor for slender stiffened compression elements	E7.2
Q_f	Chord-stress interaction parameter	K2.2
Q_n	Nominal strength of one stud shear connector, kips (N)	I2.1
Q_s	Reduction factor for slender unstiffened compression elements	E7.1
R	Nominal load due to rainwater or snow, exclusive of the ponding contribution, ksi (MPa)	App. 2.2
R	Seismic response modification coefficient	A1.1
R_a	Required strength (ASD)	B3.4
R_{FIL}	Reduction factor for joints using a pair of transverse fillet welds only	App. 3.3

R_g	Coefficient to account for group effect	I3.2
R_m	Factor in Equation C2-6b dependent on type of system	C2.1
R_m	Cross-section monosymmetry parameter	F1
R_n	Nominal strength, specified in Chapters B through K	B3.3
R_n	Nominal slip resistance, kips (N)	J3.8
R_p	Position effect factor for shear studs	I3.2
R_{pc}	Web plastification factor	F4.1
R_{PJP}	Reduction factor for reinforced or nonreinforced transverse partial-joint-penetration (PJP) groove welds	App. 3.3
R_{pt}	Web plastification factor corresponding to the tension flange yielding limit state	F4.4
R_u	Required strength (LRFD)	B3.3
R_{wl}	Total nominal strength of longitudinally loaded fillet welds, as determined in accordance with Table J2.5	J2.4
R_{wt}	Total nominal strength of transversely loaded fillet welds, as determined in accordance with Table J2.5 without the alternate in Section J2.4 (a)	J2.4
S	Elastic section modulus of round HSS, in. ³ (mm ³)	F8.2
S	Lowest elastic section modulus relative to the axis of bending, in. ³ (mm ³)	F12
S	Spacing of secondary members, ft (m)	App. 2.1
S	Nominal snow load	App. 4.1.4
S	Chord elastic section modulus, in. ³ (mm ³)	K2.2
S_c	Elastic section modulus to the toe in compression relative to the axis of bending, in. ³ (mm ³)	F10.3
S_{eff}	Effective section modulus about major axis, in. ³ (mm ³)	F7.2
S_{xt}, S_{xc}	Elastic section modulus referred to tension and compression flanges, respectively, in. ³ (mm ³)	Table B4.1
S_x, S_y	Elastic section modulus taken about the principal axes, in. ³ (mm ³)	F2.2, F6
S_y	For channels, taken as the minimum section modulus	F6
T	Nominal forces and deformations due to the design-basis fire defined in Section 4.2.1	App. 4.1.4
T_a	Tension force due to ASD load combinations, kips (kN)	J3.9
T_b	Minimum fastener tension given in Table J3.1 or J3.1M, kips (kN)	J3.8
T_c	Available torsional strength, kip-in. (N-mm)	H3.2
T_n	Nominal torsional strength, kip-in. (N-mm)	H3.1
T_r	Required torsional strength, kip-in. (N-mm)	H3.2
T_u	Tension force due to LRFD load combinations, kips (kN)	J3.9
U	Shear lag factor	D3.3
U	Utilization ratio	K2.2
U_{bs}	Reduction coefficient, used in calculating block shear rupture strength	J4.3
U_p	Stress index	App. 2.2
U_s	Stress index	App. 2.2

V	Required shear force introduced to column, kips (N)	I2.1
V'	Required shear force transferred by shear connectors, kips (N)	I2.1
V_c	Available shear strength, kips (N)	G3.3
V_n	Nominal shear strength, kips (N)	G1
V_r	Required shear strength at the location of the stiffener, kips (N)	G3.3
V_r	Required shear strength using LRFD or ASD load combinations, kips (N)	H3.2
Y_i	Gravity load from the LRFD load combination or 1.6 times the ASD load combination applied at level i , kips (N)	C2.2
Y_t	Hole reduction coefficient, kips (N)	F13.1
Z	Plastic section modulus about the axis of bending, in. ³ (mm ³)	F7.1
Z_b	Branch plastic section modulus about the correct axis of bending, in. ³ (mm ³)	K3.3
$Z_{x,y}$	Plastic section modulus about the principal axes, in. ³ (mm ³)	F2, F6.1
a	Clear distance between transverse stiffeners, in. (mm)	F13.2
a	Distance between connectors in a built-up member, in. (mm)	E6.1
a	Shortest distance from edge of pin hole to edge of member measured parallel to direction of force, in. (mm)	D5.1
a	Half the length of the nonwelded root face in the direction of the thickness of the tension-loaded plate, in. (mm)	App. 3.3
a_w	Ratio of two times the web area in compression due to application of major axis bending moment alone to the area of the compression flange components	F4.2
b	Outside width of leg in compression, in. (mm)	F10.3
b	Full width of longest angle leg, in. (mm)	E7.1
b	Width of unstiffened compression element; for flanges of I-shaped members and tees, the width b is half the full-flange width, b_f ; for legs of angles and flanges of channels and zees, the width b is the full nominal dimension; for plates, the width b is the distance from the free edge to the first row of fasteners or line of welds, or the distance between adjacent lines of fasteners or lines of welds; for rectangular HSS, the width b is the clear distance between the webs less the inside corner radius on each side, in. (mm)	B4.1, B4.2
b	Width of the angle leg resisting the shear force, in. (mm)	G4
b_{cf}	Width of column flange, in. (mm)	J10.6
b_e	Reduced effective width, in. (mm)	E7.2
b_{eff}	Effective edge distance; the distance from the edge of the hole to the edge of the part measured in the direction normal to the applied force, in. (mm)	D5.1
b_{eoi}	Effective width of the branch face welded to the chord	K2.3
b_{eov}	Effective width of the branch face welded to the overlapped brace	K2.3
b_f	Flange width, in. (mm)	B4.1
b_{fc}	Compression flange width, in. (mm)	F4.2
b_{ft}	Width of tension flange, in. (mm)	G3.1

b_l	Longer leg of angle, in. (mm)	E5
b_s	Shorter leg of angle, in. (mm)	E5
b_s	Stiffener width for one-sided stiffeners, in. (mm)	App. 6.2
d	Nominal fastener diameter, in. (mm)	J3.3
d	Full nominal depth of the section, in. (mm)	B4.1
d	Full nominal depth of tee, in. (mm)	E7.1
d	Depth of rectangular bar, in. (mm)	F11.2
d	Full nominal depth of section, in. (mm)	B4.1
d	Full nominal depth of tee, in. (mm)	E7.1
d	Diameter, in. (mm)	J7
d	Pin diameter, in. (mm)	D5.1
d	Roller diameter, in. (mm)	J7
d_b	Beam depth, in. (mm)	J10.6
d_b	Nominal diameter (body or shank diameter), in. (mm)	App. 3.4
d_c	Column depth, in. (mm)	J10.6
e	Eccentricity in a truss connection, positive being away from the branches, in. (mm)	K2.1
e_{mid-ht}	Distance from the edge of stud shank to the steel deck web, measured at mid-height of the deck rib, and in the load bearing direction of the stud (in other words, in the direction of maximum moment for a simply supported beam), in. (mm)	I3.2
f_a	Required axial stress at the point of consideration using LRFD or ASD load combinations, ksi (MPa)	H2
$f_{b(w,z)}$	Required flexural stress at the point of consideration (major axis, minor axis) using LRFD or ASD load combinations, ksi (MPa)	H2
f'_c	Specified minimum compressive strength of concrete, ksi (MPa)	I1.1
f'_{cm}	Specified minimum compressive strength of concrete at elevated temperatures, ksi (MPa)	App. 4.2
f_o	Stress due to D + R (the nominal dead load + the nominal load due to rainwater or snow exclusive of the ponding contribution), ksi (MPa)	App. 2.2
f_v	Required shear strength per unit area, ksi (MPa)	J3.7
g	Transverse center-to-center spacing (gage) between fastener gage lines, in. (mm)	B3.13
g	Gap between toes of branch members in a gapped K-connection, neglecting the welds, in. (mm)	K2.1
h	Clear distance between flanges less the fillet or corner radius for rolled shapes; for built-up sections, the distance between adjacent lines of fasteners or the clear distance between flanges when welds are used; for tees, the overall depth; for rectangular HSS, the clear distance between the flanges less the inside corner radius on each side, in. (mm)	B4.2
h	Distance between centroids of individual components perpendicular to the member axis of buckling, in. (mm)	E6.1

h_c	Twice the distance from the centroid to the following: the inside face of the compression flange less the fillet or corner radius, for rolled shapes; the nearest line of fasteners at the compression flange or the inside faces of the compression flange when welds are used, for built-up sections, in. (mm)	B4.2
h_o	Distance between flange centroids, in. (mm)	F2.2
h_p	Twice the distance from the plastic neutral axis to the nearest line of fasteners at the compression flange or the inside face of the compression flange when welds are used, in. (mm)	B4.2
h_{sc}	Hole factor	J3.8
j	Factor defined by Equation G2-6 for minimum moment of inertia for a transverse stiffener	G2.2
k	Distance from outer face of flange to the web toe of fillet, in. (mm)	J10.2
k	Outside corner radius of the HSS, which is permitted to be taken as 1.5t if unknown, in. (mm)	K1.3
k_c	Coefficient for slender unstiffened elements, in. (mm)	Table B4.1
k_s	Slip-critical combined tension and shear coefficient	J3.9
k_v	Web plate buckling coefficient	G2.1
l	Largest laterally unbraced length along either flange at the point of load, in. (mm)	J10.4
l	Length of bearing, in. (mm)	J7
l	Length of connection in the direction of loading, in. (mm)	Table D3.1
n	Number of nodal braced points within the span	App. 6.2
n	Threads per inch (per mm)	App. 3.4
p	Ratio of element i deformation to its deformation at maximum stress	J2.4
p	Projected length of the overlapping branch on the chord	K2.2
q	Overlap length measured along the connecting face of the chord beneath the two branches	K2.2
r	Governing radius of gyration, in. (mm)	E2
r_{crit}	Distance from instantaneous center of rotation to weld element with minimum Δ_u/r_i ratio, in. (mm)	J2.4
r_i	Minimum radius of gyration of individual component in a built-up member, in. (mm)	E6.1
r_{ib}	Radius of gyration of individual component relative to its centroidal axis parallel to member axis of buckling, in. (mm)	E6.1
\bar{r}_o	Polar radius of gyration about the shear center, in. (mm)	E4
r_t	Radius of gyration of the flange components in flexural compression plus one-third of the web area in compression due to application of major axis bending moment alone	F4.2
r_{ts}	Effective radius of gyration used in the determination of L_r for the lateral-torsional buckling limit state for major axis bending of doubly symmetric compact I-shaped members and channels	F2.2
r_x	Radius of gyration about geometric axis parallel to connected leg, in. (mm)	E5

r_y	Radius of gyration about y-axis, in. (mm)	E4
r_z	Radius of gyration for the minor principal axis, in. (mm)	E5
s	Longitudinal center-to-center spacing (pitch) of any two consecutive holes, in. (mm)	B3.13
t	Thickness of element, in. (mm)	B4.2
t	Wall thickness, in. (mm)	E7.2
t	Angle leg thickness, in. (mm)	F10.2
t	Width of rectangular bar parallel to axis of bending, in. (mm)	F11.2
t	Thickness of connected material, in. (mm)	J3.10
t	Thickness of plate, in. (mm)	D5.1
t	Design wall thickness for HSS equal to 0.93 times the nominal wall thickness for ERW HSS and equal to the nominal wall thickness for SAW HSS, in. (mm)	B3.12
t	Total thickness of fillers, in. (mm)	J5
t	Design wall thickness of HSS main member, in. (mm)	K2.1
t_b	Design wall thickness of HSS branch member, in. (mm)	K2.1
t_{bi}	Thickness of the overlapping branch, in. (mm)	K2.3
t_{bj}	Thickness of the overlapped branch, in. (mm)	K2.3
t_{cf}	Thickness of the column flange, in. (mm)	J10.6
t_f	Thickness of the loaded flange, in. (mm)	J10.1
t_f	Flange thickness of channel shear connector, in. (mm)	I3.2
t_{fc}	Compression flange thickness, in. (mm)	F4.2
t_p	Thickness of plate, in. (mm)	K1.1
t_p	Thickness of tension loaded plate, in. (mm)	App. 3.3
t_p	Thickness of the attached transverse plate, in. (mm)	K2.3
t_s	Web stiffener thickness, in. (mm)	App. 6.2
t_w	Web thickness of channel shear connector, in. (mm)	I3.2
t_w	Beam web thickness, in. (mm)	App. 6.3
t_w	Web thickness, in. (mm)	Table B4.1
t_w	Column web thickness, in. (mm)	J10.6
t_w	Thickness of element, in. (mm)	E7.1
w	Width of cover plate, in. (mm)	F13.3
w	Weld leg size, in. (mm)	J2.2
w	Subscript relating symbol to major principal axis bending	
w	Plate width, in. (mm)	Table D3.1
w	Leg size of the reinforcing or contouring fillet, if any, in the direction of the thickness of the tension-loaded plate, in. (mm)	App. 3.3
w_c	Weight of concrete per unit volume ($90 \leq w_c \leq 155$ lbs/ft ³ or $1500 \leq w_c \leq 2500$ kg/m ³)	I2.1
w_r	Average width of concrete rib or haunch, in. (mm)	I3.2
x	Subscript relating symbol to strong axis	
x_o, y_o	Coordinates of the shear center with respect to the centroid, in. (mm)	E4
\bar{x}	Connection eccentricity, in. (mm)	Table D3.1

y	Subscript relating symbol to weak axis	
z	Subscript relating symbol to minor principal axis bending	
α	Factor used in B2 equation	C2.1
α	Separation ratio for built-up compression members = $\frac{h}{2r_{ib}}$	E6.1
β	Reduction factor given by Equation J2-1	J2.2
β	Width ratio; the ratio of branch diameter to chord diameter for round HSS; the ratio of overall branch width to chord width for rectangular HSS	K2.1
β_T	Brace stiffness requirement excluding web distortion, kip-in./radian (N-mm/radian)	App. 6.2
β_{br}	Required brace stiffness	App. 6.2
β_{eff}	Effective width ratio; the sum of the perimeters of the two branch members in a K-connection divided by eight times the chord width	K2.1
β_{eop}	Effective outside punching parameter	K2.3
β_{sec}	Web distortional stiffness, including the effect of web transverse stiffeners, if any, kip-in./radian (N-mm/radian)	App. 6.2
β_w	Section property for unequal leg angles, positive for short legs in compression and negative for long legs in compression	F10.2
Δ	First-order interstory drift due to the design loads, in. (mm)	C2.2
Δ_H	First-order interstory drift due to lateral forces, in. (mm)	C2.1
Δ_i	Deformation of weld elements at intermediate stress levels, linearly proportioned to the critical deformation based on distance from the instantaneous center of rotation, r_i , in. (mm)	J2.4
Δ_m	Deformation of weld element at maximum stress, in. (mm)	J2.4
Δ_u	Deformation of weld element at ultimate stress (fracture), usually in element furthest from instantaneous center of rotation, in. (mm)	J2.4
γ	Chord slenderness ratio; the ratio of one-half the diameter to the wall thickness for round HSS; the ratio of one-half the width to wall thickness for rectangular HSS	K2.1
ζ	Gap ratio; the ratio of the gap between the branches of a gapped K-connection to the width of the chord for rectangular HSS	K2.1
η	Load length parameter, applicable only to rectangular HSS; the ratio of the length of contact of the branch with the chord in the plane of the connection to the chord width	K2.1
λ	Slenderness parameter	F3
λ_p	Limiting slenderness parameter for compact element	B4
λ_{pf}	Limiting slenderness parameter for compact flange	F3
λ_{pw}	Limiting slenderness parameter for compact web	F4
λ_r	Limiting slenderness parameter for noncompact element	B4
λ_{rf}	Limiting slenderness parameter for noncompact flange	F3
λ_{rw}	Limiting slenderness parameter for noncompact web	F4
μ	Mean slip coefficient for class A or B surfaces, as applicable, or as established by tests	J3.8

ϕ	Resistance factor, specified in Chapters B through K	B3.3
ϕ_B	Resistance factor for bearing on concrete	I2.1
ϕ_b	Resistance factor for flexure	F1
ϕ_c	Resistance factor for compression	E1
ϕ_c	Resistance factor for axially loaded composite columns	I2.1b
ϕ_{sf}	Resistance factor for shear on the failure path	D5.1
ϕ_T	Resistance factor for torsion	H3.1
ϕ_t	Resistance factor for tension	D2
ϕ_v	Resistance factor for shear	G1
Ω	Safety factor	B3.4
Ω_B	Safety factor for bearing on concrete	I2.1
Ω_b	Safety factor for flexure	F1
Ω_c	Safety factor for compression	E1
Ω_c	Safety factor for axially loaded composite columns	I2.1b
Ω_{sf}	Safety factor for shear on the failure path	D5.1
Ω_t	Safety factor for torsion	H3.1
Ω_t	Safety factor for tension	D2
Ω_v	Safety factor for shear	G1
ρ_{sr}	Minimum reinforcement ratio for longitudinal reinforcing	I2.1
θ	Angle of loading measured from the weld longitudinal axis, degrees	J2.4
θ	Acute angle between the branch and chord, degrees	K2.1
ϵ_{cu}	Strain corresponding to compressive strength, f'_c	App. 4.2
τ_b	Parameter for reduced flexural stiffness using the direct analysis method	App. 7.3

GLOSSARY

Terms that appear in this Glossary are *italicized* throughout the Specification, where they first appear within a sub-section.

Notes:

- (1) Terms designated with † are common AISI-AISC terms that are coordinated between the two standards developers.
- (2) Terms designated with * are usually qualified by the type of *load effect*, for example, *nominal tensile strength*, *available compressive strength*, *design flexural strength*.
- (3) Terms designated with ** are usually qualified by the type of component, for example, *web local buckling*, *flange local bending*.

*Allowable strength** †. *Nominal strength* divided by the *safety factor*, R_n/Ω .

Allowable stress. *Allowable strength* divided by the appropriate section property, such as section modulus or cross-section area.

Amplification factor. Multiplier of the results of *first-order analysis* to reflect *second-order* effects.

Applicable building code †. Building code under which the structure is designed.

ASD (Allowable Strength Design) †. Method of proportioning *structural components* such that the *allowable strength* equals or exceeds the *required strength* of the component under the action of the *ASD load combinations*.

ASD load combination †. Load combination in the *applicable building code* intended for allowable strength design (*allowable stress design*).

Authority having jurisdiction. Organization, political subdivision, office or individual charged with the responsibility of administering and enforcing the provisions of the *applicable building code*.

*Available strength** †. *Design strength* or *allowable strength*, as appropriate.

*Available stress**. *Design stress* or *allowable stress*, as appropriate.

Average rib width. Average width of the rib of a corrugation in a *formed steel deck*.

Batten plate. Plate rigidly connected to two parallel components of a built-up *column* or *beam* designed to transmit shear between the components.

Beam. Structural member that has the primary function of resisting bending moments.

Beam-column. Structural member that resists both axial force and bending moment.

Bearing. In a bolted connection, *limit state* of shear forces transmitted by the bolt to the connection elements.

Bearing (local compressive yielding). Limit state of local compressive yielding due to the action of a member bearing against another member or surface.

Bearing-type connection. Bolted *connection* where shear forces are transmitted by the bolt bearing against the connection elements.

Block shear rupture. In a connection, *limit state* of tension fracture along one path and shear yielding or shear fracture along another path.

Braced frame†. An essentially vertical truss system that provides resistance to lateral forces and provides stability for the *structural system*.

Branch face. Wall of *HSS branch member*.

Branch member. For *HSS connections*, member that terminates at a *chord member* or *main member*.

Buckling. Limit state of sudden change in the geometry of a structure or any of its elements under a critical loading condition.

Buckling strength. Nominal strength for *buckling* or *instability limit states*.

Built-up member, cross-section, section, shape. Member, cross-section, section or shape fabricated from structural steel elements that are welded or bolted together.

Camber. Curvature fabricated into a beam or truss so as to compensate for deflection induced by loads.

Charpy V-Notch impact test. Standard dynamic test measuring notch toughness of a specimen.

Chord member. For *HSS*, primary member that extends through a truss *connection*.

Cladding. Exterior covering of structure.

Cold-formed steel structural member†. Shape manufactured by press-braking blanks sheared from sheets, cut lengths of coils or plates, or by roll forming cold- or hot-rolled coils or sheets; both forming operations being performed at ambient room temperature, that is, without manifest addition of heat such as would be required for hot forming.

Column. Structural member that has the primary function of resisting axial force.

Combined system. Structure comprised of two or more lateral load-resisting systems of different type.

Compact section. Section capable of developing a fully plastic stress distribution and possessing a *rotation capacity* of approximately three before the onset of local buckling.

Complete-joint-penetration groove weld (CJP). Groove weld in which weld metal extends through the joint thickness, except as permitted for *HSS connections*.

Composite. Condition in which steel and concrete elements and members work as a unit in the distribution of internal forces.

- Concrete crushing.* Limit state of compressive failure in concrete having reached the ultimate strain.
- Concrete haunch.* Section of solid concrete that results from stopping the deck on each side of the girder in a *composite* floor system constructed using a *formed steel deck*.
- Concrete-encased beam.* Beam totally encased in concrete cast integrally with the slab.
- Connection*†. Combination of structural elements and *joints* used to transmit forces between two or more members.
- Cope.* Cutout made in a structural member to remove a flange and conform to the shape of an intersecting member.
- Cover plate.* Plate welded or bolted to the flange of a member to increase cross-sectional area, section modulus or moment of inertia.
- Cross connection.* *HSS connection* in which forces in *branch members* or connecting elements transverse to the *main member* are primarily equilibrated by forces in other branch members or connecting elements on the opposite side of the main member.
- Design load**†. Applied *load* determined in accordance with either *LFRD load combinations* or *ASD load combinations*, whichever is applicable.
- Design strength**†. *Resistance factor* multiplied by the *nominal strength*, ϕR_n .
- Design stress range.* Magnitude of change in stress due to the repeated application and removal of service live *loads*. For locations subject to stress reversal it is the algebraic difference of the peak stresses.
- Design stress**. *Design strength* divided by the appropriate section property, such as section modulus or cross section area.
- Design wall thickness.* *HSS wall thickness* assumed in the determination of section properties.
- Diagonal bracing.* Inclined structural member carrying primarily axial force in a *braced frame*.
- Diagonal stiffener.* Web stiffener at column panel zone oriented diagonally to the flanges, on one or both sides of the web.
- Diaphragm plate.* Plate possessing in-plane shear stiffness and strength, used to transfer forces to the supporting elements.
- Diaphragm*†. Roof, floor or other membrane or bracing system that transfers in-plane forces to the lateral force resisting system.
- Direct analysis method.* Design method for stability that captures the effects of residual stresses and initial out-of-plumbness of frames by reducing stiffness and applying *notional loads* in a *second-order analysis*.

Direct bond interaction. Mechanism by which force is transferred between steel and concrete in a *composite* section by bond stress.

Distortional failure. Limit state of an HSS truss connection based on distortion of a rectangular HSS chord member into a rhomboidal shape.

Distortional stiffness. Out-of-plane flexural stiffness of web.

Double curvature. Deformed shape of a beam with one or more inflection points within the span.

Double-concentrated forces. Two equal and opposite forces that form a couple on the same side of the loaded member.

Doubler. Plate added to, and parallel with, a *beam* or *column* web to increase resistance to concentrated forces.

Drift. Lateral deflection of structure.

Effective length factor, K. Ratio between the *effective length* and the unbraced length of the member.

Effective length. Length of an otherwise identical *column* with the same strength when analyzed with pinned end conditions.

Effective net area. Net area modified to account for the effect of shear lag.

Effective section modulus. Section modulus reduced to account for buckling of slender compression elements.

Effective width. Reduced width of a plate or slab with an assumed uniform stress distribution which produces the same effect on the behavior of a structural member as the actual plate or slab width with its nonuniform stress distribution.

Elastic analysis. *Structural analysis* based on the assumption that the structure returns to its original geometry on removal of the *load*.

Encased composite column. *Composite column* consisting of a *structural concrete column* and one or more embedded steel shapes.

End panel. Web panel with an adjacent panel on one side only.

End return. Length of *fillet weld* that continues around a corner in the same plane.

Engineer of record. Licensed professional responsible for sealing the contract documents.

Expansion rocker. Support with curved surface on which a member bears that can tilt to accommodate expansion.

Expansion roller. Round steel bar on which a member bears that can roll to accommodate expansion.

Eyebar. Pin-connected tension member of uniform thickness, with forged or thermally cut head of greater width than the body, proportioned to provide approximately equal strength in the head and body.

- Factored load*†. Product of a *load factor* and the *nominal load*.
- Fastener*. Generic term for bolts, rivets, or other connecting devices.
- Fatigue*. *Limit state* of crack initiation and growth resulting from repeated application of *live loads*.
- Faying surface*. Contact surface of connection elements transmitting a shear force.
- Filled composite column*. *Composite column* consisting of a shell of *HSS* or *pipe* filled with *structural concrete*.
- Filler metal*. Metal or alloy to be added in making a welded joint.
- Filler*. Plate used to build up the thickness of one component.
- Fillet weld reinforcement*. *Fillet welds* added to *groove welds*.
- Fillet weld*. Weld of generally triangular cross section made between intersecting surfaces of elements.
- First-order analysis*. *Structural analysis* in which equilibrium conditions are formulated on the undeformed structure; *second-order effects* are neglected.
- Fitted bearing stiffener*. *Stiffener* used at a support or concentrated *load* that fits tightly against one or both flanges of a *beam* so as to transmit load through bearing.
- Flare bevel groove weld*. Weld in a groove formed by a member with a curved surface in contact with a planar member.
- Flare V-groove weld*. Weld in a groove formed by two members with curved surfaces.
- Flat width*. Nominal width of rectangular *HSS* minus twice the outside corner radius. In absence of knowledge of the corner radius, the flat width may be taken as the total section width minus three times the thickness.
- Flexural buckling*. Buckling mode in which a compression member deflects laterally without twist or change in cross-sectional shape.
- Flexural-torsional buckling*†. Buckling mode in which a compression member bends and twists simultaneously without change in cross-sectional shape.
- Force*. Resultant of distribution of stress over a prescribed area.
- Formed section*. See *cold-formed steel structural member*.
- Formed steel deck*. In composite construction, *steel* cold formed into a decking profile used as a permanent concrete form.
- Fully restrained moment connection*. Connection capable of transferring moment with negligible rotation between connected members.
- Gage*. Transverse center-to-center spacing of *fasteners*.
- Gap connection*. *HSS truss connection* with a gap or space on the *chord* face between intersecting *branch members*.

General collapse. Limit state of chord plastification of opposing sides of a round HSS chord member at a cross-connection.

Geometric axis. Axis parallel to web, flange or angle leg.

Girder filler. Narrow piece of *sheet steel* used as a fill between the edge of a deck sheet and the flange of a girder in a *composite* floor system constructed using a *formed steel deck*.

Girder. See *Beam*.

Girt†. Horizontal structural member that supports wall panels and is primarily subjected to bending under horizontal *loads*, such as wind load.

Gouge. Relatively smooth surface groove or cavity resulting from plastic deformation or removal of material.

Gravity axis. Axis through the center of gravity of a member along its length.

Gravity frame. Portion of the framing system not included in the *lateral load resisting system*.

Gravity load. *Load*, such as that produced by dead and live loads, acting in the downward direction.

Grip (of bolt). Thickness of material through which a bolt passes.

Groove weld. Weld in a groove between connection elements. See also AWS D1.1.

Gusset plate. Plate element connecting truss members or a strut or brace to a *beam* or *column*.

Horizontal shear. Force at the interface between steel and concrete surfaces in a *composite beam*.

HSS. Square, rectangular or round hollow structural steel section produced in accordance with a *pipe* or tubing product specification.

User Note: A pipe can be designed using the same design rules for round HSS sections as long as it conforms to ASTM A53 Class B and the appropriate parameters are used in the design.

Inelastic analysis. *Structural analysis* that takes into account inelastic material behavior, including *plastic analysis*.

In-plane instability. Limit state of a *beam-column* bent about its major axis while *lateral buckling* or *lateral-torsional buckling* is prevented by *lateral bracing*.

Instability. Limit state reached in the loading of a structural component, frame or structure in which a slight disturbance in the *loads* or geometry produces large displacements.

Joint eccentricity. For HSS truss connection, perpendicular distance from *chord member* center of gravity to intersection of *branch member* work points.

Joint†. Area where two or more ends, surfaces, or edges are attached. Categorized by type of *fastener* or weld used and method of force transfer.

K-connection. *HSS connection* in which forces in *branch members* or connecting elements transverse to the *main member* are primarily equilibrated by forces in other branch members or connecting elements on the same side of the main member.

Lacing. Plate, angle or other steel shape, in a lattice configuration, that connects two steel shapes together.

Lap joint. Joint between two overlapping connection elements in parallel planes.

Lateral bracing. *Diagonal bracing*, *shear walls* or equivalent means for providing in-plane lateral stability.

Lateral load resisting system. Structural system designed to resist lateral loads and provide stability for the structure as a whole.

Lateral load. *Load*, such as that produced by wind or earthquake effects, acting in a lateral direction.

Lateral-torsional buckling. Buckling mode of a flexural member involving deflection normal to the plane of bending occurring simultaneously with twist about the shear center of the cross-section.

Leaning column. *Column* designed to carry *gravity loads* only, with *connections* that are not intended to provide resistance to *lateral loads*.

Length effects. Consideration of the reduction in strength of a member based on its *unbraced length*.

Limit state. Condition in which a structure or component becomes unfit for service and is judged either to be no longer useful for its intended function (*serviceability limit state*) or to have reached its ultimate load-carrying capacity (*strength limit state*).

Load†. Force or other action that results from the weight of building materials, occupants and their possessions, environmental effects, differential movement, or restrained dimensional changes.

Load effect†. Forces, stresses and deformations produced in a *structural component* by the applied *loads*.

Load factor†. Factor that accounts for deviations of the *nominal load* from the actual *load*, for uncertainties in the analysis that transforms the load into a *load effect* and for the probability that more than one extreme load will occur simultaneously.

*Local bending****. Limit state* of large deformation of a flange under a concentrated tensile force.

*Local buckling****. Limit state* of buckling of a compression element within a cross section.

*Local crippling****. Limit state* of local failure of web plate in the immediate vicinity of a concentrated *load* or reaction.

*Local yielding****.* Yielding that occurs in a local area of an element.

LRFD (Load and Resistance Factor Design)†. Method of proportioning *structural components* such that the *design strength* equals or exceeds the *required strength* of the component under the action of the *LRFD load combinations*.

LRFD load combination†. Load combination in the *applicable building code* intended for strength design (*load and resistance factor design*).

Main member. For *HSS connections*, *chord member*, column or other HSS member to which *branch members* or other connecting elements are attached.

Mechanism. Structural system that includes a sufficient number of real hinges, plastic hinges or both, so as to be able to articulate in one or more rigid body modes.

Mill scale. Oxide surface coating on steel formed by the hot rolling process.

Milled surface. Surface that has been machined flat by a mechanically guided tool to a flat, smooth condition.

Moment connection. Connection that transmits bending moment between connected members.

Moment frame†. Framing system that provides resistance to lateral loads and provides stability to the *structural system*, primarily by shear and flexure of the framing members and their connections.

Net area. Gross area reduced to account for removed material.

Nodal brace. Brace that prevents lateral movement or twist independently of other braces at adjacent brace points (see *relative brace*).

Nominal dimension. Designated or theoretical dimension, as in the tables of section properties.

Nominal load†. Magnitude of the *load* specified by the *applicable building code*.

Nominal rib height. Height of *formed steel deck* measured from the underside of the lowest point to the top of the highest point.

*Nominal strength**†. Strength of a structure or component (without the *resistance factor* or *safety factor* applied) to resist *load effects*, as determined in accordance with this *Specification*.

Noncompact section. Section that can develop the *yield stress* in its compression elements before *local buckling* occurs, but cannot develop a *rotation capacity* of three.

Nondestructive testing. Inspection procedure wherein no material is destroyed and integrity of the material or component is not affected.

Notch toughness. Energy absorbed at a specified temperature as measured in the Charpy V-Notch test.

Notional load. Virtual load applied in a structural analysis to account for destabilizing effects that are not otherwise accounted for in the design provisions.

Out-of-plane buckling. Limit state of a beam-column bent about its major axis while lateral buckling or lateral-torsional buckling is not prevented by lateral bracing.

Overlap connection. HSS truss connection in which intersecting branch members overlap.

Panel zone. Web area of beam-to-column connection delineated by the extension of beam and column flanges through the connection, transmitting moment through a shear panel.

Partial-joint-penetration groove weld (PJP). Groove weld in which the penetration is intentionally less than the complete thickness of the connected element.

Partially restrained moment connection. Connection capable of transferring moment with rotation between connected members that is not negligible.

Percent elongation. Measure of ductility, determined in a tensile test as the maximum elongation of the gage length divided by the original gage length.

Permanent load†. Load in which variations over time are rare or of small magnitude. All other loads are variable loads.

Pipe. See HSS.

Pitch. Longitudinal center-to-center spacing of fasteners. Center-to-center spacing of bolt threads along axis of bolt.

Plastic analysis. Structural analysis based on the assumption of rigid-plastic behavior, in other words, that equilibrium is satisfied throughout the structure and the stress is at or below the yield stress.

Plastic hinge. Yielded zone that forms in a structural member when the plastic moment is attained. The member is assumed to rotate further as if hinged, except that such rotation is restrained by the plastic moment.

Plastic moment. Theoretical resisting moment developed within a fully yielded cross section.

Plastic stress distribution method. Method for determining the stresses in a composite member assuming that the steel section and the concrete in the cross section are fully plastic.

Plastification. In an HSS connection, limit state based on an out-of-plane flexural yield line mechanism in the chord at a branch member connection.

Plate girder. Built-up beam.

Plug weld. Weld made in a circular hole in one element of a joint fusing that element to another element.

- Ponding*. Retention of water due solely to the deflection of flat roof framing.
- Post-buckling strength*. Load or force that can be carried by an element, member, or frame after initial buckling has occurred.
- Pretensioned joint*. Joint with high-strength bolts tightened to the specified minimum pretension.
- Properly developed*. Reinforcing bars detailed to yield in a ductile manner before crushing of the concrete occurs. Bars meeting the provisions of ACI 318 insofar as development length, spacing and cover shall be deemed to be properly developed.
- Prying action*. Amplification of the tension force in a bolt caused by leverage between the point of applied load, the bolt and the reaction of the connected elements.
- Punching load*. Component of *branch member* force perpendicular to a *chord*.
- Purlin*†. Horizontal structural member that supports roof deck and is primarily subjected to bending under vertical loads such as snow, wind or dead loads.
- P- δ effect*. Effect of *loads* acting on the deflected shape of a member between joints or nodes.
- P- Δ effect*. Effect of *loads* acting on the displaced location of joints or nodes in a structure. In tiered building structures, this is the effect of *loads* acting on the laterally displaced location of floors and roofs.
- Quality assurance*. System of shop and field activities and controls implemented by the owner or his/her designated representative to provide confidence to the owner and the building authority that quality requirements are implemented.
- Quality control*. System of shop and field controls implemented by the fabricator and erector to ensure that contract and company fabrication and erection requirements are met.
- Rational engineering analysis*†. *Analysis* based on theory that is appropriate for the situation, relevant test data if available, and sound engineering judgment.
- Reentrant*. In a *cope* or weld access hole, a cut at an abrupt change in direction in which the exposed surface is concave.
- Relative brace*. Brace that controls the relative movement of two adjacent brace points along the length of a *beam* or *column* or the relative lateral displacement of two stories in a frame (see *nodal brace*).
- Required strength**†. Forces, stresses and deformations acting on the *structural component*, determined by either *structural analysis*, for the *LRFD* or *ASD load combinations*, as appropriate, or as specified by this *Specification* or Standard.
- Resistance factor*, ϕ †. Factor that accounts for unavoidable deviations of the *nominal strength* from the actual strength and for the manner and consequences of failure.
- Reverse curvature*. See *double curvature*.
- Root of joint*. Portion of a *joint* to be welded where the members are closest to each other.

Rotation capacity. Incremental angular rotation that a given shape can accept prior to excessive load shedding, defined as the ratio of the inelastic rotation attained to the idealized elastic rotation at first yield.

Rupture strength. In a *connection*, strength limited by tension or shear rupture.

Safety factor, Ω_f . Factor that accounts for deviations of the actual strength from the nominal strength, deviations of the actual *load* from the *nominal load*, uncertainties in the analysis that transforms the load into a *load effect*, and for the manner and consequences of failure.

Second-order analysis. Structural analysis in which equilibrium conditions are formulated on the deformed structure; *second-order effects* (both $P-\delta$ and $P-\Delta$, unless specified otherwise) are included.

Second-order effect. Effect of *loads* acting on the deformed configuration of a structure; includes $P-\delta$ *effect* and $P-\Delta$ *effect*.

Seismic response modification coefficient. Factor that reduces seismic *load effects* to strength level.

Service load combination. Load combination under which serviceability limit states are evaluated.

Service load \dagger . Load under which *serviceability limit states* are evaluated.

Serviceability limit state. Limiting condition affecting the ability of a structure to preserve its appearance, maintainability, durability or the comfort of its occupants or function of machinery, under normal usage.

Shear buckling. Buckling mode in which a plate element, such as the web of a beam, deforms under pure shear applied in the plane of the plate.

Shear connector. Headed stud, channel, plate or other shape welded to a steel member and embedded in concrete of a *composite member* to transmit shear forces at the interface between the two materials.

Shear connector strength. *Limit state* of reaching the strength of a *shear connector*, as governed by the connector bearing against the concrete in the slab or by the *tensile strength* of the connector.

Shear rupture. *Limit state of rupture (fracture) due to shear.*

Shear wall \dagger . Wall that provides resistance to lateral loads in the plane of the wall and provides stability for the structural system.

Shear yielding. *Yielding* that occurs due to shear.

Shear yielding (punching). In an HSS connection, *limit state* based on out-of-plane shear strength of the *chord wall* to which *branch members* are attached.

Sheet steel. In a composite floor system, steel used for closure plates or miscellaneous trimming in a *formed steel deck*.

- Shim*. Thin layer of material used to fill a space between faying or bearing surfaces.
- Sideways buckling. Limit state* of lateral buckling of the tension flange opposite the location of a concentrated compression force.
- Sidewall crippling. Limit state* of *web crippling* of the sidewalls of a *chord member* at a *HSS truss connection*.
- Sidewall crushing. Limit state* based on bearing strength of *chord member* sidewall in *HSS truss connection*.
- Simple connection*. Connection that transmits negligible bending moment between connected members.
- Single-concentrated force*. Tensile or compressive force applied normal to the flange of a member.
- Single curvature*. Deformed shape of a beam with no inflection point within the span.
- Slender-element section*. Cross section possessing plate components of sufficient slenderness such that *local buckling* in the elastic range will occur.
- Slip*. In a bolted connection, *limit state* of relative motion of connected parts prior to the attainment of the *available strength* of the connection.
- Slip-critical connection*. Bolted *connection* designed to resist movement by friction on the faying surface of the connection under the clamping forces of the bolts.
- Slot weld*. Weld made in an elongated hole fusing an element to another element.
- Snug-tightened joint*. Joint with the connected plies in firm contact as specified in Chapter J.
- Specified minimum tensile strength*. Lower limit of *tensile strength* specified for a material as defined by ASTM.
- Specified minimum yield stress*[†]. Lower limit of *yield stress* specified for a material as defined by ASTM.
- Splice. Connection* between two structural elements joined at their ends to form a single, longer element.
- Stability*. Condition reached in the loading of a structural component, frame or structure in which a slight disturbance in the *loads* or geometry does not produce large displacements.
- Stiffened element*. Flat compression element with adjoining out-of-plane elements along both edges parallel to the direction of loading.
- Stiffener*. Structural element, usually an angle or plate, attached to a *member* to distribute *load*, transfer shear or prevent buckling.
- Stiffness*. Resistance to deformation of a member or structure, measured by the ratio of the applied force (or moment) to the corresponding displacement (or rotation).

Strain compatibility method. Method for determining the stresses in a composite member considering the stress-strain relationships of each material and its location with respect to the neutral axis of the cross section.

Strength limit state. Limiting condition affecting the safety of the structure, in which the ultimate load-carrying capacity is reached.

Stress. Force per unit area caused by axial force, moment, shear or torsion.

Stress concentration. Localized stress considerably higher than average (even in uniformly loaded cross sections of uniform thickness) due to abrupt changes in geometry or localized loading.

Strong axis. Major principal centroidal axis of a cross section.

Structural analysis†. Determination of *load effects* on members and *connections* based on principles of structural mechanics.

Structural component†. Member, connector, connecting element or assemblage.

Structural steel. Steel elements as defined in Section 2.1 of the AISC *Code of Standard Practice for Steel Buildings and Bridges*.

Structural system. An assemblage of load-carrying components that are joined together to provide interaction or interdependence.

T-connection. *HSS connection* in which the *branch member* or connecting element is perpendicular to the *main member* and in which forces transverse to the main member are primarily equilibrated by shear in the main member.

Tensile rupture. *Limit state* of rupture (fracture) due to tension.

Tensile strength (of material)†. Maximum tensile stress that a material is capable of sustaining as defined by ASTM.

Tensile strength (of member). Maximum tension force that a member is capable of sustaining.

Tensile yielding. Yielding that occurs due to tension.

Tension and shear rupture. In a bolt, *limit state* of rupture (fracture) due to simultaneous tension and shear force.

Tension field action. Behavior of a panel under shear in which diagonal tensile forces develop in the web and compressive forces develop in the *transverse stiffeners* in a manner similar to a Pratt truss.

Thermally cut. Cut with gas, plasma or laser.

Tie plate. Plate element used to join two parallel components of a *built-up column*, girder or strut rigidly connected to the parallel components and designed to transmit shear between them.

Toe of fillet. Junction of a fillet weld face and base metal. Tangent point of a rolled section fillet.

Torsional bracing. Bracing resisting twist of a *beam* or *column*.

Torsional buckling. Buckling mode in which a compression member twists about its shear center axis.

Torsional yielding. Yielding that occurs due to torsion.

Transverse reinforcement. Steel reinforcement in the form of closed ties or welded wire fabric providing confinement for the concrete surrounding the steel shape core in an *encased concrete composite column*.

Transverse stiffener. Web *stiffener* oriented perpendicular to the flanges, attached to the web.

Tubing. See *HSS*.

Turn-of-nut method. Procedure whereby the specified pretension in high-strength bolts is controlled by rotating the fastener component a predetermined amount after the bolt has been snug tightened.

Unbraced length. Distance between braced points of a member, measured between the centers of gravity of the bracing members.

Uneven load distribution. In an *HSS connection*, condition in which the load is not distributed through the cross section of connected elements in a manner that can be readily determined.

Unframed end. The end of a member not restrained against rotation by stiffeners or connection elements.

Unstiffened element. Flat compression element with an adjoining out-of-plane element along one edge parallel to the direction of loading.

Variable load[†]. Load not classified as *permanent load*.

Vertical bracing system. System of *shear walls*, *braced frames* or both, extending through one or more floors of a building.

Weak axis. Minor principal centroidal axis of a cross section.

Weathering steel. High-strength, low-alloy steel that, with suitable precautions, can be used in normal atmospheric exposures (not marine) without protective paint coating.

Web buckling. *Limit state* of lateral instability of a web.

Web compression buckling. *Limit state* of out-of-plane compression buckling of the web due to a concentrated compression force.

Web sidesway buckling. *Limit state* of lateral buckling of the tension flange opposite the location of a concentrated compression force.

Weld metal. Portion of a fusion weld that has been completely melted during welding.

Weld metal has elements of filler metal and base metal melted in the weld thermal cycle.

Weld root. See *root of joint*.

Y-connection. HSS connection in which the *branch member* or connecting element is not perpendicular to the *main member* and in which forces transverse to the main member are primarily equilibrated by shear in the main member.

Yield moment. In a member subjected to bending, the moment at which the extreme outer fiber first attains the *yield stress*.

Yield point†. First stress in a material at which an increase in strain occurs without an increase in stress as defined by ASTM.

Yield strength†. Stress at which a material exhibits a specified limiting deviation from the proportionality of stress to strain as defined by ASTM.

Yield stress†. Generic term to denote either *yield point* or *yield strength*, as appropriate for the material.

Yielding. Limit state of inelastic deformation that occurs after the *yield stress* is reached.

Yielding (plastic moment). Yielding throughout the cross section of a member as the bending moment reaches the *plastic moment*.

Yielding (yield moment). Yielding at the extreme fiber on the cross section of a member when the bending moment reaches the *yield moment*.

CHAPTER A

GENERAL PROVISIONS

This chapter states the scope of the Specification, summarizes referenced specification, code, and standard documents, and provides requirements for materials and contract documents.

The chapter is organized as follows:

- A1. Scope
- A2. Referenced Specifications, Codes and Standards
- A3. Material
- A4. Structural Design Drawings and Specifications

A1. SCOPE

The *Specification for Structural Steel Buildings*, hereafter referred to as the Specification, shall apply to the design of the *structural steel* system, where the steel elements are defined in the *AISC Code of Standard Practice for Steel Buildings and Bridges*, Section 2.1.

This Specification includes the Symbols, the Glossary, Chapters A through M, and Appendices 1 through 7. The Commentary and the User Notes interspersed throughout are not part of the Specification.

User Note: User notes are intended to provide concise and practical guidance in the application of the provisions.

This Specification sets forth criteria for the design, fabrication, and erection of *structural steel* buildings and other structures, where other structures are defined as those structures designed, fabricated, and erected in a manner similar to buildings, with building-like vertical and lateral load resisting elements. Where conditions are not covered by the Specification, designs are permitted to be based on tests or analysis, subject to the approval of the *authority having jurisdiction*. Alternate methods of analysis and design shall be permitted, provided such alternate methods or criteria are acceptable to the authority having jurisdiction.

User Note: For the design of structural members, other than hollow structural sections (*HSS*), that are cold-formed to shapes, with elements not more than 1 in. (25 mm) in thickness, the provisions in the *AISI North American Specification for the Design of Cold-Formed Steel Structural Members* are recommended.

1. Low-Seismic Applications

When the *seismic response modification coefficient, R*, (as specified in the *applicable building code*) is taken equal to or less than 3, the design, fabrication, and erection of structural-steel-framed buildings and other structures shall comply with this Specification.

2. High-Seismic Applications

When the *seismic response modification coefficient, R*, (as specified in the *applicable building code*) is taken greater than 3, the design, fabrication and erection of structural-steel-framed buildings and other structures shall comply with the requirements in the *Seismic Provisions for Structural Steel Buildings* (ANSI/AISC 341), in addition to the provisions of this Specification.

3. Nuclear Applications

The design of nuclear structures shall comply with the requirements of the *Specification for the Design, Fabrication, and Erection of Steel Safety-Related Structures in Nuclear Facilities* (ANSI/AISC N690) including Supplement No. 2 or the *Load and Resistance Factor Design Specification for Steel Safety-Related Structures for Nuclear Facilities* (ANSI/AISC N690L), in addition to the provisions of this Specification.

A2. REFERENCED SPECIFICATIONS, CODES AND STANDARDS

The following specifications, codes and standards are referenced in this Specification:

ACI International (ACI)

ACI 318-02 *Building Code Requirements for Structural Concrete and Commentary*

ACI 318M-02 *Metric Building Code Requirements for Structural Concrete and Commentary*

American Institute of Steel Construction, Inc. (AISC)

AISC 303-05 *Code of Standard Practice for Steel Buildings and Bridges*

ANSI/AISC 341-05 *Seismic Provisions for Structural Steel Buildings*

ANSI/AISC N690-1994(R2004) *Specification for the Design, Fabrication and Erection of Steel Safety-Related Structures for Nuclear Facilities*, including Supplement No. 2

ANSI/AISC N690L-03 *Load and Resistance Factor Design Specification for Steel Safety-Related Structures for Nuclear Facilities*

American Society of Civil Engineers (ASCE)

SEI/ASCE 7-02 *Minimum Design Loads for Buildings and Other Structures*

ASCE/SFPE 29-99 *Standard Calculation Methods for Structural Fire Protection*

American Society of Mechanical Engineers (ASME)

ASME B18.2.6-96 *Fasteners for Use in Structural Applications*

ASME B46.1-95 *Surface Texture, Surface Roughness, Waviness, and Lay*

ASTM International (ASTM)

- A6/A6M-04a *Standard Specification for General Requirements for Rolled Structural Steel Bars, Plates, Shapes, and Sheet Piling*
- A36/A36M-04 *Standard Specification for Carbon Structural Steel*
- A53/A53M-02 *Standard Specification for Pipe, Steel, Black and Hot-Dipped, Zinc-Coated, Welded and Seamless*
- A193/A193M-04a *Standard Specification for Alloy-Steel and Stainless Steel Bolt- ing Materials for High-Temperature Service*
- A194/A194M-04 *Standard Specification for Carbon and Alloy Steel Nuts for Bolts for High Pressure or High-Temperature Service, or Both*
- A216/A216M-93(2003) *Standard Specification for Steel Castings, Carbon, Suit- able for Fusion Welding, for High Temperature Service*
- A242/A242M-04 *Standard Specification for High-Strength Low-Alloy Structural Steel*
- A283/A283M-03 *Standard Specification for Low and Intermediate Tensile Strength Carbon Steel Plates*
- A307-03 *Standard Specification for Carbon Steel Bolts and Studs, 60,000 PSI Tensile Strength*
- A325-04 *Standard Specification for Structural Bolts, Steel, Heat Treated, 120/105 ksi Minimum Tensile Strength*
- A325M-04 *Standard Specification for High-Strength Bolts for Structural Steel Joints (Metric)*
- A354-03a *Standard Specification for Quenched and Tempered Alloy Steel Bolts, Studs, and Other Externally Threaded Fasteners*
- A370-03a *Standard Test Methods and Definitions for Mechanical Testing of Steel Products*
- A449-04 *Standard Specification for Quenched and Tempered Steel Bolts and Studs*
- A490-04 *Standard Specification for Heat-Treated Steel Structural Bolts, 150 ksi Minimum Tensile Strength*
- A490M-04 *Standard Specification for High-Strength Steel Bolts, Classes 10.9 and 10.9.3, for Structural Steel Joints (Metric)*
- A500-03a *Standard Specification for Cold-Formed Welded and Seamless Carbon Steel Structural Tubing in Rounds and Shapes*
- A501-01 *Standard Specification for Hot-Formed Welded and Seamless Carbon Steel Structural Tubing*
- A502-03 *Standard Specification for Steel Structural Rivets*
- A514/A514M-00a *Standard Specification for High-Yield Strength, Quenched and Tempered Alloy Steel Plate, Suitable for Welding*
- A529/A529M-04 *Standard Specification for High-Strength Carbon-Manganese Steel of Structural Quality*
- A563-04 *Standard Specification for Carbon and Alloy Steel Nuts*
- A563M-03 *Standard Specification for Carbon and Alloy Steel Nuts [Metric]*
- A568/A568M-03 *Standard Specification for Steel, Sheet, Carbon, and High- Strength, Low-Alloy, Hot-Rolled and Cold-Rolled, General Requirements for*

- A572/A572M-04 *Standard Specification for High-Strength Low-Alloy Columbium-Vanadium Structural Steel*
- A588/A588M-04 *Standard Specification for High-Strength Low-Alloy Structural Steel with 50 ksi [345 MPa] Minimum Yield Point to 4 in. [100 mm] Thick*
- A606-04 *Standard Specification for Steel, Sheet and Strip, High-Strength, Low-Alloy, Hot-Rolled and Cold-Rolled, with Improved Atmospheric Corrosion Resistance*
- A618/A618M-04 *Standard Specification for Hot-Formed Welded and Seamless High-Strength Low-Alloy Structural Tubing*
- A673/A673M-04 *Standard Specification for Sampling Procedure for Impact Testing of Structural Steel*
- A668/A668M-04 *Standard Specification for Steel Forgings, Carbon and Alloy, for General Industrial Use*
- A709/A709M-04 *Standard Specification for Carbon and High-Strength Low-Alloy Structural Steel Shapes, Plates, and Bars and Quenched-and-Tempered Alloy Structural Steel Plates for Bridges*
- A751-01 *Standard Test Methods, Practices, and Terminology for Chemical Analysis of Steel Products*
- A847-99a(2003) *Standard Specification for Cold-Formed Welded and Seamless High-Strength, Low-Alloy Structural Tubing with Improved Atmospheric Corrosion Resistance*
- A852/A852M-03 *Standard Specification for Quenched and Tempered Low-Alloy Structural Steel Plate with 70 ksi [485 MPa] Minimum Yield Strength to 4 in. [100 mm] Thick*
- A913/A913M-04 *Standard Specification for High-Strength Low-Alloy Steel Shapes of Structural Quality, Produced by Quenching and Self-Tempering Process (QST)*
- A992/A992M-04 *Standard Specification for Steel for Structural Shapes for Use in Building Framing*

User Note: ASTM A992 is the most commonly referenced specification for W shapes.

- A1011/A1011M-04 *Standard Specification for Steel, Sheet and Strip, Hot-Rolled, Carbon, Structural, High-Strength Low-Alloy and High-Strength Low-Alloy with Improved Formability*
- C33-03 *Standard Specification for Concrete Aggregates*
- C330-04 *Standard Specification for Lightweight Aggregates for Structural Concrete*
- E119-00a *Standard Test Methods for Fire Tests of Building Construction and Materials*
- E709-01 *Standard Guide for Magnetic Particle Examination*
- F436-03 *Standard Specification for Hardened Steel Washers*
- F959-02 *Standard Specification for Compressible-Washer-Type Direct Tension Indicators for Use with Structural Fasteners*

F1554-99 *Standard Specification for Anchor Bolts, Steel, 36, 55, and 105 ksi Yield Strength*

User Note: ASTM F1554 is the most commonly referenced specification for anchor rods. Grade and weldability must be specified.

F1852-04 *Standard Specification for “Twist-Off” Type Tension Control Structural Bolt/Nut/Washer Assemblies, Steel, Heat Treated, 120/105 ksi Minimum Tensile Strength*

American Welding Society (AWS)

AWS D1.1/D1.1M-2004 *Structural Welding Code–Steel*

AWS A5.1-2004 *Specification for Carbon Steel Electrodes for Shielded Metal Arc Welding*

AWS A5.5-96 *Specification for Low-Alloy Steel Electrodes for Shielded Metal Arc Welding*

AWS A5.17/A5.17M-97 *Specification for Carbon Steel Electrodes and Fluxes for Submerged Arc Welding*

AWS A5.18:2001 *Specification for Carbon Steel Electrodes and Rods for Gas Shielded Arc Welding*

AWS A5.20-95 *Specification for Carbon Steel Electrodes for Flux Cored Arc Welding*

AWS A5.23/A5.23M-97 *Specification for Low-Alloy Steel Electrodes and Fluxes for Submerged Arc Welding*

AWS A5.25/A5.25M-97 *Specification for Carbon and Low-Alloy Steel Electrodes and Fluxes for Electroslag Welding*

AWS A5.26/A5.26M-97 *Specification for Carbon and Low-Alloy Steel Electrodes for Electrogas Welding*

AWS A5.28-96 *Specification for Low-Alloy Steel Electrodes and Rods for Gas Shielded Arc Welding*

AWS A5.29:1998 *Specification for Low-Alloy Steel Electrodes for Flux Cored Arc Welding*

Research Council on Structural Connections (RCSC)

Specification for Structural Joints Using ASTM A325 or A490 Bolts, 2004

A3. MATERIAL

1. Structural Steel Materials

Material test reports or reports of tests made by the fabricator or a testing laboratory shall constitute sufficient evidence of conformity with one of the above listed ASTM standards. For hot-rolled structural shapes, plates, and bars, such tests shall be made in accordance with ASTM A6/A6M; for sheets, such tests shall be made in accordance with ASTM A568/A568M; for *tubing* and *pipe*, such tests shall be made in accordance with the requirements of the applicable ASTM standards listed above for those product forms. If requested, the fabricator shall provide an

affidavit stating that the *structural steel* furnished meets the requirements of the grade specified.

1a. ASTM Designations

Structural steel material conforming to one of the following ASTM specifications is approved for use under this Specification:

(1) Hot-rolled structural shapes

ASTM A36/A36M
ASTM A529/A529M
ASTM A572/A572M
ASTM A588/A588M
ASTM A709/A709M
ASTM A913/A913M
ASTM A992/ A992M

(2) Structural tubing

ASTM A500
ASTM A501
ASTM A618
ASTM A847

(3) Pipe

ASTM A53/A53M, Gr. B

(4) Plates

ASTM A36/A36M
ASTM A242/A242M
ASTM A283/A283M
ASTM A514/A514M
ASTM A529/A529M
ASTM A572/A572M
ASTM A588/A588M
ASTM A709/A709M
ASTM A852/A852M
ASTM A1011/A1011M

(5) Bars

ASTM A36/A36M
ASTM A529/A529M
ASTM A572/A572M
ASTM A709/A709M

(6) Sheets

ASTM A606
A1011/A1011M SS, HSLAS, AND HSLAS-F

1b. Unidentified Steel

Unidentified steel free of injurious defects is permitted to be used for unimportant members or details, where the precise physical properties and weldability of the steel would not affect the strength of the structure.

1c. Rolled Heavy Shapes

ASTM A6/A6M hot-rolled shapes with a flange thickness exceeding 2 in. (50 mm), used as members subject to primary (computed) tensile *forces* due to tension or flexure and spliced using *complete-joint-penetration groove welds* that fuse through the thickness of the member, shall be specified as follows. The contract documents shall require that such shapes be supplied with *Charpy V-Notch (CVN) impact test* results in accordance with ASTM A6/A6M, Supplementary Requirement S30, *Charpy V-Notch Impact Test for Structural Shapes – Alternate Core Location*. The impact test shall meet a minimum average value of 20 ft-lbs (27 J) absorbed energy at +70 °F (+21 °C).

The above requirements do not apply if the *splices* and *connections* are made by bolting. The above requirements do not apply to hot-rolled shapes with a flange thickness exceeding 2 in. (50 mm) that have shapes with flange or web elements less than 2 in. (50 mm) thick welded with *complete-joint-penetration groove welds* to the face of the shapes with thicker elements.

User Note: Additional requirements for joints in heavy rolled members are given in Sections J1.5, J1.6, J2.7, and M2.2.

1d. Built-Up Heavy Shapes

Built-up cross-sections consisting of plates with a thickness exceeding 2 in. (50 mm), used as members subject to primary (computed) tensile *forces* due to tension or flexure and spliced or connected to other members using *complete-joint-penetration groove welds* that fuse through the thickness of the plates, shall be specified as follows. The contract documents shall require that the steel be supplied with *Charpy V-Notch impact test* results in accordance with ASTM A6/A6M, Supplementary Requirement S5, *Charpy V-Notch Impact Test*. The impact test shall be conducted in accordance with ASTM A673/A673M, Frequency P, and shall meet a minimum average value of 20 ft-lbs (27 J) absorbed energy at +70 °F (+21 °C).

The above requirements also apply to built-up cross-sections consisting of plates exceeding 2 in. (50 mm) that are welded with *complete-joint-penetration groove welds* to the face of other sections.

User Note: Additional requirements for joints in heavy built-up members are given in Sections J1.5, J1.6, J2.7, and M2.2.

2. Steel Castings and Forgings

Cast steel shall conform to ASTM A216/A216M, Gr. WCB with Supplementary Requirement S11. Steel forgings shall conform to ASTM A668/A668M. Test

reports produced in accordance with the above reference standards shall constitute sufficient evidence of conformity with such standards.

3. Bolts, Washers and Nuts

Bolt, washer, and nut material conforming to one of the following ASTM specifications is approved for use under this Specification:

(1) Bolts:

ASTM A307
ASTM A325
ASTM A325M
ASTM A449
ASTM A490
ASTM A490M
ASTM F1852

(2) Nuts:

ASTM A194/A194M
ASTM A563
ASTM A563M

(3) Washers:

ASTM F436
ASTM F436M

(4) Compressible-Washer-Type Direct Tension Indicators:

ASTM F959
ASTM F959M

Manufacturer's certification shall constitute sufficient evidence of conformity with the standards.

4. Anchor Rods and Threaded Rods

Anchor rod and threaded rod material conforming to one of the following ASTM specifications is approved for use under this Specification:

ASTM A36/A36M
ASTM A193/A193M
ASTM A354
ASTM A449
ASTM A572/A572M
ASTM A588/A588M
ASTM F1554

User Note: ASTM F1554 is the preferred material specification for anchor rods.

A449 material is acceptable for high-strength anchor rods and threaded rods of any diameter.

Threads on anchor rods and threaded rods shall conform to the Unified Standard Series of ASME B18.2.6 and shall have Class 2A tolerances.

Manufacturer's certification shall constitute sufficient evidence of conformity with the standards.

5. Filler Metal and Flux for Welding

Filler metals and fluxes shall conform to one of the following specifications of the American Welding Society:

AWS A5.1

AWS A5.5

AWS A5.17/A5.17M

AWS A5.18

AWS A5.20

AWS A5.23/A5.23M

AWS A5.25/A5.25M

AWS A5.26/A5.26M

AWS A5.28

AWS A5.29

AWS A5.32/A5.32M

Manufacturer's certification shall constitute sufficient evidence of conformity with the standards. Filler metals and fluxes that are suitable for the intended application shall be selected.

6. Stud Shear Connectors

Steel stud *shear connectors* shall conform to the requirements of *Structural Welding Code—Steel*, AWS D1.1.

User Note: Studs are made from cold drawn bar, either semi-killed or killed aluminum or silicon deoxidized, conforming to the requirements of ASTM A29/A29M-04, Standard Specification for Steel Bars, Carbon and Alloy, Hot-Wrought, General Requirements for.

Manufacturer's certification shall constitute sufficient evidence of conformity with AWS D1.1.

A4. STRUCTURAL DESIGN DRAWINGS AND SPECIFICATIONS

The design drawings and specifications shall meet the requirements in the *Code of Standard Practice for Steel Buildings and Bridges*, except for deviations specifically identified in the design drawings and/or specifications.

CHAPTER B

DESIGN REQUIREMENTS

The general requirements for the analysis and design of steel structures that are applicable to all chapters of the specification are given in this chapter.

The chapter is organized as follows:

- B1. General Provisions
- B2. Loads and Load Combinations
- B3. Design Basis
- B4. Classification of Sections for Local Buckling
- B5. Fabrication, Erection and Quality Control
- B6. Evaluation of Existing Structures

B1. GENERAL PROVISIONS

The design of members and *connections* shall be consistent with the intended behavior of the framing system and the assumptions made in the *structural analysis*. Unless restricted by the *applicable building code*, lateral load resistance and *stability* may be provided by any combination of members and connections.

B2. LOADS AND LOAD COMBINATIONS

The loads and load combinations shall be as stipulated by the *applicable building code*. In the absence of a building code, the loads and load combinations shall be those stipulated in SEI/ASCE 7. For design purposes, the *nominal loads* shall be taken as the *loads* stipulated by the applicable building code.

User Note: For LRFD designs, the load combinations in SEI/ASCE 7, Section 2.3 apply. For ASD designs, the load combinations in SEI/ASCE 7, Section 2.4 apply.

B3. DESIGN BASIS

Designs shall be made according to the provisions for *Load and Resistance Factor Design (LRFD)* or to the provisions for *Allowable Strength Design (ASD)*.

1. Required Strength

The *required strength* of structural members and *connections* shall be determined by *structural analysis* for the appropriate load combinations as stipulated in Section B2.

Design by *elastic, inelastic* or *plastic analysis* is permitted. Provisions for inelastic and plastic analysis are as stipulated in Appendix 1, Inelastic Analysis and Design. The provisions for moment redistribution in continuous beams in Appendix 1, Section 1.3 are permitted for elastic analysis only.

2. Limit States

Design shall be based on the principle that no applicable strength or serviceability *limit state* shall be exceeded when the structure is subjected to all appropriate load combinations.

3. Design for Strength Using Load and Resistance Factor Design (LRFD)

Design according to the provisions for *Load and Resistance Factor Design* (LRFD) satisfies the requirements of this Specification when the *design strength* of each *structural component* equals or exceeds the *required strength* determined on the basis of the *LRFD load combinations*. All provisions of this Specification, except for those in Section B3.4, shall apply.

Design shall be performed in accordance with Equation B3-1:

$$R_u \leq \phi R_n \quad (\text{B3-1})$$

where

R_u = required strength (LRFD)

R_n = *nominal strength*, specified in Chapters B through K

ϕ = *resistance factor*, specified in Chapters B through K

ϕR_n = design strength

4. Design for Strength Using Allowable Strength Design (ASD)

Design according to the provisions for *Allowable Strength Design* (ASD) satisfies the requirements of this Specification when the *allowable strength* of each *structural component* equals or exceeds the *required strength* determined on the basis of the *ASD load combinations*. All provisions of this Specification, except those of Section B3.3, shall apply.

Design shall be performed in accordance with Equation B3-2:

$$R_a \leq R_n / \Omega \quad (\text{B3-2})$$

where

R_a = required strength (ASD)

R_n = *nominal strength*, specified in Chapters B through K

Ω = safety factor, specified in Chapters B through K

R_n / Ω = allowable strength

5. Design for Stability

Stability of the structure and its elements shall be determined in accordance with Chapter C.

6. Design of Connections

Connection elements shall be designed in accordance with the provisions of Chapters J and K. The *forces* and deformations used in design shall be consistent with the intended performance of the connection and the assumptions used in the *structural analysis*.

User Note: Section 3.1.2 of the *Code of Standard Practice* addresses communication of necessary information for the design of connections.

6a. Simple Connections

A simple connection transmits a negligible moment across the connection. In the analysis of the structure, simple connections may be assumed to allow unrestrained relative rotation between the framing elements being connected. A simple connection shall have sufficient rotation capacity to accommodate the required rotation determined by the analysis of the structure. Inelastic rotation of the connection is permitted.

6b. Moment Connections

A moment connection transmits moment across the connection. Two types of moment connections, FR and PR, are permitted, as specified below.

(a) *Fully-Restrained (FR) Moment Connections*

A fully-restrained (FR) moment connection transfers moment with a negligible rotation between the connected members. In the analysis of the structure, the connection may be assumed to allow no relative rotation. An FR connection shall have sufficient strength and stiffness to maintain the angle between the connected members at the strength limit states.

(b) *Partially-Restrained (PR) Moment Connections*

Partially-restrained (PR) moment connections transfer moments, but the rotation between connected members is not negligible. In the analysis of the structure, the force-deformation response characteristics of the connection shall be included. The response characteristics of a PR connection shall be documented in the technical literature or established by analytical or experimental means. The component elements of a PR connection shall have sufficient strength, stiffness, and deformation capacity at the strength limit states.

7. Design for Serviceability

The overall structure and the individual members, *connections*, and connectors shall be checked for serviceability. Performance requirements for serviceability design are given in Chapter L.

8. Design for Ponding

The roof system shall be investigated through *structural analysis* to assure adequate strength and *stability* under *ponding* conditions, unless the roof surface is provided with a slope of $1/4$ in. per ft (20 mm per meter) or greater toward points of free drainage or an adequate system of drainage is provided to prevent the accumulation of water.

See Appendix 2, Design for Ponding, for methods of checking ponding.

9. Design for Fatigue

Fatigue shall be considered in accordance with Appendix 3, Design for Fatigue, for members and their *connections* subject to repeated *loading*. Fatigue need not be considered for seismic effects or for the effects of wind loading on normal building *lateral load resisting systems* and building enclosure components.

10. Design for Fire Conditions

Two methods of design for fire conditions are provided in Appendix 4, Structural Design for Fire Conditions: Qualification Testing and Engineering Analysis. Compliance with the fire protection requirements in the *applicable building code* shall be deemed to satisfy the requirements of this section and Appendix 4.

Nothing in this section is intended to create or imply a contractual requirement for the *engineer of record* responsible for the structural design or any other member of the design team.

User Note: Design by qualification testing is the prescriptive method specified in most building codes. Traditionally, on most projects where the architect is the prime professional, the architect has been the responsible party to specify and coordinate fire protection requirements. Design by Engineering Analysis is a new engineering approach to fire protection. Designation of the person(s) responsible for designing for fire conditions is a contractual matter to be addressed on each project.

11. Design for Corrosion Effects

Where corrosion may impair the strength or serviceability of a structure, *structural components* shall be designed to tolerate corrosion or shall be protected against corrosion.

12. Design Wall Thickness for HSS

The *design wall thickness*, t , shall be used in calculations involving the wall thickness of hollow structural sections (*HSS*). The design wall thickness, t , shall be taken equal to 0.93 times the nominal wall thickness for electric-resistance-welded (ERW) HSS and equal to the nominal thickness for submerged-arc-welded (SAW) HSS.

13. Gross and Net Area Determination

a. Gross Area

The gross area, A_g , of a member is the total cross-sectional area.

b. Net Area

The *net area*, A_n , of a member is the sum of the products of the thickness and the net width of each element computed as follows:

In computing net area for tension and shear, the width of a bolt hole shall be taken as $1/16$ in. (2 mm) greater than the *nominal dimension* of the hole.

For a chain of holes extending across a part in any diagonal or zigzag line, the net width of the part shall be obtained by deducting from the gross width the sum of the diameters or slot dimensions as provided in Section J3.2, of all holes in the chain, and adding, for each *gage* space in the chain, the quantity $s^2/4g$

where

s = longitudinal center-to-center spacing (*pitch*) of any two consecutive holes, in. (mm)

g = transverse center-to-center spacing (*gage*) between *fastener* gage lines, in. (mm)

For angles, the gage for holes in opposite adjacent legs shall be the sum of the gages from the back of the angles less the thickness.

For slotted *HSS* welded to a *gusset plate*, the net area, A_n , is the gross area minus the product of the thickness and the total width of material that is removed to form the slot.

In determining the net area across plug or *slot welds*, the *weld metal* shall not be considered as adding to the net area.

User Note: Section J4.1(b) limits A_n to a maximum of $0.85A_g$ for splice plates with holes.

B4. CLASSIFICATION OF SECTIONS FOR LOCAL BUCKLING

Sections are classified as *compact*, *noncompact*, or *slender-element sections*. For a section to qualify as compact its flanges must be continuously connected to the web or webs and the width-thickness ratios of its compression elements must not exceed the limiting width-thickness ratios λ_p from Table B4.1. If the width-thickness ratio of one or more compression elements exceeds λ_p , but does not exceed λ_r from Table B4.1, the section is noncompact. If the width-thickness ratio of any element exceeds λ_r , the section is referred to as a *slender-element section*.

1. Unstiffened Elements

For *unstiffened elements* supported along only one edge parallel to the direction of the compression *force*, the width shall be taken as follows:

- (a) For flanges of I-shaped members and tees, the width b is one-half the full-flange width, b_f .
- (b) For legs of angles and flanges of channels and zees, the width b is the full *nominal dimension*.
- (c) For plates, the width b is the distance from the free edge to the first row of *fasteners* or line of welds.
- (d) For stems of tees, d is taken as the full nominal depth of the section.

User Note: Refer to Table B4.1 for the graphic representation of unstiffened element dimensions.

2. Stiffened Elements

For *stiffened elements* supported along two edges parallel to the direction of the compression *force*, the width shall be taken as follows:

- (a) For webs of rolled or *formed sections*, h is the clear distance between flanges less the fillet or corner radius at each flange; h_c is twice the distance from the centroid to the inside face of the compression flange less the fillet or corner radius.
- (b) For webs of built-up sections, h is the distance between adjacent lines of *fasteners* or the clear distance between flanges when welds are used, and h_c is twice the distance from the centroid to the nearest line of fasteners at the compression flange or the inside face of the compression flange when welds are used; h_p is twice the distance from the plastic neutral axis to the nearest line of fasteners at the compression flange or the inside face of the compression flange when welds are used.
- (c) For flange or *diaphragm plates* in built-up sections, the width b is the distance between adjacent lines of fasteners or lines of welds.
- (d) For flanges of rectangular hollow structural sections (*HSS*), the width b is the clear distance between webs less the inside corner radius on each side. For webs of rectangular HSS, h is the clear distance between the flanges less the inside corner radius on each side. If the corner radius is not known, b and h shall be taken as the corresponding outside dimension minus three times the thickness. The thickness, t , shall be taken as the *design wall thickness*, per Section B3.12.

User Note: Refer to Table B4.1 for the graphic representation of stiffened element dimensions.

For tapered flanges of rolled sections, the thickness is the nominal value halfway between the free edge and the corresponding face of the web.

TABLE B4.1
Limiting Width-Thickness Ratios for
Compression Elements



Case	Description of Element	Width Thickness Ratio	Limiting Width-Thickness Ratios		Example	
			λ_p (compact)	λ_r (noncompact)		
Unstiffened Elements	1	Flexure in flanges of rolled I-shaped sections and channels	b/t	$0.38\sqrt{E/F_y}$	$1.0\sqrt{E/F_y}$	
	2	Flexure in flanges of doubly and singly symmetric I-shaped built-up sections	b/t	$0.38\sqrt{E/F_y}$	$0.95\sqrt{k_c E/F_L}^{[a],[b]}$	
	3	Uniform compression in flanges of rolled I-shaped sections, plates projecting from rolled I-shaped sections; outstanding legs of pairs of angles in continuous contact and flanges of channels	b/t	NA	$0.56\sqrt{E/F_y}$	
	4	Uniform compression in flanges of built-up I-shaped sections and plates or angle legs projecting from built-up I-shaped sections	b/t	NA	$0.64\sqrt{k_c E/F_y}^{[a]}$	
	5	Uniform compression in legs of single angles, legs of double angles with separators, and all other unstiffened elements	b/t	NA	$0.45\sqrt{E/F_y}$	
	6	Flexure in legs of single angles	b/t	$0.54\sqrt{E/F_y}$	$0.91\sqrt{E/F_y}$	

TABLE B4.1 (cont.)
Limiting Width-Thickness Ratios for
Compression Elements

Case	Description of Element	Width Thickness Ratio	Limiting Width-Thickness Ratios		Example	
			λ_p (compact)	λ_r (noncompact)		
7	Flexure in flanges of tees	b/t	$0.38\sqrt{E/F_y}$	$1.0\sqrt{E/F_y}$		
8	Uniform compression in stems of tees	d/t	NA	$0.75\sqrt{E/F_y}$		
Stiffened Elements	9	Flexure in webs of doubly symmetric I-shaped sections and channels	h/t_w	$3.76\sqrt{E/F_y}$	$5.70\sqrt{E/F_y}$	
	10	Uniform compression in webs of doubly symmetric I-shaped sections	h/t_w	NA	$1.49\sqrt{E/F_y}$	
	11	Flexure in webs of singly-symmetric I-shaped sections	h_c/t_w	$\frac{\frac{h_c}{h_p}\sqrt{\frac{E}{F_y}}}{\left(0.54\frac{M_p}{M_y} - 0.09\right)^2} \leq \lambda_r$	$5.70\sqrt{E/F_y}$	
	12	Uniform compression in flanges of rectangular box and hollow structural sections of uniform thickness subject to bending or compression; flange cover plates and diaphragm plates between lines of fasteners or welds	b/t	$1.12\sqrt{E/F_y}$	$1.40\sqrt{E/F_y}$	
	13	Flexure in webs of rectangular HSS	h/t	$2.42\sqrt{E/F_y}$	$5.70\sqrt{E/F_y}$	

TABLE B4.1 (cont.)
Limiting Width-Thickness Ratios for
Compression Elements

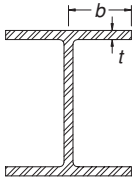
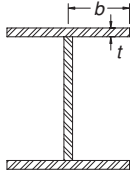
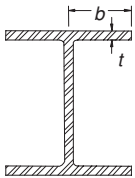
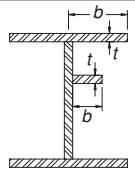
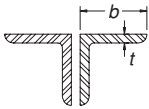
Case	Description of Element	Width Thickness Ratio	Limiting Width-Thickness Ratios		Example
			λ_p (compact)	λ_r (noncompact)	
14	Uniform compression in all other stiffened elements	b/t	NA	$1.49\sqrt{E/F_y}$	
15	Circular hollow sections				
	In uniform compression	D/t	NA	$0.11 E/F_y$	
	In flexure	D/t	$0.07 E/F_y$	$0.31 E/F_y$	

[a] $k_c = \frac{4}{\sqrt{h/t_w}}$, but shall not be taken less than 0.35 nor greater than 0.76 for calculation purposes. (See Cases 2 and 4)

[b] $F_L = 0.7F_y$ for minor-axis bending, major axis bending of slender-web built-up I-shaped members, and major axis bending of compact and noncompact web built-up I-shaped members with $S_{xt}/S_{xc} \geq 0.7$; $F_L = F_y S_{xt}/S_{xc} \geq 0.5F_y$ for major-axis bending of compact and noncompact web built-up I-shaped members with $S_{xt}/S_{xc} < 0.7$. (See Case 2)

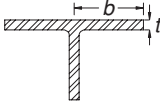
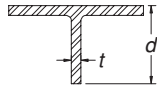
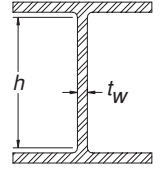
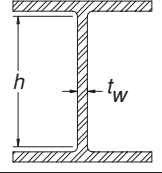
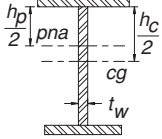
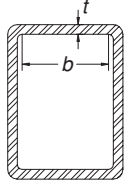
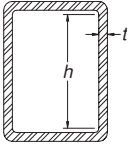
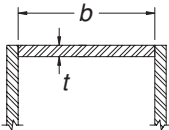
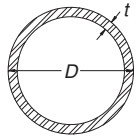
B5. FABRICATION, ERECTION AND QUALITY CONTROL

Shop drawings, fabrication, shop painting, erection, and *quality control* shall meet the requirements stipulated in Chapter M, Fabrication, Erection, and Quality Control.

B6. EVALUATION OF EXISTING STRUCTURES

Provisions for the evaluation of existing structures are presented in Appendix 5, Evaluation of Existing Structures.

CHAPTER C

STABILITY ANALYSIS AND DESIGN

This chapter addresses general requirements for the stability analysis and design of members and frames.

The chapter is organized as follows:

- C1. Stability Design Requirements
- C2. Calculation of Required Strengths

C1. STABILITY DESIGN REQUIREMENTS

1. General Requirements

Stability shall be provided for the structure as a whole and for each of its elements. Any method that considers the influence of *second-order effects* (including P - Δ and P - δ effects), flexural, shear and axial deformations, geometric imperfections, and member stiffness reduction due to residual stresses on the stability of the structure and its elements is permitted. The methods prescribed in this chapter and Appendix 7, Direct Analysis Method, satisfy these requirements. All component and *connection* deformations that contribute to the lateral displacements shall be considered in the stability analysis.

In structures designed by elastic analysis, individual member stability and stability of the structure as a whole are provided jointly by:

- (1) Calculation of the *required strengths* for members, connections and other elements using one of the methods specified in Section C2.2, and
- (2) Satisfaction of the member and connection design requirements in this specification based upon those required strengths.

In structures designed by inelastic analysis, the provisions of Appendix 1, Inelastic Analysis and Design, shall be satisfied.

2. Member Stability Design Requirements

Individual member stability is provided by satisfying the provisions of Chapters E, F, G, H and I.

User Note: Local buckling of cross section components can be avoided by the use of compact sections defined in Section B4.

Where elements are designed to function as braces to define the unbraced length of columns and beams, the bracing system shall have sufficient stiffness and strength to control member movement at the braced points. Methods of satisfying

this requirement are provided in Appendix 6, Stability Bracing for Columns and Beams.

3. System Stability Design Requirements

Lateral stability shall be provided by *moment frames, braced frames, shear walls, and/or other equivalent lateral load resisting systems*. The overturning effects of *drift* and the destabilizing influence of *gravity loads* shall be considered. *Force transfer and load sharing* between elements of the framing systems shall be considered. Braced-frame and shear-wall systems, moment frames, gravity framing systems, and *combined systems* shall satisfy the following specific requirements:

3a. Braced-Frame and Shear-Wall Systems

In structures where lateral stability is provided solely by diagonal bracing, shear walls, or equivalent means, the *effective length factor, K* , for compression members shall be taken as 1.0, unless *structural analysis* indicates that a smaller value is appropriate. In braced-frame systems, it is permitted to design the columns, beams, and diagonal members as a vertically cantilevered, simply connected truss.

User Note: Knee-braced frames function as moment-frame systems and should be treated as indicated in Section C1.3b. Eccentrically braced frame systems function as combined systems and should be treated as indicated in Section C1.3d.

3b. Moment-Frame Systems

In frames where lateral stability is provided by the flexural stiffness of connected beams and columns, the effective length factor K or elastic critical buckling stress, F_e , for *columns* and *beam-columns* shall be determined as specified in Section C2.

3c. Gravity Framing Systems

Columns in gravity framing systems shall be designed based on their actual length ($K = 1.0$) unless analysis shows that a smaller value may be used. The lateral stability of gravity framing systems shall be provided by moment frames, braced frames, shear walls, and/or other equivalent lateral load resisting systems. P - Δ effects due to load on the gravity columns shall be transferred to the lateral load resisting systems and shall be considered in the calculation of the required strengths of the lateral load resisting systems.

3d. Combined Systems

The analysis and design of members, *connections* and other elements in combined systems of moment frames, braced frames, and/or shear walls and gravity frames shall meet the requirements of their respective systems.

C2. CALCULATION OF REQUIRED STRENGTHS

Except as permitted in Section C2.2b, *required strengths* shall be determined using a *second-order analysis* as specified in Section C2.1. Design by either second-order or *first-order analysis* shall meet the requirements specified in Section C2.2.

1. Methods of Second-Order Analysis

Second-order analysis shall conform to the requirements in this Section.

1a. General Second-Order Elastic Analysis

Any second-order elastic analysis method that considers both P - Δ and P - δ effects may be used.

The Amplified First-Order Elastic Analysis Method defined in Section C2.1b is an accepted method for second-order elastic analysis of braced, moment, and combined framing systems.

1b. Second-Order Analysis by Amplified First-Order Elastic Analysis

User Note: A method is provided in this section to account for second-order effects in frames by amplifying the axial forces and moments in members and connections from a first-order analysis.

The following is an approximate second-order analysis procedure for calculating the required flexural and axial strengths in members of *lateral load resisting systems*. The required second-order flexural strength, M_r , and axial strength, P_r , shall be determined as follows:

$$M_r = B_1 M_{nt} + B_2 M_{lt} \quad (C2-1a)$$

$$P_r = P_{nt} + B_2 P_{lt} \quad (C2-1b)$$

where

$$B_1 = \frac{C_m}{1 - \alpha P_r / P_{e1}} \geq 1 \quad (C2-2)$$

For members subjected to axial compression, B_1 may be calculated based on the first-order estimate $P_r = P_{nt} + P_{lt}$.

User Note: B_1 is an amplifier to account for second order effects caused by displacements between brace points (P - δ) and B_2 is an amplifier to account for second order effects caused by displacements of braced points (P - Δ).

For members in which $B_1 \leq 1.05$, it is conservative to amplify the sum of the non-sway and sway moments (as obtained, for instance, by a first-order elastic analysis) by the B_2 amplifier, in other words, $M_r = B_2(M_{nt} + M_{lt})$.

$$B_2 = \frac{1}{1 - \frac{\alpha \Sigma P_{nt}}{\Sigma P_{e2}}} \geq 1 \quad (C2-3)$$

User Note: Note that the B_2 amplifier (Equation C2-3) can be estimated in preliminary design by using a maximum lateral drift limit corresponding to the story shear ΣH in Equation C2-6b.

and

$$\alpha = 1.00 \text{ (LRFD)} \quad \alpha = 1.60 \text{ (ASD)}$$

- M_r = required second-order flexural strength using LRFD or ASD load combinations, kip-in. (N-mm)
- M_{nt} = first-order moment using LRFD or ASD load combinations, assuming there is no lateral translation of the frame, kip-in. (N-mm)
- M_{lt} = first-order moment using LRFD or ASD load combinations caused by lateral translation of the frame only, kip-in. (N-mm)
- P_r = required second-order axial strength using LRFD or ASD load combinations, kips (N)
- P_{nt} = first-order axial force using LRFD or ASD load combinations, assuming there is no lateral translation of the frame, kips (N)
- ΣP_{nt} = total vertical load supported by the story using LRFD or ASD load combinations, including gravity column loads, kips (N)
- P_{lt} = first-order axial force using LRFD or ASD load combinations caused by lateral translation of the frame only, kips (N)
- C_m = a coefficient assuming no lateral translation of the frame whose value shall be taken as follows:

- (i) For beam-columns not subject to transverse loading between supports in the plane of bending,

$$C_m = 0.6 - 0.4(M_1/M_2) \quad (C2-4)$$

where M_1 and M_2 , calculated from a first-order analysis, are the smaller and larger moments, respectively, at the ends of that portion of the member unbraced in the plane of bending under consideration. M_1/M_2 is positive when the member is bent in reverse curvature, negative when bent in single curvature.

- (ii) For beam-columns subjected to transverse loading between supports, the value of C_m shall be determined either by analysis or conservatively taken as 1.0 for all cases.

- P_{e1} = elastic critical buckling resistance of the member in the plane of bending, calculated based on the assumption of zero sidesway, kips (N)

$$P_{e1} = \frac{\pi^2 EI}{(K_1 L)^2} \quad (C2-5)$$

- ΣP_{e2} = elastic critical buckling resistance for the story determined by sidesway buckling analysis, kips (N)

For moment frames, where sidesway buckling effective length factors K_2 are determined for the columns, it is permitted to calculate the elastic story sidesway buckling resistance as

$$\Sigma P_{e2} = \Sigma \frac{\pi^2 EI}{(K_2 L)^2} \quad (C2-6a)$$

For all types of lateral load resisting systems, it is permitted to use

$$\Sigma P_{e2} = R_M \frac{\Sigma HL}{\Delta_H} \quad (C2-6b)$$

where

E = modulus of elasticity of steel = 29,000 ksi (200 000 MPa)

R_M = 1.0 for braced-frame systems;

= 0.85 for moment-frame and combined systems, unless a larger value is justified by analysis

I = moment of inertia in the plane of bending, in.⁴ (mm⁴)

L = story height, in. (mm)

K_1 = effective length factor in the plane of bending, calculated based on the assumption of no lateral translation, set equal to 1.0 unless analysis indicates that a smaller value may be used

K_2 = effective length factor in the plane of bending, calculated based on a sidesway buckling analysis

User Note: Methods for calculation of K_2 are discussed in the Commentary.

Δ_H = first-order interstory drift due to lateral forces, in. (mm). Where Δ_H varies over the plan area of the structure, Δ_H shall be the average drift weighted in proportion to vertical load or, alternatively, the maximum drift.

ΣH = story shear produced by the lateral forces used to compute Δ_H , kips (N)

2. Design Requirements

These requirements apply to all types of braced, moment, and combined framing systems. Where the ratio of second-order drift to first-order drift is equal to or less than 1.5, the *required strengths* of members, *connections* and other elements shall be determined by one of the methods specified in Sections C2.2a or C2.2b, or by the *Direct Analysis Method* of Appendix 7. Where the ratio of second-order drift to first-order drift is greater than 1.5, the required strengths shall be determined by the Direct Analysis Method of Appendix 7.

User Note: The ratio of second-order drift to first-order drift can be represented by B_2 , as calculated using Equation C2-3. Alternatively, the ratio can be calculated by comparing the results of a second-order analysis to the results of a first-order analysis, where the analyses are conducted either under LRFD load combinations directly or under ASD load combinations with a 1.6 factor applied to the ASD gravity loads.

For the methods specified in Sections 2.2a or 2.2b:

- (1) Analyses shall be conducted according to the design and loading requirements specified in either Section B3.3 (LRFD) or Section B3.4 (ASD).
- (2) The structure shall be analyzed using the nominal geometry and the nominal elastic stiffness for all elements.

2a. Design by Second-Order Analysis

Where required strengths are determined by a *second-order analysis*:

- (1) The provisions of Section C2.1 shall be satisfied.

- (2) For design by ASD, analyses shall be carried out under 1.6 times the *ASD load combinations* and the results shall be divided by 1.6 to obtain the required strengths.

User Note: The amplified first order analysis method of Section C2.1b incorporates the 1.6 multiplier directly in the B_1 and B_2 amplifiers, such that no other modification is needed.

- (3) All gravity-only load combinations shall include a minimum lateral load applied at each level of the structure of $0.002Y_i$, where Y_i is the *design gravity load* applied at level i , kips (N). This minimum *lateral load* shall be considered independently in two orthogonal directions.

User Note: The minimum lateral load of $0.002Y_i$, in conjunction with the other design-analysis constraints listed in this section, limits the error that would otherwise be caused by neglecting initial out-of-plumbness and member stiffness reduction due to residual stresses in the analysis.

- (4) Where the ratio of second-order drift to first-order drift is less than or equal to 1.1, members are permitted to be designed using $K = 1.0$. Otherwise, *columns* and *beam-columns* in *moment frames* shall be designed using a K factor or column buckling stress, F_e , determined from a sidesway buckling analysis of the structure. Stiffness reduction adjustment due to column inelasticity is permitted in the determination of the K factor. For *braced frames*, K for compression members shall be taken as 1.0, unless structural analysis indicates a smaller value may be used.

2b. Design by First-Order Analysis

Required strengths are permitted to be determined by a first-order analysis, with all members designed using $K = 1.0$, provided that

- (1) The required compressive strengths of all members whose flexural stiffnesses are considered to contribute to the lateral stability of the structure satisfy the following limitation:

$$\alpha P_r \leq 0.5 P_y \quad (\text{C2-7})$$

where

$$\alpha = 1.0 \text{ (LRFD)} \quad \alpha = 1.6 \text{ (ASD)}$$

P_r = required axial compressive strength under LRFD or ASD load combinations, kips (N)

P_y = member yield strength ($= AF_y$), kips (N)

- (2) All load combinations include an additional lateral load, N_i , applied in combination with other loads at each level of the structure, where

$$N_i = 2.1(\Delta/L)Y_i \geq 0.0042Y_i \quad (\text{C2-8})$$

Y_i = gravity load from the LRFD load combination or 1.6 times the ASD load combination applied at level i , kips (N)

Δ/L = the maximum ratio of Δ to L for all stories in the structure

Δ = first-order interstory drift due to the design loads, in. (mm). Where Δ varies over the plan area of the structure, Δ shall be the average drift weighted in proportion to vertical load or, alternatively, the maximum drift.

L = story height, in. (mm)

User Note: The drift Δ is calculated under LRFD load combinations directly or under ASD load combinations with a 1.6 factor applied to the ASD gravity loads.

This additional lateral load shall be considered independently in two orthogonal directions.

(3) The non-sway amplification of beam-column moments is considered by applying the B_1 amplifier of Section C2.1 to the total member moments.

CHAPTER D

DESIGN OF MEMBERS FOR TENSION

This chapter applies to members subject to axial tension caused by static *forces* acting through the centroidal axis.

The chapter is organized as follows:

- D1. Slenderness Limitations
- D2. Tensile Strength
- D3. Area Determination
- D4. Built-Up Members
- D5. Pin-Connected Members
- D6. Eyebars

User Note: For cases not included in this chapter the following sections apply:

- B3.9 Members subject to fatigue.
- Chapter H Members subject to combined axial tension and flexure.
- J3. Threaded rods.
- J4.1 Connecting elements in tension.
- J4.3 Block shear rupture strength at end connections of tension members.

D1. SLENDERNESS LIMITATIONS

There is no maximum slenderness limit for design of members in tension.

User Note: For members designed on the basis of tension, the slenderness ratio L/r preferably should not exceed 300. This suggestion does not apply to rods or hangers in tension.

D2. TENSILE STRENGTH

The *design tensile strength*, $\phi_t P_n$, and the *allowable tensile strength*, P_n/Ω_t , of tension members, shall be the lower value obtained according to the *limit states of tensile yielding* in the gross section and *tensile rupture* in the net section.

(a) For tensile yielding in the gross section:

$$P_n = F_y A_g \quad (D2-1)$$

$$\phi_t = 0.90 \text{ (LRFD)} \quad \Omega_t = 1.67 \text{ (ASD)}$$

(b) For tensile rupture in the net section:

$$P_n = F_u A_e \quad (D2-2)$$

$$\phi_t = 0.75 \text{ (LRFD)} \quad \Omega_t = 2.00 \text{ (ASD)}$$

where

A_e = effective net area, in.² (mm²)

A_g = gross area of member, in.² (mm²)

F_y = specified minimum yield stress of the type of steel being used, ksi (MPa)

F_u = specified minimum tensile strength of the type of steel being used, ksi (MPa)

When members without holes are fully connected by welds, the effective net area used in Equation D2-2 shall be as defined in Section D3. When holes are present in a member with welded end *connections*, or at the welded connection in the case of plug or *slot welds*, the effective net area through the holes shall be used in Equation D2-2.

D3. AREA DETERMINATION

1. Gross Area

The gross area, A_g , of a member is the total cross-sectional area.

2. Net Area

The *net area*, A_n , of a member is the sum of the products of the thickness and the net width of each element computed as follows:

In computing net area for tension and shear, the width of a bolt hole shall be taken as $1/16$ in. (2 mm) greater than the *nominal dimension* of the hole.

For a chain of holes extending across a part in any diagonal or zigzag line, the net width of the part shall be obtained by deducting from the gross width the sum of the diameters or slot dimensions as provided in Section J3.2, of all holes in the chain, and adding, for each *gage* space in the chain, the quantity $s^2/4g$

where

s = longitudinal center-to-center spacing (*pitch*) of any two consecutive holes, in. (mm)

g = transverse center-to-center spacing (*gage*) between *fastener* gage lines, in. (mm)

For angles, the gage for holes in opposite adjacent legs shall be the sum of the gages from the back of the angles less the thickness.

For slotted *HSS* welded to a *gusset plate*, the net area, A_n , is the gross area minus the product of the thickness and the total width of material that is removed to form the slot.

In determining the net area across plug or *slot welds*, the *weld metal* shall not be considered as adding to the net area.

User Note: Section J4.1(b) limits A_n to a maximum of $0.85A_g$ for splice plates with holes.

3. Effective Net Area

The effective area of tension members shall be determined as follows:

$$A_e = A_n U \quad (\text{D3-1})$$

where U , the shear lag factor, is determined as shown in Table D3.1.

Members such as single angles, double angles and WT sections shall have *connections* proportioned such that U is equal to or greater than 0.60. Alternatively, a lesser value of U is permitted if these tension members are designed for the effect of eccentricity in accordance with H1.2 or H2.

D4. BUILT-UP MEMBERS

For limitations on the longitudinal spacing of connectors between elements in continuous contact consisting of a plate and a shape or two plates, see Section J3.5.

Either perforated *cover plates* or *tie plates* without *lacing* are permitted to be used on the open sides of built-up tension members. Tie plates shall have a length not less than two-thirds the distance between the lines of welds or *fasteners* connecting them to the components of the member. The thickness of such tie plates shall not be less than one-fiftieth of the distance between these lines. The longitudinal spacing of intermittent welds or fasteners at tie plates shall not exceed 6 in. (150 mm).

User Note: The longitudinal spacing of connectors between components should preferably limit the slenderness ratio in any component between the connectors to 300.

D5. PIN-CONNECTED MEMBERS

1. Tensile Strength

The *design tensile strength*, $\phi_t P_n$, and the *allowable tensile strength*, P_n / Ω_t , of pin-connected members, shall be the lower value obtained according to the *limit states* of *tensile rupture*, *shear rupture*, *bearing*, and *yielding*.

(a) For tensile rupture on the net effective area:

$$P_n = 2tb_{\text{eff}}F_u \quad (\text{D5-1})$$

$$\phi_t = 0.75 \text{ (LRFD)} \quad \Omega_t = 2.00 \text{ (ASD)}$$

TABLE D3.1
Shear Lag Factors for Connections to Tension Members

Case	Description of Element		Shear Lag Factor, U	Example
1	All tension members where the tension load is transmitted directly to each of cross-sectional elements by fasteners or welds. (except as in Cases 3, 4, 5 and 6)		$U = 1.0$	—
2	All tension members, except plates and HSS, where the tension load is transmitted to some but not all of the cross-sectional elements by fasteners or longitudinal welds (Alternatively, for W, M, S and HP, Case 7 may be used.)		$U = 1 - \bar{x}/l$	
3	All tension members where the tension load is transmitted by transverse welds to some but not all of the cross-sectional elements.		$U = 1.0$ and $A_n =$ area of the directly connected elements	—
4	Plates where the tension load is transmitted by longitudinal welds only.		$l \geq 2w \dots U = 1.0$ $2w > l \geq 1.5w \dots U = 0.87$ $1.5w > l \geq w \dots U = 0.75$	
5	Round HSS with a single concentric gusset plate		$l \geq 1.3D \dots U = 1.0$ $D \leq l < 1.3D \dots U = 1 - \bar{x}/l$ $\bar{x} = D/\pi$	
6	Rectangular HSS	with a single concentric gusset plate	$l \geq H \dots U = 1 - \bar{x}/l$ $\bar{x} = \frac{B^2 + 2BH}{4(B + H)}$	
		with two side gusset plates	$l \geq H \dots U = 1 - \bar{x}/l$ $\bar{x} = \frac{B^2}{4(B + H)}$	
7	W, M, S or HP Shapes or Tees cut from these shapes. (If U is calculated per Case 2, the larger value is permitted to be used)	with flange connected with 3 or more fasteners per line in direction of loading	$b_f \geq 2/3d \dots U = 0.90$ $b_f < 2/3d \dots U = 0.85$	—
		with web connected with 4 or more fasteners in the direction of loading	$U = 0.70$	—
8	Single angles (If U is calculated per Case 2, the larger value is permitted to be used)	with 4 or more fasteners per line in direction of loading	$U = 0.80$	—
		with 2 or 3 fasteners per line in the direction of loading	$U = 0.60$	—

l = length of connection, in. (mm); w = plate width, in. (mm); \bar{x} = connection eccentricity, in. (mm); B = overall width of rectangular HSS member, measured 90 degrees to the plane of the connection, in. (mm); H = overall height of rectangular HSS member, measured in the plane of the connection, in. (mm)

(b) For shear rupture on the effective area:

$$P_n = 0.6F_u A_{sf} \quad (\text{D5-2})$$

$$\phi_{sf} = 0.75 \text{ (LRFD)} \quad \Omega_{sf} = 2.00 \text{ (ASD)}$$

where

$$A_{sf} = 2t(a + d/2), \text{ in.}^2(\text{mm}^2)$$

a = shortest distance from edge of the pin hole to the edge of the member measured parallel to the direction of the *force*, in. (mm)

$b_{eff} = 2t + 0.63$, in. (= $2t + 16$, mm) but not more than the actual distance from the edge of the hole to the edge of the part measured in the direction normal to the applied force

d = pin diameter, in. (mm)

t = thickness of plate, in. (mm)

(c) For bearing on the projected area of the pin, see Section J7.

(d) For yielding on the gross section, use Equation D2-1.

2. Dimensional Requirements

The pin hole shall be located midway between the edges of the member in the direction normal to the applied *force*. When the pin is expected to provide for relative movement between connected parts while under full *load*, the diameter of the pin hole shall not be more than $1/32$ in. (1 mm) greater than the diameter of the pin.

The width of the plate at the pin hole shall not be less than $2b_{eff} + d$ and the minimum extension, a , beyond the bearing end of the pin hole, parallel to the axis of the member, shall not be less than $1.33 \times b_{eff}$.

The corners beyond the pin hole are permitted to be cut at 45° to the axis of the member, provided the *net area* beyond the pin hole, on a plane perpendicular to the cut, is not less than that required beyond the pin hole parallel to the axis of the member.

D6. EYEBARS

1. Tensile Strength

The *available tensile strength* of *eyebars* shall be determined in accordance with Section D2, with A_g taken as the cross-sectional area of the body.

For calculation purposes, the width of the body of the *eyebars* shall not exceed eight times its thickness.

2. Dimensional Requirements

Eyebars shall be of uniform thickness, without reinforcement at the pin holes, and have circular heads with the periphery concentric with the pin hole.

The radius of transition between the circular head and the eyebar body shall not be less than the head diameter.

The pin diameter shall not be less than seven-eighths times the eyebar body width, and the pin hole diameter shall not be more than $1/32$ in. (1 mm) greater than the pin diameter.

For steels having F_y greater than 70 ksi (485 MPa), the hole diameter shall not exceed five times the plate thickness, and the width of the eyebar body shall be reduced accordingly.

A thickness of less than $1/2$ in. (13 mm) is permissible only if external nuts are provided to tighten pin plates and *filler* plates into snug contact. The width from the hole edge to the plate edge perpendicular to the direction of applied *load* shall be greater than two-thirds and, for the purpose of calculation, not more than three-fourths times the eyebar body width.

CHAPTER E

DESIGN OF MEMBERS FOR COMPRESSION

This chapter addresses members subject to axial compression through the centroidal axis.

The chapter is organized as follows:

- E1. General Provisions
- E2. Slenderness Limitations and Effective Length
- E3. Compressive Strength for Flexural Buckling of Members without Slender Elements
- E4. Compressive Strength for Torsional and Flexural-Torsional Buckling of Members without Slender Elements
- E5. Single Angle Compression Members
- E6. Built-Up Members
- E7. Members with Slender Elements

User Note: For members not included in this chapter the following sections apply:

- H1. – H3. Members subject to combined axial compression and flexure.
- H4. Members subject to axial compression and torsion.
- J4.4 Compressive strength of connecting elements.
- I2. Composite axial members.

E1. GENERAL PROVISIONS

The *design compressive strength*, $\phi_c P_n$, and the *allowable compressive strength*, P_n/Ω_c , are determined as follows:

The *nominal compressive strength*, P_n , shall be the lowest value obtained according to the *limit states* of *flexural buckling*, *torsional buckling* and *flexural-torsional buckling*.

- (a) For doubly symmetric and singly symmetric members the limit state of flexural buckling is applicable.
- (b) For singly symmetric and unsymmetric members, and certain doubly symmetric members, such as cruciform or built-up *columns*, the limit states of torsional or flexural-torsional buckling are also applicable.

$$\phi_c = 0.90 \text{ (LRFD)} \quad \Omega_c = 1.67 \text{ (ASD)}$$

E2. SLENDERNESS LIMITATIONS AND EFFECTIVE LENGTH

The effective length factor, K , for calculation of column slenderness, KL/r , shall be determined in accordance with Chapter C,

where

L = laterally unbraced length of the member, in. (mm)

r = governing radius of gyration, in. (mm)

K = the *effective length factor* determined in accordance with Section C2

User Note: For members designed on the basis of compression, the slenderness ratio KL/r preferably should not exceed 200.

E3. COMPRESSIVE STRENGTH FOR FLEXURAL BUCKLING OF MEMBERS WITHOUT SLENDER ELEMENTS

This section applies to compression members with *compact* and *noncompact sections*, as defined in Section B4, for uniformly compressed elements.

User Note: When the torsional unbraced length is larger than the lateral unbraced length, this section may control the design of wide flange and similarly shaped columns.

The *nominal compressive strength*, P_n , shall be determined based on the *limit state of flexural buckling*.

$$P_n = F_{cr} A_g \quad (\text{E3-1})$$

The *flexural buckling stress*, F_{cr} , is determined as follows:

$$(a) \text{ When } \frac{KL}{r} \leq 4.71 \sqrt{\frac{E}{F_y}} \quad (\text{or } F_e \geq 0.44F_y)$$

$$F_{cr} = \left[0.658 \frac{F_y}{F_e} \right] F_y \quad (\text{E3-2})$$

$$(b) \text{ When } \frac{KL}{r} > 4.71 \sqrt{\frac{E}{F_y}} \quad (\text{or } F_e < 0.44F_y)$$

$$F_{cr} = 0.877 F_e \quad (\text{E3-3})$$

where

F_e = elastic critical buckling stress determined according to Equation E3-4, Section E4, or the provisions of Section C2, as applicable, ksi (MPa)

$$F_e = \frac{\pi^2 E}{\left(\frac{KL}{r} \right)^2} \quad (\text{E3-4})$$

User Note: The two equations for calculating the limits and applicability of Sections E3(a) and E3(b), one based on KL/r and one based on F_e , provide the same result.

E4. COMPRESSIVE STRENGTH FOR TORSIONAL AND FLEXURAL-TORSIONAL BUCKLING OF MEMBERS WITHOUT SLENDER ELEMENTS

This section applies to singly symmetric and unsymmetric members, and certain doubly symmetric members, such as cruciform or built-up *columns* with *compact* and *noncompact sections*, as defined in Section B4 for uniformly compressed elements. These provisions are not required for single angles, which are covered in Section E5.

The *nominal compressive strength*, P_n , shall be determined based on the *limit states* of *flexural-torsional* and *torsional buckling*, as follows:

$$P_n = F_{cr} A_g \quad (\text{E4-1})$$

(a) For double-angle and tee-shaped compression members:

$$F_{cr} = \left(\frac{F_{cry} + F_{crz}}{2H} \right) \left[1 - \sqrt{1 - \frac{4F_{cry}F_{crz}H}{(F_{cry} + F_{crz})^2}} \right] \quad (\text{E4-2})$$

where F_{cry} is taken as F_{cr} from Equation E3-2 or E3-3, for *flexural buckling* about the y-axis of symmetry and $\frac{KL}{r} = \frac{KL}{r_y}$, and

$$F_{crz} = \frac{GJ}{A_g \bar{r}_o^2} \quad (\text{E4-3})$$

(b) For all other cases, F_{cr} shall be determined according to Equation E3-2 or E3-3, using the torsional or flexural-torsional elastic buckling *stress*, F_e , determined as follows:

(i) For doubly symmetric members:

$$F_e = \left[\frac{\pi^2 EC_w}{(K_z L)^2} + GJ \right] \frac{1}{I_x + I_y} \quad (\text{E4-4})$$

(ii) For singly symmetric members where y is the axis of symmetry:

$$F_e = \left(\frac{F_{ey} + F_{ez}}{2H} \right) \left[1 - \sqrt{1 - \frac{4F_{ey}F_{ez}H}{(F_{ey} + F_{ez})^2}} \right] \quad (\text{E4-5})$$

(iii) For unsymmetric members, F_e is the lowest root of the cubic equation:

$$\begin{aligned} (F_e - F_{ex})(F_e - F_{ey})(F_e - F_{ez}) - F_e^2(F_e - F_{ey}) \left(\frac{x_o}{\bar{r}_o} \right)^2 \\ - F_e^2(F_e - F_{ex}) \left(\frac{y_o}{\bar{r}_o} \right)^2 = 0 \end{aligned} \quad (\text{E4-6})$$

where

A_g = gross area of member, in.² (mm²)

C_w = warping constant, in.⁶ (mm⁶)

$$\bar{r}_o^2 = x_o^2 + y_o^2 + \frac{I_x + I_y}{A_g} \quad (\text{E4-7})$$

$$H = 1 - \frac{x_o^2 + y_o^2}{\bar{r}_o^2} \quad (\text{E4-8})$$

$$F_{ex} = \frac{\pi^2 E}{\left(\frac{K_x L}{r_x}\right)^2} \quad (\text{E4-9})$$

$$F_{ey} = \frac{\pi^2 E}{\left(\frac{K_y L}{r_y}\right)^2} \quad (\text{E4-10})$$

$$F_{ez} = \left(\frac{\pi^2 E C_w}{(K_z L)^2} + GJ\right) \frac{1}{A_g \bar{r}_o^2} \quad (\text{E4-11})$$

G = shear modulus of elasticity of steel = 11,200 ksi
(77 200 MPa)

I_x, I_y = moment of inertia about the principal axes, in.⁴ (mm⁴)

J = torsional constant, in.⁴ (mm⁴)

K_z = *effective length factor* for torsional buckling

x_o, y_o = coordinates of shear center with respect to the centroid, in. (mm)

\bar{r}_o = polar radius of gyration about the shear center, in. (mm)

r_y = radius of gyration about y-axis, in. (mm)

User Note: For doubly symmetric I-shaped sections, C_w may be taken as $I_y h_o^2/4$, where h_o is the distance between flange centroids, in lieu of a more precise analysis. For tees and double angles, omit term with C_w when computing F_{ez} and take x_o as 0.

E5. SINGLE ANGLE COMPRESSION MEMBERS

The *nominal compressive strength*, P_n , of single angle members shall be determined in accordance with Section E3 or Section E7, as appropriate, for axially loaded members, as well as those subject to the slenderness modification of Section E5(a) or E5(b), provided the members meet the criteria imposed.

The effects of eccentricity on single angle members are permitted to be neglected when the members are evaluated as axially loaded compression members using one of the effective slenderness ratios specified below, provided that: (1) members are loaded at the ends in compression through the same one leg; (2) members are attached by welding or by minimum two-bolt *connections*; and (3) there are no intermediate transverse *loads*.

- (a) For equal-leg angles or unequal-leg angles connected through the longer leg that are individual members or are web members of planar trusses with adjacent web members attached to the same side of the *gusset plate* or chord:

- (i) When $0 \leq \frac{L}{r_x} \leq 80$:

$$\frac{KL}{r} = 72 + 0.75 \frac{L}{r_x} \quad (\text{E5-1})$$

- (ii) When $\frac{L}{r_x} > 80$:

$$\frac{KL}{r} = 32 + 1.25 \frac{L}{r_x} \leq 200 \quad (\text{E5-2})$$

For unequal-leg angles with leg length ratios less than 1.7 and connected through the shorter leg, KL/r from Equations E5-1 and E5-2 shall be increased by adding $4[(b_l/b_s)^2 - 1]$, but KL/r of the members shall not be less than $0.95L/r_z$.

- (b) For equal-leg angles or unequal-leg angles connected through the longer leg that are web members of box or space trusses with adjacent web members attached to the same side of the *gusset plate* or chord:

- (i) When $0 \leq \frac{L}{r_x} \leq 75$:

$$\frac{KL}{r} = 60 + 0.8 \frac{L}{r_x} \quad (\text{E5-3})$$

- (ii) When $\frac{L}{r_x} > 75$:

$$\frac{KL}{r} = 45 + \frac{L}{r_x} \leq 200 \quad (\text{E5-4})$$

For unequal-leg angles with leg length ratios less than 1.7 and connected through the shorter leg, KL/r from Equations E5-3 and E5-4 shall be increased by adding $6[(b_l/b_s)^2 - 1]$, but KL/r of the member shall not be less than $0.82L/r_z$,

where

L = length of member between work points at truss chord centerlines,
in. (mm)

b_l = longer leg of angle, in. (mm)

b_s = shorter leg of angle, in. (mm)

r_x = radius of gyration about *geometric axis* parallel to connected leg,
in. (mm)

r_z = radius of gyration for the minor principal axis, in. (mm)

- (c) Single angle members with different end conditions from those described in Section E5(a) or (b), with leg length ratios greater than 1.7, or with transverse loading shall be evaluated for combined axial *load* and flexure using the provisions of Chapter H. End connection to different legs on each end or to both

legs, the use of single bolts or the attachment of adjacent web members to opposite sides of the *gusset plate* or chord shall constitute different end conditions requiring the use of Chapter H provisions.

E6. BUILT-UP MEMBERS

1. Compressive Strength

(a) The *nominal compressive strength* of *built-up members* composed of two or more shapes that are interconnected by bolts or welds shall be determined in accordance with Sections E3, E4, or E7 subject to the following modification. In lieu of more accurate analysis, if the buckling mode involves relative deformations that produce shear *forces* in the connectors between individual shapes, KL/r is replaced by $(KL/r)_m$ determined as follows:

(i) For intermediate connectors that are snug-tight bolted:

$$\left(\frac{KL}{r}\right)_m = \sqrt{\left(\frac{KL}{r}\right)_o^2 + \left(\frac{a}{r_i}\right)^2} \quad (\text{E6-1})$$

(ii) For intermediate connectors that are welded or pretensioned bolted:

$$\left(\frac{KL}{r}\right)_m = \sqrt{\left(\frac{KL}{r}\right)_o^2 + 0.82 \frac{\alpha^2}{(1 + \alpha^2)} \left(\frac{a}{r_{ib}}\right)^2} \quad (\text{E6-2})$$

where

$\left(\frac{KL}{r}\right)_m$ = modified *column* slenderness of *built-up member*

$\left(\frac{KL}{r}\right)_o$ = column slenderness of built-up member acting as a unit in the buckling direction being considered

a = distance between connectors, in. (mm)

r_i = minimum radius of gyration of individual component, in. (mm)

r_{ib} = radius of gyration of individual component relative to its centroidal axis parallel to member axis of buckling, in. (mm)

α = separation ratio = $h/2r_{ib}$

h = distance between centroids of individual components perpendicular to the member axis of buckling, in. (mm)

(b) The nominal compressive strength of built-up members composed of two or more shapes or plates with at least one open side interconnected by perforated *cover plates* or *lacing* with *tie plates* shall be determined in accordance with Sections E3, E4, or E7 subject to the modification given in Section E6.1(a).

2. Dimensional Requirements

Individual components of compression members composed of two or more shapes shall be connected to one another at intervals, a , such that the effective slenderness

ratio Ka/r_i of each of the component shapes, between the *fasteners*, does not exceed three-fourths times the governing slenderness ratio of the *built-up member*. The least radius of gyration, r_i , shall be used in computing the slenderness ratio of each component part. The end *connection* shall be welded or pretensioned bolted with Class A or B *faying surfaces*.

User Note: It is acceptable to design a bolted end *connection* of a built-up compression member for the full compressive *load* with bolts in shear and bolt values based on bearing values; however, the bolts must be pretensioned. The requirement for Class A or B *faying surfaces* is not intended for the resistance of the axial force in the built-up member, but rather to prevent relative movement between the components at the end as the built-up member takes a curved shape.

At the ends of built-up compression members bearing on base plates or *milled surfaces*, all components in contact with one another shall be connected by a weld having a length not less than the maximum width of the member or by bolts spaced longitudinally not more than four diameters apart for a distance equal to $1\frac{1}{2}$ times the maximum width of the member.

Along the length of built-up compression members between the end connections required above, longitudinal spacing for intermittent welds or bolts shall be adequate to provide for the transfer of the required *forces*. For limitations on the longitudinal spacing of fasteners between elements in continuous contact consisting of a plate and a shape or two plates, see Section J3.5. Where a component of a built-up compression member consists of an outside plate, the maximum spacing shall not exceed the thickness of the thinner outside plate times $0.75\sqrt{E/F_y}$, nor 12 in. (305 mm), when intermittent welds are provided along the edges of the components or when fasteners are provided on all *gage lines* at each section. When fasteners are staggered, the maximum spacing on each *gage line* shall not exceed the thickness of the thinner outside plate times $1.12\sqrt{E/F_y}$, nor 18 in. (460 mm).

Open sides of compression members built up from plates or shapes shall be provided with continuous *cover plates* perforated with a succession of access holes. The unsupported width of such plates at access holes, as defined in Section B4, is assumed to contribute to the *available strength* provided the following requirements are met:

- (1) The width-thickness ratio shall conform to the limitations of Section B4.

User Note: It is conservative to use the limiting width/thickness ratio for Case 14 in Table B4.1 with the width, b , taken as the transverse distance between the nearest lines of fasteners. The net area of the plate is taken at the widest hole. In lieu of this approach, the limiting width thickness ratio may be determined through analysis.

- (2) The ratio of length (in direction of *stress*) to width of hole shall not exceed two.
- (3) The clear distance between holes in the direction of stress shall be not less than the transverse distance between nearest lines of connecting fasteners or welds.
- (4) The periphery of the holes at all points shall have a minimum radius of $1\frac{1}{2}$ in. (38 mm).

As an alternative to perforated cover plates, *lacing* with *tie plates* is permitted at each end and at intermediate points if the lacing is interrupted. Tie plates shall be as near the ends as practicable. In members providing *available strength*, the end tie plates shall have a length of not less than the distance between the lines of fasteners or welds connecting them to the components of the member. Intermediate tie plates shall have a length not less than one-half of this distance. The thickness of tie plates shall be not less than one-fiftieth of the distance between lines of welds or fasteners connecting them to the segments of the members. In welded construction, the welding on each line connecting a tie plate shall total not less than one-third the length of the plate. In bolted construction, the spacing in the direction of stress in tie plates shall be not more than six diameters and the tie plates shall be connected to each segment by at least three fasteners.

Lacing, including flat bars, angles, channels, or other shapes employed as lacing, shall be so spaced that the L/r ratio of the flange included between their connections shall not exceed three-fourths times the governing slenderness ratio for the member as a whole. Lacing shall be proportioned to provide a shearing strength normal to the axis of the member equal to 2 percent of the *available compressive strength* of the member. The L/r ratio for lacing bars arranged in single systems shall not exceed 140. For double lacing this ratio shall not exceed 200. Double lacing bars shall be joined at the intersections. For lacing bars in compression, l is permitted to be taken as the unsupported length of the *lacing* bar between welds or fasteners connecting it to the components of the *built-up member* for single lacing, and 70 percent of that distance for double lacing.

User Note: The inclination of lacing bars to the axis of the member shall preferably be not less than 60° for single lacing and 45° for double lacing. When the distance between the lines of welds or fasteners in the flanges is more than 15 in. (380 mm), the lacing shall preferably be double or be made of angles.

For additional spacing requirements, see Section J3.5.

E7. MEMBERS WITH SLENDER ELEMENTS

This section applies to compression members with slender sections, as defined in Section B4 for uniformly compressed elements.

The *nominal compressive strength*, P_n , shall be determined based on the *limit states of flexural, torsional and flexural-torsional buckling*.

$$P_n = F_{cr} A_g \quad (E7-1)$$

$$(a) \text{ When } \frac{KL}{r} \leq 4.71 \sqrt{\frac{E}{QF_y}} \quad (\text{or } F_e \geq 0.44QF_y)$$

$$F_{cr} = Q \left[0.658 \frac{QF_y}{F_e} \right] F_y \quad (\text{E7-2})$$

$$(b) \text{ When } \frac{KL}{r} > 4.71 \sqrt{\frac{E}{QF_y}} \quad (\text{or } F_e < 0.44QF_y)$$

$$F_{cr} = 0.877F_e \quad (\text{E7-3})$$

where

F_e = elastic critical buckling stress, calculated using Equations E3-4 and E4-4 for doubly symmetric members, Equations E3-4 and E4-5 for singly symmetric members, and Equation E4-6 for unsymmetric members, except for single angles where F_e is calculated using Equation E3-4.

$Q = 1.0$ for members with *compact* and *noncompact sections*, as defined in Section B4, for uniformly compressed elements

= $Q_s Q_a$ for members with *slender-element sections*, as defined in Section B4, for uniformly compressed elements.

User Note: For cross sections composed of only unstiffened slender elements, $Q = Q_s$ ($Q_a = 1.0$). For cross sections composed of only stiffened slender elements, $Q = Q_a$ ($Q_s = 1.0$). For cross sections composed of both stiffened and unstiffened slender elements, $Q = Q_s Q_a$.

1. Slender Unstiffened Elements, Q_s

The reduction factor Q_s for slender *unstiffened elements* is defined as follows:

(a) For flanges, angles, and plates projecting from rolled *columns* or other compression members:

$$(i) \text{ When } \frac{b}{t} \leq 0.56 \sqrt{\frac{E}{F_y}}$$

$$Q_s = 1.0 \quad (\text{E7-4})$$

$$(ii) \text{ When } 0.56 \sqrt{E/F_y} < b/t < 1.03 \sqrt{E/F_y}$$

$$Q_s = 1.415 - 0.74 \left(\frac{b}{t} \right) \sqrt{\frac{F_y}{E}} \quad (\text{E7-5})$$

$$(iii) \text{ When } b/t \geq 1.03 \sqrt{E/F_y}$$

$$Q_s = \frac{0.69E}{F_y \left(\frac{b}{t} \right)^2} \quad (\text{E7-6})$$

(b) For flanges, angles, and plates projecting from built-up columns or other compression members:

$$(i) \text{ When } \frac{b}{t} \leq 0.64 \sqrt{\frac{Ek_c}{F_y}} \quad Q_s = 1.0 \quad (E7-7)$$

$$(ii) \text{ When } 0.64 \sqrt{\frac{Ek_c}{F_y}} < b/t \leq 1.17 \sqrt{\frac{Ek_c}{F_y}} \quad Q_s = 1.415 - 0.65 \left(\frac{b}{t}\right) \sqrt{\frac{F_y}{Ek_c}} \quad (E7-8)$$

$$(iii) \text{ When } b/t > 1.17 \sqrt{\frac{Ek_c}{F_y}} \quad Q_s = \frac{0.90Ek_c}{F_y \left(\frac{b}{t}\right)^2} \quad (E7-9)$$

where

$$k_c = \frac{4}{\sqrt{h/t_w}}, \text{ and shall not be taken less than } 0.35 \text{ nor greater than } 0.76 \text{ for calculation purposes}$$

(c) For single angles

$$(i) \text{ When } \frac{b}{t} \leq 0.45 \sqrt{\frac{E}{F_y}} \quad Q_s = 1.0 \quad (E7-10)$$

$$(ii) \text{ When } 0.45 \sqrt{E/F_y} < b/t \leq 0.91 \sqrt{E/F_y} \quad Q_s = 1.34 - 0.76 \left(\frac{b}{t}\right) \sqrt{\frac{F_y}{E}} \quad (E7-11)$$

$$(iii) \text{ When } b/t > 0.91 \sqrt{E/F_y} \quad Q_s = \frac{0.53E}{F_y \left(\frac{b}{t}\right)^2} \quad (E7-12)$$

where

$$b = \text{full width of longest angle leg, in. (mm)}$$

(d) For stems of tees

$$(i) \text{ When } \frac{d}{t} \leq 0.75 \sqrt{\frac{E}{F_y}} \quad Q_s = 1.0 \quad (E7-13)$$

$$(ii) \text{ When } 0.75\sqrt{\frac{E}{F_y}} < d/t \leq 1.03\sqrt{\frac{E}{F_y}}$$

$$Q_s = 1.908 - 1.22 \left(\frac{d}{t} \right) \sqrt{\frac{F_y}{E}} \quad (E7-14)$$

$$(iii) \text{ When } d/t > 1.03\sqrt{\frac{E}{F_y}}$$

$$Q_s = \frac{0.69E}{F_y \left(\frac{d}{t} \right)^2} \quad (E7-15)$$

where

b = width of unstiffened compression element, as defined in Section B4,
in. (mm)

d = the full nominal depth of tee, in. (mm)

t = thickness of element, in. (mm)

2. Slender Stiffened Elements, Q_a

The reduction factor, Q_a , for slender *stiffened elements* is defined as follows:

$$Q_a = \frac{A_{eff}}{A} \quad (E7-16)$$

where

A = total cross-sectional area of member, in.² (mm²)

A_{eff} = summation of the effective areas of the cross section based on the reduced *effective width*, b_e , in.² (mm²)

The reduced effective width, b_e , is determined as follows:

- (a) For uniformly compressed slender elements, with $\frac{b}{t} \geq 1.49\sqrt{\frac{E}{f}}$, except flanges of square and rectangular sections of uniform thickness:

$$b_e = 1.92t\sqrt{\frac{E}{f}} \left[1 - \frac{0.34}{(b/t)}\sqrt{\frac{E}{f}} \right] \leq b \quad (E7-17)$$

where

f is taken as F_{cr} with F_{cr} calculated based on $Q = 1.0$.

- (b) For flanges of square and rectangular *slender-element sections* of uniform thickness with $\frac{b}{t} \geq 1.40\sqrt{\frac{E}{f}}$:

$$b_e = 1.92t\sqrt{\frac{E}{f}} \left[1 - \frac{0.38}{(b/t)}\sqrt{\frac{E}{f}} \right] \leq b \quad (E7-18)$$

where

$$f = P_n / A_{eff}$$

User Note: In lieu of calculating $f = P_n / A_{eff}$, which requires iteration, f may be taken equal to F_y . This will result in a slightly conservative estimate of column capacity.

(c) For axially-loaded circular sections:

$$\text{When } 0.11 \frac{E}{F_y} < \frac{D}{t} < 0.45 \frac{E}{F_y}$$

$$Q = Q_a = \frac{0.038E}{F_y(D/t)} + \frac{2}{3} \quad (\text{E7-19})$$

where

D = outside diameter, in. (mm)

t = wall thickness, in. (mm)

CHAPTER F

DESIGN OF MEMBERS FOR FLEXURE

This chapter applies to members subject to simple bending about one principal axis. For simple bending, the member is loaded in a plane parallel to a principal axis that passes through the shear center or is restrained against twisting at *load* points and supports.

The chapter is organized as follows:







- F1. General Provisions
- F2. Doubly Symmetric Compact I-Shaped Members and Channels Bent about Their Major Axis
- F3. Doubly Symmetric I-Shaped Members with Compact Webs and Noncompact or Slender Flanges Bent about Their Major Axis
- F4. Other I-Shaped Members with Compact or Noncompact Webs Bent about Their Major Axis
- F5. Doubly Symmetric and Singly Symmetric I-Shaped Members with Slender Webs Bent about Their Major Axis
- F6. I-Shaped Members and Channels Bent about Their Minor Axis
- F7. Square and Rectangular HSS and Box-Shaped Members
- F8. Round HSS
- F9. Tees and Double Angles Loaded in the Plane of Symmetry
- F10. Single Angles
- F11. Rectangular Bars and Rounds
- F12. Unsymmetrical Shapes
- F13. Proportions of Beams and Girders

User Note: For members not included in this chapter the following sections apply:

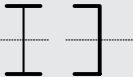
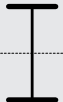
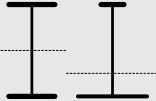
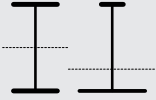
- H1–H3. Members subject to biaxial flexure or to combined flexure and axial force.
- H4. Members subject to flexure and torsion.
- Appendix 3. Members subject to fatigue.
- Chapter G. Design provisions for shear.

For guidance in determining the appropriate sections of this chapter to apply, Table User Note F1.1 may be used.

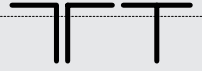
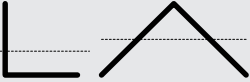
TABLE User Note F1.1
Selection Table for the Application
of Chapter F Sections

Section in Chapter F	Cross Section	Flange Slenderness	Web Slenderness	Limit States
F2		C	C	Y, LTB
F3		NC, S	C	LTB, FLB
F4		C, NC, S	C, NC	Y, LTB, FLB, TFY
F5		C, NC, S	S	Y, LTB, FLB, TFY
F6		C, NC, S	N/A	Y, FLB
F7		C, NC, S	C, NC	Y, FLB, WLB
F8		N/A	N/A	Y, LB
F9		C, NC, S	N/A	Y, LTB, FLB
F10		N/A	N/A	Y, LTB, LLB
F11		N/A	N/A	Y, LTB
F12	Unsymmetrical shapes	N/A	N/A	All limit states

Y = yielding, LTB = lateral-torsional buckling, FLB = flange local buckling, WLB = web local buckling, TFY = tension flange yielding, LLB = leg local buckling, LB = local buckling, C = compact, NC = noncompact, S = slender

F1. GENERAL PROVISIONS

The *design flexural strength*, $\phi_b M_n$, and the *allowable flexural strength*, M_n/Ω_b , shall be determined as follows:

- (1) For all provisions in this chapter

$$\phi_b = 0.90 \text{ (LRFD)} \quad \Omega_b = 1.67 \text{ (ASD)}$$

and the *nominal flexural strength*, M_n , shall be determined according to Sections F2 through F12.

- (2) The provisions in this chapter are based on the assumption that points of support for *beams* and *girders* are restrained against rotation about their longitudinal axis.

The following terms are common to the equations in this chapter except where noted:

C_b = *lateral-torsional buckling* modification factor for nonuniform moment diagrams when both ends of the unsupported segment are braced

$$C_b = \frac{12.5M_{\max}}{2.5M_{\max} + 3M_A + 4M_B + 3M_C} R_m \leq 3.0 \quad (\text{F1-1})$$

where

M_{\max} = absolute value of maximum moment in the unbraced segment, kip-in. (N-mm)

M_A = absolute value of moment at quarter point of the unbraced segment, kip-in. (N-mm)

M_B = absolute value of moment at centerline of the unbraced segment, kip-in. (N-mm)

M_C = absolute value of moment at three-quarter point of the unbraced segment, kip-in. (N-mm)

R_m = cross-section monosymmetry parameter

= 1.0, doubly symmetric members

= 1.0, singly symmetric members subjected to *single curvature* bending

= $0.5 + 2 \left(\frac{I_{yc}}{I_y} \right)^2$, singly symmetric members subjected to *reverse curvature* bending

I_y = moment of inertia about the principal y-axis, in.⁴ (mm⁴)

I_{yc} = moment of inertia about y-axis referred to the compression flange, or if reverse curvature bending, referred to the smaller flange, in.⁴ (mm⁴)

In singly symmetric members subjected to *reverse curvature* bending, the *lateral-torsional buckling* strength shall be checked for both flanges. The available flexural strength shall be greater than or equal to the maximum required moment causing compression within the flange under consideration.

C_b is permitted to be conservatively taken as 1.0 for all cases. For cantilevers or overhangs where the free end is unbraced, $C_b = 1.0$.

User Note: For doubly symmetric members with no transverse loading between brace points, Equation F1-1 reduces to 2.27 for the case of equal end moments of opposite sign and to 1.67 when one end moment equals zero.

F2. DOUBLY SYMMETRIC COMPACT I-SHAPED MEMBERS AND CHANNELS BENT ABOUT THEIR MAJOR AXIS

This section applies to doubly symmetric I-shaped members and channels bent about their major axis, having compact webs and compact flanges as defined in Section B4.

User Note: All current ASTM A6 W, S, M, C and MC shapes except W21×48, W14×99, W14×90, W12×65, W10×12, W8×31, W8×10, W6×15, W6×9, W6×8.5, and M4×6 have compact flanges for $F_y \leq 50$ ksi (345 MPa); all current ASTM A6 W, S, M, HP, C and MC shapes have compact webs at $F_y \leq 65$ ksi (450 MPa).

The *nominal flexural strength*, M_n , shall be the lower value obtained according to the *limit states of yielding (plastic moment)* and *lateral-torsional buckling*.

1. Yielding

$$M_n = M_p = F_y Z_x \quad (\text{F2-1})$$

where

F_y = specified minimum yield stress of the type of steel being used, ksi (MPa)
 Z_x = plastic section modulus about the x-axis, in.³ (mm³)

2. Lateral-Torsional Buckling

(a) When $L_b \leq L_p$, the limit state of lateral-torsional buckling does not apply.

(b) When $L_p < L_b \leq L_r$

$$M_n = C_b \left[M_p - (M_p - 0.7F_y S_x) \left(\frac{L_b - L_p}{L_r - L_p} \right) \right] \leq M_p \quad (\text{F2-2})$$

(c) When $L_b > L_r$

$$M_n = F_{cr} S_x \leq M_p \quad (\text{F2-3})$$

where

L_b = length between points that are either braced against lateral displacement of compression flange or braced against twist of the cross section, in. (mm)

$$F_{cr} = \frac{C_b \pi^2 E}{\left(\frac{L_b}{r_{ts}} \right)^2} \sqrt{1 + 0.078 \frac{Jc}{S_x h_o} \left(\frac{L_b}{r_{ts}} \right)^2} \quad (\text{F2-4})$$

and where

E = modulus of elasticity of steel = 29,000 ksi (200 000 MPa)

J = torsional constant, in.⁴ (mm⁴)

S_x = elastic section modulus taken about the x-axis, in.³ (mm³)

User Note: The square root term in Equation F2-4 may be conservatively taken equal to 1.0.

The limiting lengths L_p and L_r are determined as follows:

$$L_p = 1.76r_y \sqrt{\frac{E}{F_y}} \quad (\text{F2-5})$$

$$L_r = 1.95r_{ts} \frac{E}{0.7F_y} \sqrt{\frac{Jc}{S_x h_o}} \sqrt{1 + \sqrt{1 + 6.76 \left(\frac{0.7F_y S_x h_o}{E Jc} \right)^2}} \quad (\text{F2-6})$$

where

$$r_{ts}^2 = \frac{\sqrt{I_y C_w}}{S_x} \quad (\text{F2-7})$$

and

$$\text{For a doubly symmetric I-shape: } c = 1 \quad (\text{F2-8a})$$

$$\text{For a channel: } c = \frac{h_o}{2} \sqrt{\frac{I_y}{C_w}} \quad (\text{F2-8b})$$

where

$$h_o = \text{distance between the flange centroids, in. (mm)}$$

User Note: If the square root term in Equation F2-4 is conservatively taken equal to 1, Equation F2-6 becomes

$$L_r = \pi r_{ts} \sqrt{\frac{E}{0.7F_y}}$$

Note that this approximation can be extremely conservative.

For doubly symmetric I-shapes with rectangular flanges, $C_w = \frac{I_y h_o^2}{4}$ and thus Equation F2-7 becomes

$$r_{ts}^2 = \frac{I_y h_o}{2S_x}$$

r_{ts} may be approximated accurately and conservatively as the radius of gyration of the compression flange plus one-sixth of the web:

$$r_{ts} = \frac{b_f}{\sqrt{12 \left(1 + \frac{1}{6} \frac{h t_w}{b_f t_f} \right)}}$$

F3. DOUBLY SYMMETRIC I-SHAPED MEMBERS WITH COMPACT WEBS AND NONCOMPACT OR SLENDER FLANGES BENT ABOUT THEIR MAJOR AXIS

This section applies to doubly symmetric I-shaped members bent about their major axis having compact webs and noncompact or slender flanges as defined in Section B4.

User Note: The following shapes have noncompact flanges for $F_y = 50$ ksi (345 MPa): W21×48, W14×99, W14×90, W12×65, W10×12, W8×31, W8×10, W6×15, W6×9, W6×8.5, and M4×6. All other ASTM A6 W, S, M, and HP shapes have compact flanges for $F_y \leq 50$ ksi (345 MPa).

The nominal flexural strength, M_n , shall be the lower value obtained according to the *limit states of lateral-torsional buckling* and *compression flange local buckling*.

1. Lateral-Torsional Buckling

For *lateral-torsional buckling*, the provisions of Section F2.2 shall apply.

2. Compression Flange Local Buckling

(a) For sections with noncompact flanges

$$M_n = \left[M_p - (M_p - 0.7F_y S_x) \left(\frac{\lambda - \lambda_{pf}}{\lambda_{rf} - \lambda_{pf}} \right) \right] \quad (\text{F3-1})$$

(b) For sections with slender flanges

$$M_n = \frac{0.9E k_c S_x}{\lambda^2} \quad (\text{F3-2})$$

where

$$\lambda = \frac{b_f}{2t_f}$$

$\lambda_{pf} = \lambda_p$ is the limiting slenderness for a compact flange, Table B4.1

$\lambda_{rf} = \lambda_r$ is the limiting slenderness for a noncompact flange, Table B4.1

$k_c = \frac{4}{\sqrt{h/t_w}}$ and shall not be taken less than 0.35 nor greater than 0.76 for calculation purposes

F4. OTHER I-SHAPED MEMBERS WITH COMPACT OR NONCOMPACT WEBS BENT ABOUT THEIR MAJOR AXIS

This section applies to: (a) doubly symmetric I-shaped members bent about their major axis with noncompact webs; and (b) singly symmetric I-shaped members with webs attached to the mid-width of the flanges, bent about their major axis, with compact or noncompact webs, as defined in Section B4.

User Note: I-shaped members for which this section is applicable may be designed conservatively using Section F5.

The nominal flexural strength, M_n , shall be the lowest value obtained according to the *limit states* of compression flange yielding, lateral-torsional buckling, compression flange local buckling and tension flange yielding.

1. Compression Flange Yielding

$$M_n = R_{pc}M_{yc} = R_{pc}F_yS_{xc} \quad (\text{F4-1})$$

2. Lateral-Torsional Buckling

(a) When $L_b \leq L_p$, the *limit state* of lateral-torsional buckling does not apply.

(b) When $L_p < L_b \leq L_r$

$$M_n = C_b \left[R_{pc}M_{yc} - (R_{pc}M_{yc} - F_L S_{xc}) \left(\frac{L_b - L_p}{L_r - L_p} \right) \right] \leq R_{pc}M_{yc} \quad (\text{F4-2})$$

(c) When $L_b > L_r$

$$M_n = F_{cr}S_{xc} \leq R_{pc}M_{yc} \quad (\text{F4-3})$$

where

$$M_{yc} = F_y S_{xc} \quad (\text{F4-4})$$

$$F_{cr} = \frac{C_b \pi^2 E}{\left(\frac{L_b}{r_t} \right)^2} \sqrt{1 + 0.078 \frac{J}{S_{xc} h_o} \left(\frac{L_b}{r_t} \right)^2} \quad (\text{F4-5})$$

For $\frac{I_{yc}}{I_y} \leq 0.23$, J shall be taken as zero.

The stress, F_L , is determined as follows:

(i) For $\frac{S_{xt}}{S_{xc}} \geq 0.7$

$$F_L = 0.7F_y \quad (\text{F4-6a})$$

(ii) For $\frac{S_{xt}}{S_{xc}} < 0.7$

$$F_L = F_y \frac{S_{xt}}{S_{xc}} \geq 0.5F_y \quad (\text{F4-6b})$$

The limiting laterally unbraced length for the limit state of yielding, L_p , is

$$L_p = 1.1r_t \sqrt{\frac{E}{F_y}} \quad (\text{F4-7})$$

The limiting unbraced length for the limit state of inelastic lateral-torsional buckling, L_r , is

$$L_r = 1.95r_t \frac{E}{F_L} \sqrt{\frac{J}{S_{xc} h_o}} \sqrt{1 + \sqrt{1 + 6.76 \left(\frac{F_L S_{xc} h_o}{E J} \right)^2}} \quad (\text{F4-8})$$

The web *plastification* factor, R_{pc} , is determined as follows:

(i) For $\frac{h_c}{t_w} \leq \lambda_{pw}$

$$R_{pc} = \frac{M_p}{M_{yc}} \quad (\text{F4-9a})$$

(ii) For $\frac{h_c}{t_w} > \lambda_{pw}$

$$R_{pc} = \left[\frac{M_p}{M_{yc}} - \left(\frac{M_p}{M_{yc}} - 1 \right) \left(\frac{\lambda - \lambda_{pw}}{\lambda_{rw} - \lambda_{pw}} \right) \right] \leq \frac{M_p}{M_{yc}} \quad (\text{F4-9b})$$

where

$$M_p = Z_x F_y \leq 1.6 S_{xc} F_y$$

S_{xc} , S_{xt} = elastic section modulus referred to tension and compression flanges, respectively, in.³ (mm³)

$$\lambda = \frac{h_c}{t_w}$$

λ_{pw} = λ_p , the limiting slenderness for a compact web, Table B4.1

λ_{rw} = λ_r , the limiting slenderness for a noncompact web, Table B4.1

The effective radius of gyration for lateral-torsional buckling, r_t , is determined as follows:

(i) For I-shapes with a rectangular compression flange:

$$r_t = \frac{b_{fc}}{\sqrt{12 \left(\frac{h_o}{d} + \frac{1}{6} a_w \frac{h^2}{h_o d} \right)}} \quad (\text{F4-10})$$

where

$$a_w = \frac{h_c t_w}{b_{fc} t_{fc}} \quad (\text{F4-11})$$

b_{fc} = compression flange width, in. (mm)

t_{fc} = compression flange thickness, in. (mm)

(ii) For I-shapes with channel caps or *cover plates* attached to the compression flange:

r_t = radius of gyration of the flange components in flexural compression plus one-third of the web area in compression due to application of major axis bending moment alone, in. (mm)

a_w = the ratio of two times the web area in compression due to application of major axis bending moment alone to the area of the compression flange components

User Note: For I-shapes with a rectangular compression flange, r_t may be approximated accurately and conservatively as the radius of gyration of the compression flange plus one-third of the compression portion of the web; in other words,

$$r_t = \frac{b_{fc}}{\sqrt{12 \left(1 + \frac{1}{6}a_w\right)}}$$

3. Compression Flange Local Buckling

(a) For sections with compact flanges, the *limit state of local buckling* does not apply.

(b) For sections with noncompact flanges

$$M_n = \left[R_{pc} M_{yc} - (R_{pc} M_{yc} - F_L S_{xc}) \left(\frac{\lambda - \lambda_{pf}}{\lambda_{rf} - \lambda_{pf}} \right) \right] \quad (\text{F4-12})$$

(c) For sections with slender flanges

$$M_n = \frac{0.9 E k_c S_{xc}}{\lambda^2} \quad (\text{F4-13})$$

where

F_L is defined in Equations F4-6a and F4-6b

R_{pc} is the web *plastification* factor, determined by Equations F4-9

$k_c = \frac{4}{\sqrt{h/t_w}}$ and shall not be taken less than 0.35 nor greater than 0.76 for calculation purposes

$$\lambda = \frac{b_{fc}}{2t_{fc}}$$

$\lambda_{pf} = \lambda_p$, the limiting slenderness for a compact flange, Table B4.1

$\lambda_{rf} = \lambda_r$, the limiting slenderness for a noncompact flange, Table B4.1

4. Tension Flange Yielding

(a) When $S_{xt} \geq S_{xc}$, the *limit state of tension flange yielding* does not apply.

(b) When $S_{xt} < S_{xc}$

$$M_n = R_{pt} M_{yt} \quad (\text{F4-14})$$

where

$$M_{yt} = F_y S_{xt}$$

The web *plastification* factor corresponding to the tension flange yielding limit state, R_{pt} , is determined as follows:

(i) For $\frac{h_c}{t_w} \leq \lambda_{pw}$

$$R_{pt} = \frac{M_p}{M_{yt}} \quad (\text{F4-15a})$$

(ii) For $\frac{h_c}{t_w} > \lambda_{pw}$

$$R_{pt} = \left[\frac{M_p}{M_{yt}} - \left(\frac{M_p}{M_{yt}} - 1 \right) \left(\frac{\lambda - \lambda_{pw}}{\lambda_{rw} - \lambda_{pw}} \right) \right] \leq \frac{M_p}{M_{yt}} \quad (\text{F4-15b})$$

where

$$\lambda = \frac{h_c}{t_w}$$

$\lambda_{pw} = \lambda_p$, the limiting slenderness for a compact web, defined in Table B4.1

$\lambda_{rw} = \lambda_r$, the limiting slenderness for a noncompact web, defined in Table B4.1

F5. DOUBLY SYMMETRIC AND SINGLY SYMMETRIC I-SHAPED MEMBERS WITH SLENDER WEBS BENT ABOUT THEIR MAJOR AXIS

This section applies to doubly symmetric and singly symmetric I-shaped members with slender webs attached to the mid-width of the flanges, bent about their major axis, as defined in Section B4.

The nominal flexural strength, M_n , shall be the lowest value obtained according to the *limit states* of compression flange yielding, lateral-torsional buckling, compression flange local buckling and tension flange yielding.

1. Compression Flange Yielding

$$M_n = R_{pg} F_y S_{xc} \quad (\text{F5-1})$$

2. Lateral-Torsional Buckling

$$M_n = R_{pg} F_{cr} S_{xc} \quad (\text{F5-2})$$

(a) When $L_b \leq L_p$, the *limit state* of lateral-torsional buckling does not apply.

(b) When $L_p < L_b \leq L_r$

$$F_{cr} = C_b \left[F_y - (0.3F_y) \left(\frac{L_b - L_p}{L_r - L_p} \right) \right] \leq F_y \quad (\text{F5-3})$$

(c) When $L_b > L_r$

$$F_{cr} = \frac{C_b \pi^2 E}{\left(\frac{L_b}{r_t} \right)^2} \leq F_y \quad (\text{F5-4})$$

where

L_p is defined by Equation F4-7

$$L_r = \pi r_t \sqrt{\frac{E}{0.7F_y}} \quad (\text{F5-5})$$

R_{pg} is the bending strength reduction factor:

$$R_{pg} = 1 - \frac{a_w}{1200 + 300a_w} \left(\frac{h_c}{t_w} - 5.7 \sqrt{\frac{E}{F_y}} \right) \leq 1.0 \quad (\text{F5-6})$$

a_w is defined by Equation F4-11 but shall not exceed 10
and

r_t is the effective radius of gyration for lateral buckling as defined in Section F4.

3. Compression Flange Local Buckling

$$M_n = R_{pg} F_{cr} S_{xc} \quad (\text{F5-7})$$

(a) For sections with compact flanges, the *limit state* of compression flange *local buckling* does not apply.

(b) For sections with noncompact flanges

$$F_{cr} = \left[F_y - (0.3F_y) \left(\frac{\lambda - \lambda_{pf}}{\lambda_{rf} - \lambda_{pf}} \right) \right] \quad (\text{F5-8})$$

(c) For sections with slender flange sections

$$F_{cr} = \frac{0.9Ek_c}{\left(\frac{b_f}{2t_f} \right)^2} \quad (\text{F5-9})$$

where

$k_c = \frac{4}{\sqrt{h/t_w}}$ and shall not be taken less than 0.35 nor greater than 0.76 for calculation purposes

$$\lambda = \frac{b_{fc}}{2t_{fc}}$$

$\lambda_{pf} = \lambda_p$, the limiting slenderness for a compact flange, Table B4.1

$\lambda_{rf} = \lambda_r$, the limiting slenderness for a noncompact flange, Table B4.1

4. Tension Flange Yielding

(a) When $S_{xt} \geq S_{xc}$, the *limit state* of tension flange *yielding* does not apply.

(b) When $S_{xt} < S_{xc}$

$$M_n = F_y S_{xt} \quad (\text{F5-10})$$

F6. I-SHAPED MEMBERS AND CHANNELS BENT ABOUT THEIR MINOR AXIS

This section applies to I-shaped members and channels bent about their minor axis.

The nominal flexural strength, M_n , shall be the lower value obtained according to the *limit states* of *yielding* (*plastic moment*) and *flange local buckling*.

1. Yielding

$$M_n = M_p = F_y Z_y \leq 1.6F_y S_y \quad (\text{F6-1})$$

2. Flange Local Buckling

(a) For sections with compact flanges the limit state of yielding shall apply.

User Note: All current ASTM A6 W, S, M, C and MC shapes except W21×48, W14×99, W14×90, W12×65, W10×12, W8×31, W8×10, W6×15, W6×9, W6×8.5, and M4×6 have compact flanges at $F_y \leq 50$ ksi (345 MPa).

(b) For sections with noncompact flanges

$$M_n = \left[M_p - (M_p - 0.7F_y S_y) \left(\frac{\lambda - \lambda_{pf}}{\lambda_{rf} - \lambda_{pf}} \right) \right] \quad (\text{F6-2})$$

(c) For sections with slender flanges

$$M_n = F_{cr} S_y \quad (\text{F6-3})$$

where

$$F_{cr} = \frac{0.69E}{\left(\frac{b_f}{2t_f} \right)^2} \quad (\text{F6-4})$$

$$\lambda = \frac{b}{t}$$

$\lambda_{pf} = \lambda_p$, the limiting slenderness for a compact flange, Table B4.1

$\lambda_{rf} = \lambda_r$, the limiting slenderness for a noncompact flange, Table B4.1

S_y for a channel shall be taken as the minimum section modulus

F7. SQUARE AND RECTANGULAR HSS AND BOX-SHAPED MEMBERS

This section applies to square and rectangular *HSS*, and doubly symmetric box-shaped members bent about either axis, having compact or noncompact webs and compact, noncompact or slender flanges as defined in Section B4.

The nominal flexural strength, M_n , shall be the lowest value obtained according to the *limit states* of yielding (*plastic moment*), flange *local buckling* and web *local buckling* under pure flexure.

1. Yielding

$$M_n = M_p = F_y Z \quad (\text{F7-1})$$

where

Z = plastic section modulus about the axis of bending, in.³ (mm³)

2. Flange Local Buckling

(a) For *compact sections*, the *limit state* of flange *local buckling* does not apply.

(b) For sections with noncompact flanges

$$M_n = M_p - (M_p - F_y S) \left(3.57 \frac{b}{t} \sqrt{\frac{F_y}{E}} - 4.0 \right) \leq M_p \quad (\text{F7-2})$$

(c) For sections with slender flanges

$$M_n = F_y S_{eff} \quad (\text{F7-3})$$

where

S_{eff} is the *effective section modulus* determined with the *effective width* of the compression flange taken as:

$$b_e = 1.92t \sqrt{\frac{E}{F_y}} \left[1 - \frac{0.38}{b/t} \sqrt{\frac{E}{F_y}} \right] \leq b \quad (\text{F7-4})$$

3. Web Local Buckling

- (a) For *compact sections*, the *limit state* of web *local buckling* does not apply.
 (b) For sections with noncompact webs

$$M_n = M_p - (M_p - F_y S_x) \left(0.305 \frac{h}{t_w} \sqrt{\frac{F_y}{E}} - 0.738 \right) \leq M_p \quad (\text{F7-5})$$

F8. ROUND HSS

This section applies to round *HSS* having D/t ratios of less than $\frac{0.45E}{F_y}$.

The nominal flexural strength, M_n , shall be the lower value obtained according to the *limit states* of *yielding* (*plastic moment*) and *local buckling*.

1. Yielding

$$M_n = M_p = F_y Z \quad (\text{F8-1})$$

2. Local Buckling

- (a) For *compact sections*, the *limit state* of flange *local buckling* does not apply.
 (b) For noncompact sections

$$M_n = \left(\frac{0.021E}{\frac{D}{t}} + F_y \right) S \quad (\text{F8-2})$$

(c) For sections with slender walls

$$M_n = F_{cr} S \quad (\text{F8-3})$$

where

$$F_{cr} = \frac{0.33E}{\frac{D}{t}} \quad (\text{F8-4})$$

S = elastic section modulus, in.³ (mm³)

F9. TEES AND DOUBLE ANGLES LOADED IN THE PLANE OF SYMMETRY

This section applies to tees and double angles loaded in the plane of symmetry.

The nominal flexural strength, M_n , shall be the lowest value obtained according to the *limit states* of *yielding (plastic moment)*, *lateral-torsional buckling* and *flange local buckling*.

1. Yielding

$$M_n = M_p \quad (\text{F9-1})$$

where

$$M_p = F_y Z_x \leq 1.6 M_y \quad \text{for stems in tension} \quad (\text{F9-2})$$

$$\leq M_y \quad \text{for stems in compression} \quad (\text{F9-3})$$

2. Lateral-Torsional Buckling

$$M_n = M_{cr} = \frac{\pi \sqrt{E I_y G J}}{L_b} \left[B + \sqrt{1 + B^2} \right] \quad (\text{F9-4})$$

where

$$B = \pm 2.3 \left(\frac{d}{L_b} \right) \sqrt{\frac{I_y}{J}} \quad (\text{F9-5})$$

The plus sign for B applies when the stem is in tension and the minus sign applies when the stem is in compression. If the tip of the stem is in compression anywhere along the *unbraced length*, the negative value of B shall be used.

3. Flange Local Buckling of Tees

$$M_n = F_{cr} S_{xc} \quad (\text{F9-6})$$

S_{xc} is the elastic section modulus referred to the compression flange.

F_{cr} is determined as follows:

(a) For *compact sections*, the *limit state* of *flange local buckling* does not apply.

(b) For noncompact sections

$$F_{cr} = F_y \left(1.19 - 0.50 \left(\frac{b_f}{2t_f} \right) \sqrt{\frac{F_y}{E}} \right) \quad (\text{F9-7})$$

(c) For slender sections

$$F_{cr} = \frac{0.69E}{\left(\frac{b_f}{2t_f} \right)^2} \quad (\text{F9-8})$$

F10. SINGLE ANGLES

This section applies to single angles with and without continuous lateral restraint along their length.

Single angles with continuous lateral-torsional restraint along the length shall be permitted to be designed on the basis of *geometric axis* (x , y) bending. Single angles without continuous lateral-torsional restraint along the length shall be designed using the provisions for *principal axis* bending except where the provision for bending about a geometric axis is permitted.

User Note: For geometric axis design, use section properties computed about the x - and y -axis of the angle, parallel and perpendicular to the legs. For principal axis design use section properties computed about the major and minor principal axes of the angle.

The *nominal flexural strength*, M_n , shall be the lowest value obtained according to the *limit states of yielding (plastic moment), lateral-torsional buckling* and *leg local buckling*.

1. Yielding

$$M_n = 1.5M_y \quad (\text{F10-1})$$

where

M_y = yield moment about the axis of bending, kip-in. (N-mm)

2. Lateral-Torsional Buckling

For single angles without continuous lateral-torsional restraint along the length

(a) When $M_e \leq M_y$

$$M_n = \left(0.92 - \frac{0.17M_e}{M_y} \right) M_e \quad (\text{F10-2})$$

(b) When $M_e > M_y$

$$M_n = \left(1.92 - 1.17\sqrt{\frac{M_y}{M_e}} \right) M_y \leq 1.5M_y \quad (\text{F10-3})$$

where

M_e , the elastic *lateral-torsional buckling* moment, is determined as follows:

(i) For bending about one of the *geometric axes* of an equal-leg angle with no lateral-torsional restraint

(a) With maximum compression at the toe

$$M_e = \frac{0.66Eb^4tC_b}{L^2} \left(\sqrt{1 + 0.78 \left(\frac{Lt}{b^2} \right)^2} - 1 \right) \quad (\text{F10-4a})$$

(b) With maximum tension at the toe

$$M_e = \frac{0.66Eb^4tC_b}{L^2} \left(\sqrt{1 + 0.78 \left(\frac{Lt}{b^2} \right)^2} + 1 \right) \quad (\text{F10-4b})$$

M_y shall be taken as 0.80 times the *yield moment* calculated using the geometric section modulus.

User Note: M_n may be taken as M_y for single angles with their vertical leg toe in compression, and having a span-to-depth ratio less than or equal to

$$\frac{1.64E}{F_y} \sqrt{\left(\frac{t}{b}\right)^2 - 1.4 \frac{F_y}{E}}$$

- (ii) For bending about one of the geometric axes of an equal-leg angle with lateral-torsional restraint at the point of maximum moment only

M_e shall be taken as 1.25 times M_e computed using Equation F10-4a or F10-4b.

M_y shall be taken as the yield moment calculated using the geometric section modulus.

- (iii) For bending about the major principal axis of equal-leg angles:

$$M_e = \frac{0.46Eb^2t^2C_b}{L} \quad (\text{F10-5})$$

- (iv) For bending about the major principal axis of unequal-leg angles:

$$M_e = \frac{4.9EI_z C_b}{L^2} \left(\sqrt{\beta_w^2 + 0.052 \left(\frac{Lt}{r_z}\right)^2} + \beta_w \right) \quad (\text{F10-6})$$

where

C_b is computed using Equation F1-1 with a maximum value of 1.5.

L = laterally *unbraced length* of a member, in. (mm)

I_z = minor principal axis moment of inertia, in.⁴ (mm⁴)

r_z = radius of gyration for the minor principal axis, in. (mm)

t = angle leg thickness, in. (mm)

β_w = a section property for unequal leg angles, positive for short legs in compression and negative for long legs in compression. If the long leg is in compression anywhere along the unbraced length of the member, the negative value of β_w shall be used.

User Note: The equation for β_w and values for common angle sizes are listed in the Commentary.

3. Leg Local Buckling

The *limit state* of leg *local buckling* applies when the toe of the leg is in compression.

- (a) For *compact sections*, the limit state of leg local buckling does not apply.
 (b) For sections with noncompact legs

$$M_n = F_y S_c \left(2.43 - 1.72 \left(\frac{b}{t}\right) \sqrt{\frac{F_y}{E}} \right) \quad (\text{F10-7})$$

(c) For sections with slender legs

$$M_n = F_{cr} S_c \quad (\text{F10-8})$$

where

$$F_{cr} = \frac{0.71E}{\left(\frac{b}{t}\right)^2} \quad (\text{F10-9})$$

b = outside width of leg in compression, in. (mm)

S_c = elastic section modulus to the toe in compression relative to the axis of bending, in.³ (mm³). For bending about one of the *geometric axes* of an equal-leg angle with no lateral-torsional restraint, S_c shall be 0.80 of the geometric axis section modulus.

F11. RECTANGULAR BARS AND ROUNDS

This section applies to rectangular bars bent about either *geometric axis* and rounds.

The *nominal flexural strength*, M_n , shall be the lower value obtained according to the *limit states* of *yielding (plastic moment)* and *lateral-torsional buckling*, as required.

1. Yielding

For rectangular bars with $\frac{L_b d}{t^2} \leq \frac{0.08E}{F_y}$ bent about their major axis, rectangular bars bent about their minor axis, and rounds:

$$M_n = M_p = F_y Z \leq 1.6M_y \quad (\text{F11-1})$$

2. Lateral-Torsional Buckling

(a) For rectangular bars with $\frac{0.08E}{F_y} < \frac{L_b d}{t^2} \leq \frac{1.9E}{F_y}$ bent about their major axis:

$$M_n = C_b \left[1.52 - 0.274 \left(\frac{L_b d}{t^2} \right) \frac{F_y}{E} \right] M_y \leq M_p \quad (\text{F11-2})$$

(b) For rectangular bars with $\frac{L_b d}{t^2} > \frac{1.9E}{F_y}$ bent about their major axis:

$$M_n = F_{cr} S_x \leq M_p \quad (\text{F11-3})$$

where

$$F_{cr} = \frac{1.9EC_b}{\frac{L_b d}{t^2}} \quad (\text{F11-4})$$

t = width of rectangular bar parallel to axis of bending, in. (mm)

d = depth of rectangular bar, in. (mm)

L_b = length between points that are either braced against lateral displacement of the compression region or braced against twist of the cross section, in. (mm)

- (c) For rounds and rectangular bars bent about their minor axis, the *limit state of lateral-torsional buckling* need not be considered.

F12. UNSYMMETRICAL SHAPES

This section applies to all unsymmetrical shapes, except single angles.

The *nominal flexural strength*, M_n , shall be the lowest value obtained according to the *limit states of yielding (yield moment), lateral-torsional buckling and local buckling* where

$$M_n = F_n S \quad (\text{F12-1})$$

where

S = lowest elastic section modulus relative to the axis of bending, in.³ (mm³)

1. Yielding

$$F_n = F_y \quad (\text{F12-2})$$

2. Lateral-Torsional Buckling

$$F_n = F_{cr} \leq F_y \quad (\text{F12-3})$$

where

F_{cr} = buckling *stress* for the section as determined by analysis, ksi (MPa)

User Note: In the case of Z-shaped members, it is recommended that F_{cr} be taken as $0.5F_{cr}$ of a channel with the same flange and web properties.

3. Local Buckling

$$F_n = F_{cr} \leq F_y \quad (\text{F12-4})$$

where

F_{cr} = buckling *stress* for the section as determined by analysis, ksi (MPa)

F13. PROPORTIONS OF BEAMS AND GIRDERS

1. Hole Reductions

This section applies to rolled or built-up shapes, and cover-plated *beams* with holes, proportioned on the basis of flexural strength of the gross section.

In addition to the *limit states* specified in other sections of this Chapter, the *nominal flexural strength*, M_n , shall be limited according to the limit state of *tensile rupture* of the tension flange.

- (a) For $F_u A_{fn} \geq Y_t F_y A_{fg}$, the limit state of tensile rupture does not apply.

- (b) For $F_u A_{fn} < Y_t F_y A_{fg}$, the nominal flexural strength, M_n , at the location of the holes in the tension flange shall not be taken greater than:

$$M_n = \frac{F_u A_{fn}}{A_{fg}} S_x \quad (\text{F13-1})$$

where

A_{fg} = gross tension flange area, calculated in accordance with the provisions of Section D3.1, in.² (mm²)

A_{fn} = net tension flange area, calculated in accordance with the provisions of Section D3.2, in.² (mm²)

Y_t = 1.0 for $F_y/F_u \leq 0.8$
= 1.1 otherwise

2. Proportioning Limits for I-Shaped Members

Singly symmetric I-shaped members shall satisfy the following limit:

$$0.1 \leq \frac{I_{yc}}{I_y} \leq 0.9 \quad (\text{F13-2})$$

I-shaped members with slender webs shall also satisfy the following limits:

- (a) For $\frac{a}{h} \leq 1.5$

$$\left(\frac{h}{t_w}\right)_{\max} = 11.7 \sqrt{\frac{E}{F_y}} \quad (\text{F13-3})$$

- (b) For $\frac{a}{h} > 1.5$

$$\left(\frac{h}{t_w}\right)_{\max} = \frac{0.42E}{F_y} \quad (\text{F13-4})$$

where

a = clear distance between *transverse stiffeners*, in. (mm)

In unstiffened girders h/t_w shall not exceed 260. The ratio of the web area to the compression flange area shall not exceed 10.

3. Cover Plates

Flanges of welded *beams* or girders may be varied in thickness or width by splicing a series of plates or by the use of *cover plates*.

The total cross-sectional area of cover plates of bolted girders shall not exceed 70 percent of the total flange area.

High-strength bolts or welds connecting flange to web, or cover plate to flange, shall be proportioned to resist the total *horizontal shear* resulting from the bending forces on the girder. The longitudinal distribution of these bolts or intermittent welds shall be in proportion to the intensity of the shear.

However, the longitudinal spacing shall not exceed the maximum permitted for compression or tension members in Section E6 or D4, respectively. Bolts or welds connecting flange to web shall also be proportioned to transmit to the web any *loads* applied directly to the flange, unless provision is made to transmit such loads by direct bearing.

Partial-length cover plates shall be extended beyond the theoretical cutoff point and the extended portion shall be attached to the beam or girder by high-strength bolts in a slip-critical *connection* or *fillet welds*. The attachment shall be adequate, at the applicable strength given in Sections J2.2, J3.8, or B3.9 to develop the cover plate's portion of the flexural strength in the beam or girder at the theoretical cutoff point.

For welded cover plates, the welds connecting the cover plate termination to the beam or girder shall have continuous welds along both edges of the cover plate in the length a' , defined below, and shall be adequate to develop the cover plate's portion of the strength of the beam or girder at the distance a' from the end of the cover plate.

- (a) When there is a continuous weld equal to or larger than three-fourths of the plate thickness across the end of the plate

$$a' = w \quad (\text{F13-5})$$

where

w = width of cover plate, in. (mm)

- (b) When there is a continuous weld smaller than three-fourths of the plate thickness across the end of the plate

$$a' = 1.5w \quad (\text{F13-6})$$

- (c) When there is no weld across the end of the plate

$$a' = 2w \quad (\text{F13-7})$$

4. Built-Up Beams

Where two or more *beams* or channels are used side-by-side to form a flexural member, they shall be connected together in compliance with Section E6.2. When concentrated *loads* are carried from one beam to another, or distributed between the beams, *diaphragms* having sufficient *stiffness* to distribute the load shall be welded or bolted between the beams.

CHAPTER G

DESIGN OF MEMBERS FOR SHEAR

This chapter addresses webs of singly or doubly symmetric members subject to shear in the plane of the web, single angles and *HSS* sections, and shear in the weak direction of singly or doubly symmetric shapes.

The chapter is organized as follows:

- G1. General Provisions
- G2. Members with Unstiffened or Stiffened Webs
- G3. Tension Field Action
- G4. Single Angles
- G5. Rectangular HSS and Box Members
- G6. Round HSS
- G7. Weak Axis Shear in Singly and Doubly Symmetric Shapes
- G8. Beams and Girders with Web Openings

User Note: For applications not included in this chapter, the following sections apply:

- H3.3 Unsymmetric sections.
- J4.2 Shear strength of connecting elements.
- J10.6 Web panel zone shear.

G1. GENERAL PROVISIONS

Two methods of calculating shear strength are presented below. The method presented in Section G2 does not utilize the post *buckling strength* of the member (*tension field action*). The method presented in Section G3 utilizes tension field action.

The *design shear strength*, $\phi_v V_n$, and the *allowable shear strength*, V_n/Ω_v , shall be determined as follows.

For all provisions in this chapter except Section G2.1a:

$$\phi_v = 0.90 \text{ (LRFD)} \quad \Omega_v = 1.67 \text{ (ASD)}$$

G2. MEMBERS WITH UNSTIFFENED OR STIFFENED WEBS

1. Nominal Shear Strength

This section applies to webs of singly or doubly symmetric members and channels subject to shear in the plane of the web.

The *nominal shear strength*, V_n , of unstiffened or stiffened webs, according to the *limit states* of *shear yielding* and *shear buckling*, is

$$V_n = 0.6F_y A_w C_v \quad (\text{G2-1})$$

(a) For webs of rolled I-shaped members with $h/t_w \leq 2.24\sqrt{E/F_y}$:

$$\phi_v = 1.00 \text{ (LRFD)} \quad \Omega_v = 1.50 \text{ (ASD)}$$

and

$$C_v = 1.0 \quad (\text{G2-2})$$

User Note: All current ASTM A6 W, S and HP shapes except W44×230, W40×149, W36×135, W33×118, W30×90, W24×55, W16×26 and W12×14 meet the criteria stated in Section G2.1(a) for $F_y \leq 50$ ksi (345 MPa).

(b) For webs of all other doubly symmetric shapes and singly symmetric shapes and channels, except round *HSS*, the web shear coefficient, C_v , is determined as follows:

(i) For $h/t_w \leq 1.10\sqrt{k_v E/F_y}$

$$C_v = 1.0 \quad (\text{G2-3})$$

(ii) For $1.10\sqrt{k_v E/F_y} < h/t_w \leq 1.37\sqrt{k_v E/F_y}$

$$C_v = \frac{1.10\sqrt{k_v E/F_y}}{h/t_w} \quad (\text{G2-4})$$

(iii) For $h/t_w > 1.37\sqrt{k_v E/F_y}$

$$C_v = \frac{1.51Ek_v}{(h/t_w)^2 F_y} \quad (\text{G2-5})$$

where

A_w = the overall depth times the web thickness, dt_w , in.² (mm²)

The web plate buckling coefficient, k_v , is determined as follows:

(i) For unstiffened webs with $h/t_w < 260$, $k_v = 5$ except for the stem of tee shapes where $k_v = 1.2$.

(ii) For stiffened webs,

$$\begin{aligned} k_v &= 5 + \frac{5}{(a/h)^2} \\ &= 5 \text{ when } a/h > 3.0 \text{ or } a/h > \left[\frac{260}{(h/t_w)} \right]^2 \end{aligned}$$

where

a = clear distance between transverse *stiffeners*, in. (mm)

h = for rolled shapes, the clear distance between flanges less the fillet or corner radii, in. (mm)

- = for built-up welded sections, the clear distance between flanges, in. (mm)
- = for built-up bolted sections, the distance between *fastener* lines, in. (mm)
- = for tees, the overall depth, in. (mm)

User Note: For all ASTM A6 W, S, M and HP shapes except M12.5×12.4, M12.5×11.6, M12×11.8, M12×10.8, M12×10, M10×8, and M10×7.5, when $F_y \leq 50$ ksi (345 MPa), $C_v = 1.0$.

2. Transverse Stiffeners

Transverse *stiffeners* are not required where $h/t_w \leq 2.46\sqrt{E/F_y}$, or where the required shear strength is less than or equal to the available shear strength provided in accordance with Section G2.1 for $k_v = 5$.

Transverse stiffeners used to develop the available web shear strength, as provided in Section G2.1, shall have a moment of inertia about an axis in the web center for *stiffener* pairs or about the face in contact with the web plate for single stiffeners, which shall not be less than $at_w^3 j$, where

$$j = \frac{2.5}{(a/h)^2} - 2 \geq 0.5 \quad (\text{G2-6})$$

Transverse stiffeners are permitted to be stopped short of the tension flange, provided bearing is not needed to transmit a concentrated load or reaction. The weld by which transverse stiffeners are attached to the web shall be terminated not less than four times nor more than six times the web thickness from the near toe to the web-to-flange weld. When single stiffeners are used, they shall be attached to the compression flange, if it consists of a rectangular plate, to resist any uplift tendency due to torsion in the flange. When *lateral bracing* is attached to a stiffener, or a pair of stiffeners, these, in turn, shall be connected to the compression flange to transmit 1 percent of the total flange *force*, unless the flange is composed only of angles.

Bolts connecting stiffeners to the girder web shall be spaced not more than 12 in. (305 mm) on center. If intermittent *fillet welds* are used, the clear distance between welds shall not be more than 16 times the web thickness nor more than 10 in. (250 mm).

G3. TENSION FIELD ACTION

1. Limits on the Use of Tension Field Action

Consideration of *tension field action* is permitted for flanged members when the web plate is supported on all four sides by flanges or *stiffeners*. Consideration of tension field action is not permitted for:

- (a) *end panels* in all members with transverse stiffeners;
- (b) members when a/h exceeds 3.0 or $[260/(h/t_w)]^2$;
- (c) $2A_w/(A_{fc} + A_{ft}) > 2.5$; or
- (d) h/b_{fc} or $h/b_{ft} > 6.0$

where

A_{fc} = area of compression flange, in.² (mm²)

A_{ft} = area of tension flange, in.² (mm²)

b_{fc} = width of compression flange, in. (mm)

b_{ft} = width of tension flange, in. (mm)

In these cases, the nominal shear strength, V_n , shall be determined according to the provisions of Section G2.

2. Nominal Shear Strength with Tension Field Action

When *tension field action* is permitted according to Section G3.1, the nominal shear strength, V_n , with tension field action, according to the *limit state* of tension field yielding, shall be

(a) For $h/t_w \leq 1.10\sqrt{k_v E/F_y}$

$$V_n = 0.6F_y A_w \quad (\text{G3-1})$$

(b) For $h/t_w > 1.10\sqrt{k_v E/F_y}$

$$V_n = 0.6F_y A_w \left(C_v + \frac{1 - C_v}{1.15\sqrt{1 + (a/h)^2}} \right) \quad (\text{G3-2})$$

where

k_v and C_v are as defined in Section G2.1.

3. Transverse Stiffeners

Transverse *stiffeners* subject to *tension field action* shall meet the requirements of Section G2.2 and the following limitations:

(1) $(b/t)_{st} \leq 0.56\sqrt{\frac{E}{F_{yst}}}$

(2) $A_{st} > \frac{F_y}{F_{yst}} \left[0.15D_s h t_w (1 - C_v) \frac{V_r}{V_c} - 18t_w^2 \right] \geq 0 \quad (\text{G3-3})$

where

$(b/t)_{st}$ = the width-thickness ratio of the stiffener

F_{yst} = *specified minimum yield stress* of the stiffener material, ksi (MPa)

C_v = coefficient defined in Section G2.1

D_s = 1.0 for stiffeners in pairs

= 1.8 for single angle stiffeners

= 2.4 for single plate stiffeners

V_r = *required shear strength* at the location of the stiffener, kips (N)

V_c = *available shear strength*; $\phi_v V_n$ (LRFD) or V_n/Ω_v (ASD) with V_n as defined in Section G3.2, kips (N)

G4. SINGLE ANGLES

The nominal shear strength, V_n , of a single angle leg shall be determined using Equation G2-1 with $C_v = 1.0$, $A_w = bt$ where $b =$ width of the leg resisting the shear force, in. (mm) and $k_v = 1.2$.

G5. RECTANGULAR HSS AND BOX MEMBERS

The nominal shear strength, V_n , of rectangular HSS and box members shall be determined using the provisions of Section G2.1 with $A_w = 2ht$ where h for the width resisting the shear force shall be taken as the clear distance between the flanges less the inside corner radius on each side and $t_w = t$ and $k_v = 5$. If the corner radius is not known, h shall be taken as the corresponding outside dimension minus three times the thickness.

G6. ROUND HSS

The nominal shear strength, V_n , of round HSS, according to the limit states of shear yielding and shear buckling, is

$$V_n = F_{cr} A_g / 2 \quad (\text{G6-1})$$

where

F_{cr} shall be the larger of

$$F_{cr} = \frac{1.60E}{\sqrt{\frac{L_v}{D}} \left(\frac{D}{t}\right)^{4/3}} \quad (\text{G6-2a})$$

and

$$F_{cr} = \frac{0.78E}{\left(\frac{D}{t}\right)^{3/2}} \quad (\text{G6-2b})$$

but shall not exceed $0.6F_y$

$A_g =$ gross area of section based on design wall thickness, in.² (mm²)

$D =$ outside diameter, in. (mm)

$L_v =$ the distance from maximum to zero shear force, in. (mm)

$t =$ design wall thickness, equal to 0.93 times the nominal wall thickness for ERW HSS and equal to the nominal thickness for SAW HSS, in. (mm)

User Note: The shear buckling equations, Equations G6-2a and G6-2b, will control for D/t over 100, high strength steels, and long lengths. If the shear strength for standard sections is desired, shear yielding will usually control.

G7. WEAK AXIS SHEAR IN SINGLY AND DOUBLY SYMMETRIC SHAPES

For singly and doubly symmetric shapes loaded in the weak axis without torsion, the nominal shear strength, V_n , for each shear resisting element shall be determined using Equation G2-1 and Section G2.1(b) with $A_w = b_f t_f$ and $k_v = 1.2$.

User Note: For all ASTM A6 W, S, M and HP shapes, when $F_y \leq 50$ ksi (345 MPa), $C_v = 1.0$.

G8. BEAMS AND GIRDERS WITH WEB OPENINGS

The effect of all web openings on the nominal shear strength of steel and *composite beams* shall be determined. Adequate reinforcement shall be provided when the *required strength* exceeds the *available strength* of the member at the opening.

CHAPTER H

DESIGN OF MEMBERS FOR COMBINED FORCES AND TORSION

This chapter addresses members subject to axial *force* and flexure about one or both axes, with or without torsion, and to members subject to torsion only.

The chapter is organized as follows:

- H1. Doubly and Singly Symmetric Members Subject to Flexure and Axial Force
- H2. Unsymmetric and Other Members Subject to Flexure and Axial Force
- H3. Members under Torsion and Combined Torsion, Flexure, Shear and/or Axial Force

User Note: For *composite* members, see Chapter I.

H1. DOUBLY AND SINGLY SYMMETRIC MEMBERS SUBJECT TO FLEXURE AND AXIAL FORCE

1. Doubly and Singly Symmetric Members in Flexure and Compression

The interaction of flexure and compression in doubly symmetric members and singly symmetric members for which $0.1 \leq (I_{yc}/I_y) \leq 0.9$, that are constrained to bend about a *geometric axis* (x and/or y) shall be limited by Equations H1-1a and H1-1b, where I_{yc} is the moment of inertia about the y-axis referred to the compression flange, in.⁴ (mm⁴).

User Note: Section H2 is permitted to be used in lieu of the provisions of this section.

(a) For $\frac{P_r}{P_c} \geq 0.2$

$$\frac{P_r}{P_c} + \frac{8}{9} \left(\frac{M_{rx}}{M_{cx}} + \frac{M_{ry}}{M_{cy}} \right) \leq 1.0 \quad (\text{H1-1a})$$

(b) For $\frac{P_r}{P_c} < 0.2$

$$\frac{P_r}{2P_c} + \left(\frac{M_{rx}}{M_{cx}} + \frac{M_{ry}}{M_{cy}} \right) \leq 1.0 \quad (\text{H1-1b})$$

where

P_r = required axial compressive strength, kips (N)

P_c = available axial compressive strength, kips (N)

M_r = required flexural strength, kip-in. (N-mm)

M_c = available flexural strength, kip-in. (N-mm)

x = subscript relating symbol to *strong axis* bending

y = subscript relating symbol to *weak axis* bending

For design according to Section B3.3 (LRFD)

P_r = required axial compressive strength using LRFD load combinations, kips (N)

$P_c = \phi_c P_n$ = design axial compressive strength, determined in accordance with Chapter E, kips (N)

M_r = required flexural strength using LRFD load combinations, kip-in. (N-mm)

$M_c = \phi_b M_n$ = design flexural strength determined in accordance with Chapter F, kip-in. (N-mm)

ϕ_c = resistance factor for compression = 0.90

ϕ_b = resistance factor for flexure = 0.90

For design according to Section B3.4 (ASD)

P_r = required axial compressive strength using ASD load combinations, kips (N)

$P_c = P_n / \Omega_c$ = allowable axial compressive strength, determined in accordance with Chapter E, kips (N)

M_r = required flexural strength using ASD load combinations, kip-in. (N-mm)

$M_c = M_n / \Omega_b$ = allowable flexural strength determined in accordance with Chapter F, kip-in. (N-mm)

Ω_c = safety factor for compression = 1.67

Ω_b = safety factor for flexure = 1.67

2. Doubly and Singly Symmetric Members in Flexure and Tension

The interaction of flexure and tension in doubly symmetric members and singly symmetric members constrained to bend about a *geometric axis* (x and/or y) shall be limited by Equations H1-1a and H1-1b,

where

For design according to Section B3.3 (LRFD)

P_r = required tensile strength using LRFD load combinations, kips (N)

$P_c = \phi_t P_n$ = design tensile strength, determined in accordance with Section D2, kips (N)

M_r = required flexural strength using LRFD load combinations, kip-in. (N-mm)

$M_c = \phi_b M_n$ = design flexural strength determined in accordance with Chapter F, kip-in. (N-mm)

ϕ_t = resistance factor for tension (see Section D2)

ϕ_b = resistance factor for flexure = 0.90

For doubly symmetric members, C_b in Chapter F may be increased by $\sqrt{1 + \frac{P_u}{P_{ey}}}$ for axial tension that acts concurrently with flexure,

where

$$P_{ey} = \frac{\pi^2 EI_y}{L_b^2}$$

For design according to Section B3.4 (ASD)

P_r = required tensile strength using *ASD load combinations*, kips (N)

$P_c = P_n / \Omega_t =$ allowable tensile strength, determined in accordance with Section D2, kips (N)

M_r = required flexural strength using ASD load combinations, kip-in. (N-mm)

$M_c = M_n / \Omega_b =$ allowable flexural strength determined in accordance with Chapter F, kip-in. (N-mm)

$\Omega_t =$ safety factor for tension (see Section D2)

$\Omega_b =$ safety factor for flexure = 1.67

For doubly symmetric members, C_b in Chapter F may be increased by

$$\sqrt{1 + \frac{1.5 P_a}{P_{ey}}}$$

for axial tension that acts concurrently with flexure

where

$$P_{ey} = \frac{\pi^2 EI_y}{L_b^2}$$

A more detailed analysis of the interaction of flexure and tension is permitted in lieu of Equations H1-1a and H1-1b.

3. Doubly Symmetric Members in Single Axis Flexure and Compression

For doubly symmetric members in flexure and compression with moments primarily in one plane, it is permissible to consider the two independent *limit states*, *in-plane instability* and *out-of-plane buckling* or *flexural-torsional buckling*, separately in lieu of the combined approach provided in Section H1.1.

(a) For the limit state of in-plane instability, Equations H1-1 shall be used with P_c , M_r , and M_c determined in the plane of bending.

(b) For the limit state of out-of-plane buckling

$$\frac{P_r}{P_{co}} + \left(\frac{M_r}{M_{cx}} \right)^2 \leq 1.0 \quad (\text{H1-2})$$

where

$P_{co} =$ available compressive strength out of the plane of bending, kips (N)

$M_{cx} =$ available flexural-torsional strength for strong axis flexure determined from Chapter F, kip-in. (N-mm)

If bending occurs only about the *weak axis*, the moment ratio in Equation H1-2 shall be neglected.

For members with significant biaxial moments ($M_r/M_c \geq 0.05$ in both directions), the provisions of Section H1.1 shall be followed.

H2. UNSYMMETRIC AND OTHER MEMBERS SUBJECT TO FLEXURE AND AXIAL FORCE

This section addresses the interaction of flexure and axial *stress* for shapes not covered in Section H1. It is permitted to use the provisions of this Section for any shape in lieu of the provisions of Section H1.

$$\left| \frac{f_a}{F_a} + \frac{f_{bw}}{F_{bw}} + \frac{f_{bz}}{F_{bz}} \right| \leq 1.0 \quad (\text{H2-1})$$

where

- f_a = required axial stress at the point of consideration, ksi (MPa)
- F_a = available axial stress at the point of consideration, ksi (MPa)
- f_{bw}, f_{bz} = required flexural stress at the point of consideration, ksi (MPa)
- F_{bw}, F_{bz} = available flexural stress at the point of consideration, ksi (MPa)
- w = subscript relating symbol to major principal axis bending
- z = subscript relating symbol to minor principal axis bending

For design according to Section B3.3 (LRFD)

- f_a = required axial stress using *LRFD load combinations*, ksi (MPa)
- F_a = $\phi_c F_{cr}$ = design axial stress, determined in accordance with Chapter E for compression or Section D2 for tension, ksi (MPa)
- f_{bw}, f_{bz} = required flexural stress at the specific location in the cross section using LRFD load combinations, ksi (MPa)
- $F_{bw}, F_{bz} = \frac{\phi_b M_n}{S}$ = design flexural stress determined in accordance with Chapter F, ksi (MPa). Use the section modulus for the specific location in the cross section and consider the sign of the stress.
- ϕ_c = resistance factor for compression = 0.90
- ϕ_t = resistance factor for tension (Section D2)
- ϕ_b = resistance factor for flexure = 0.90

For design according to Section B3.4 (ASD)

- f_a = required axial stress using *ASD load combinations*, ksi (MPa)
- $F_a = \frac{F_{cr}}{\Omega_c}$ = allowable axial stress determined in accordance with Chapter E for compression, or Section D2 for tension, ksi (MPa)
- f_{bw}, f_{bz} = required flexural stress at the specific location in the cross section using *ASD load combinations*, ksi (MPa)

$F_{bw}, F_{bz} = \frac{M_n}{\Omega_b S} = \text{allowable flexural stress}$ determined in accordance with Chapter F, ksi (MPa). Use the section modulus for the specific location in the cross section and consider the sign of the stress.

$\Omega_c = \text{safety factor for compression} = 1.67$

$\Omega_t = \text{safety factor for tension (Section D2)}$

$\Omega_b = \text{safety factor for flexure} = 1.67$

Equation H2-1 shall be evaluated using the principal bending axes by considering the sense of the flexural stresses at the critical points of the cross section. The flexural terms are either added to or subtracted from the axial term as appropriate. When the axial force is compression, second order effects shall be included according to the provisions of Chapter C.

A more detailed analysis of the interaction of flexure and tension is permitted in lieu of Equation H2-1.

H3. MEMBERS UNDER TORSION AND COMBINED TORSION, FLEXURE, SHEAR AND/OR AXIAL FORCE

1. Torsional Strength of Round and Rectangular HSS

The *design torsional strength*, $\phi_T T_n$, and the *allowable torsional strength*, T_n/Ω_T , for round and rectangular HSS shall be determined as follows:

$$\phi_T = 0.90 \text{ (LRFD)} \quad \Omega_T = 1.67 \text{ (ASD)}$$

The nominal torsional strength, T_n , according to the *limit states of torsional yielding* and *torsional buckling* is:

$$T_n = F_{cr} C \quad (\text{H3-1})$$

where

C is the HSS torsional constant

F_{cr} shall be determined as follows:

(a) For round HSS, F_{cr} shall be the larger of

$$F_{cr} = \frac{1.23E}{\sqrt{\frac{L}{D} \left(\frac{D}{t}\right)^{\frac{5}{4}}}} \quad (\text{H3-2a})$$

and

$$F_{cr} = \frac{0.60E}{\left(\frac{D}{t}\right)^{\frac{3}{2}}} \quad (\text{H3-2b})$$

but shall not exceed $0.6F_y$,

where

L = length of the member, in. (mm)

D = outside diameter, in. (mm)

(b) For rectangular *HSS*

(i) For $h/t \leq 2.45\sqrt{E/F_y}$

$$F_{cr} = 0.6F_y \quad (\text{H3-3})$$

(ii) For $2.45\sqrt{E/F_y} < h/t \leq 3.07\sqrt{E/F_y}$

$$F_{cr} = 0.6F_y(2.45\sqrt{E/F_y})/(h/t) \quad (\text{H3-4})$$

(iii) For $3.07\sqrt{E/F_y} < h/t \leq 260$

$$F_{cr} = 0.458\pi^2 E/(h/t)^2 \quad (\text{H3-5})$$

User Note: The torsional shear constant, C , may be conservatively taken as:

$$\text{For a round } HSS: C = \frac{\pi(D-t)^2 t}{2}$$

$$\text{For rectangular } HSS: C = 2(B-t)(H-t)t - 4.5(4-\pi)t^3$$

2. HSS Subject to Combined Torsion, Shear, Flexure and Axial Force

When the *required torsional strength*, T_r , is less than or equal to 20 percent of the *available torsional strength*, T_c , the interaction of torsion, shear, flexure and/or axial force for *HSS* shall be determined by Section H1 and the torsional effects shall be neglected. When T_r exceeds 20 percent of T_c , the interaction of torsion, shear, flexure and/or axial force shall be limited by

$$\left(\frac{P_r}{P_c} + \frac{M_r}{M_c}\right) + \left(\frac{V_r}{V_c} + \frac{T_r}{T_c}\right)^2 \leq 1.0 \quad (\text{H3-6})$$

where

For design according to Section B3.3 (LRFD)

P_r = required axial strength using LRFD load combinations, kips (N)

P_c = ϕP_n , design tensile or compressive strength in accordance with Chapter D or E, kips (N)

M_r = required flexural strength using LRFD load combinations, kip-in. (N-mm)

M_c = $\phi_b M_n$, design flexural strength in accordance with Chapter F, kip-in. (N-mm)

V_r = required shear strength using LRFD load combinations, kips (N)

V_c = $\phi_v V_n$, design shear strength in accordance with Chapter G, kips (N)

T_r = required torsional strength using LRFD load combinations, kip-in. (N-mm)

T_c = $\phi_T T_n$, design torsional strength in accordance with Section H3.1, kip-in. (N-mm)

For design according to Section B3.4 (ASD)

P_r = required axial strength using *ASD load combinations*, kips (N)

$P_c = P_n/\Omega$, *allowable tensile or compressive strength* in accordance with Chapter D or E, kips (N)

M_r = required flexural strength using *ASD load combinations* determined in accordance with Section B5, kip-in. (N-mm)

$M_c = M_n/\Omega_b$, *allowable flexural strength* in accordance with Chapter F, kip-in. (N-mm)

V_r = required shear strength using *ASD load combinations*, kips (N)

$V_c = V_n/\Omega_v$, *allowable shear strength* in accordance with Chapter G, kips (N)

T_r = required torsional strength using *ASD load combinations*, kip-in. (N-mm)

$T_c = T_n/\Omega_T$, *allowable torsional strength* in accordance with Section H3.1, kip-in. (N-mm)

3. Strength of Non-HSS Members under Torsion and Combined Stress

The *design torsional strength*, $\phi_T F_n$, and the *allowable torsional strength*, F_n/Ω_T , for non-HSS members shall be the lowest value obtained according to the *limit states of yielding* under normal stress, *shear yielding* under shear stress, or *buckling*, determined as follows:

$$\phi_T = 0.90 \text{ (LRFD)} \quad \Omega_T = 1.67 \text{ (ASD)}$$

(a) For the limit state of yielding under normal stress

$$F_n = F_y \quad \text{(H3-7)}$$

(b) For the limit state of shear yielding under shear stress

$$F_n = 0.6F_y \quad \text{(H3-8)}$$

(c) For the limit state of buckling

$$F_n = F_{cr} \quad \text{(H3-9)}$$

where

F_{cr} = buckling stress for the section as determined by analysis, ksi (MPa)

Some constrained local yielding is permitted adjacent to areas that remain elastic.

CHAPTER I

DESIGN OF COMPOSITE MEMBERS

This chapter addresses *composite columns* composed of rolled or built-up structural steel shapes or *HSS*, and structural concrete acting together, and steel *beams* supporting a reinforced concrete slab so interconnected that the beams and the slab act together to resist bending. Simple and continuous *composite beams* with *shear connectors* and *concrete-encased beams*, constructed with or without temporary shores, are included.

The chapter is organized as follows:

- I1. General Provisions
- I2. Axial Members
- I3. Flexural Members
- I4. Combined Axial Force and Flexure
- I5. Special Cases

I1. GENERAL PROVISIONS

In determining *load effects* in members and *connections* of a structure that includes *composite* members, consideration shall be given to the effective sections at the time each increment of *load* is applied. The design, detailing and material properties related to the concrete and reinforcing steel portions of composite construction shall comply with the reinforced concrete and reinforcing bar design specifications stipulated by the *applicable building code*. In the absence of a building code, the provisions in ACI 318 shall apply.

1. Nominal Strength of Composite Sections

Two methods are provided for determining the *nominal strength* of *composite* sections: the *plastic stress distribution method* and the *strain-compatibility method*.

The *tensile strength* of the concrete shall be neglected in the determination of the nominal strength of composite members.

1a. Plastic Stress Distribution Method

For the plastic stress distribution method, the nominal strength shall be computed assuming that steel components have reached a *stress* of F_y in either tension or compression and concrete components in compression have reached a *stress* of $0.85 f'_c$. For round *HSS* filled with concrete, a *stress* of $0.95 f'_c$ is permitted to be used for concrete components in uniform compression to account for the effects of concrete confinement.

1b. Strain-Compatibility Method

For the strain compatibility method, a linear distribution of strains across the section shall be assumed, with the maximum concrete compressive strain equal to 0.003 in./in. (mm/mm). The stress-strain relationships for steel and concrete shall be obtained from tests or from published results for similar materials.

User Note: The strain compatibility method should be used to determine nominal strength for irregular sections and for cases where the steel does not exhibit elasto-plastic behavior. General guidelines for the strain-compatibility method for encased columns are given in AISC Design Guide 6 and ACI 318 Sections 10.2 and 10.3.

2. Material Limitations

Concrete and steel reinforcing bars in *composite* systems shall be subject to the following limitations.

- (1) For the determination of the *available strength*, concrete shall have a compressive strength f'_c of not less than 3 ksi (21 MPa) nor more than 10 ksi (70 MPa) for normal weight concrete and not less than 3 ksi (21 MPa) nor more than 6 ksi (42 MPa) for lightweight concrete.

User Note: Higher strength concrete materials may be used for *stiffness* calculations but may not be relied upon for strength calculations unless justified by testing or analysis.

- (2) The *specified minimum yield stress* of structural steel and reinforcing bars used in calculating the strength of a *composite column* shall not exceed 75 ksi (525 MPa).

Higher material strengths are permitted when their use is justified by testing or analysis.

User Note: Additional reinforced concrete material limitations are specified in ACI 318.

3. Shear Connectors

Shear connectors shall be headed steel studs not less than four stud diameters in length after installation, or hot-rolled steel channels. Shear stud design values shall be taken as per Sections I2.1g and I3.2d(2). Stud connectors shall conform to the requirements of Section A3.6. Channel connectors shall conform to the requirements of Section A3.1.

I2. AXIAL MEMBERS

This section applies to two types of *composite* axial members: encased and filled sections.

1. Encased Composite Columns

1a. Limitations

To qualify as an encased *composite column*, the following limitations shall be met:

- (1) The cross-sectional area of the steel core shall comprise at least 1 percent of the total composite cross section.
- (2) Concrete encasement of the steel core shall be reinforced with continuous longitudinal bars and lateral ties or spirals. The minimum *transverse reinforcement* shall be at least 0.009 in.^2 per in. (6 mm^2 per mm) of tie spacing.
- (3) The minimum reinforcement ratio for continuous longitudinal reinforcing, ρ_{sr} , shall be 0.004, where ρ_{sr} is given by:

$$\rho_{sr} = \frac{A_{sr}}{A_g} \quad (I2-1)$$

where

A_{sr} = area of continuous reinforcing bars, in.^2 (mm^2)

A_g = gross area of composite member, in.^2 (mm^2)

1b. Compressive Strength

The *design compressive strength*, $\phi_c P_n$, and *allowable compressive strength*, P_n/Ω_c , for axially loaded *encased composite columns* shall be determined for the limit state of *flexural buckling* based on column slenderness as follows:

$$\phi_c = 0.75 \text{ (LRFD)} \quad \Omega_c = 2.00 \text{ (ASD)}$$

- (a) When $P_e \geq 0.44P_o$

$$P_n = P_o \left[0.658 \left(\frac{P_o}{P_e} \right) \right] \quad (I2-2)$$

- (b) When $P_e < 0.44P_o$

$$P_n = 0.877P_e \quad (I2-3)$$

where

$$P_o = A_s F_y + A_{sr} F_{yr} + 0.85 A_c f'_c \quad (I2-4)$$

$$P_e = \pi^2 (EI_{eff}) / (KL)^2 \quad (I2-5)$$

and where

A_s = area of the steel section, in.^2 (mm^2)

A_c = area of concrete, in.^2 (mm^2)

A_{sr} = area of continuous reinforcing bars, in.^2 (mm^2)

E_c = modulus of elasticity of concrete = $w_c^{1.5} \sqrt{f'_c}$, ksi ($0.043 w_c^{1.5} \sqrt{f'_c}$, MPa)

E_s = modulus of elasticity of steel = 29,000 ksi (210 MPa)

f'_c = specified compressive strength of concrete, ksi (MPa)

F_y = *specified minimum yield stress* of steel section, ksi (MPa)

F_{yr} = specified minimum yield stress of reinforcing bars, ksi (MPa)

I_c = moment of inertia of the concrete section, in.^4 (mm^4)

I_s = moment of inertia of steel shape, in.^4 (mm^4)

I_{sr} = moment of inertia of reinforcing bars, in.^4 (mm^4)

K = the effective length factor determined in accordance with Chapter C

L = laterally unbraced length of the member, in. (mm)

w_c = weight of concrete per unit volume ($90 \leq w_c \leq 155$ lbs/ft³ or
 $1500 \leq w_c \leq 2500$ kg/m³)

where

EI_{eff} = effective stiffness of composite section, kip-in.² (N-mm²)

$$EI_{eff} = E_s I_s + 0.5 E_s I_{sr} + C_1 E_c I_c \quad (I2-6)$$

where

$$C_1 = 0.1 + 2 \left(\frac{A_s}{A_c + A_s} \right) \leq 0.3 \quad (I2-7)$$

1c. Tensile Strength

The *design tensile strength*, $\phi_t P_n$, and *allowable tensile strength*, P_n/Ω_t , for encased composite columns shall be determined for the limit state of *yielding* as

$$P_n = A_s F_y + A_{sr} F_{yr} \quad (I2-8)$$

$$\phi_t = 0.90 \text{ (LRFD)} \quad \Omega_t = 1.67 \text{ (ASD)}$$

1d. Shear Strength

The *available shear strength* shall be calculated based on either the shear strength of the steel section alone as specified in Chapter G plus the shear strength provided by tie reinforcement, if present, or the shear strength of the reinforced concrete portion alone.

User Note: The nominal shear strength of tie reinforcement may be determined as $A_{st} F_{yr} (d/s)$ where A_{st} is the area of tie reinforcement, d is the effective depth of the concrete section, and s is the spacing of the tie reinforcement. The shear capacity of reinforced concrete may be determined according to ACI 318, Chapter 11.

1e. Load Transfer

Loads applied to axially loaded encased composite columns shall be transferred between the steel and concrete in accordance with the following requirements:

- (a) When the external *force* is applied directly to the steel section, *shear connectors* shall be provided to transfer the required shear force, V' , as follows:

$$V' = V(1 - A_s F_y / P_o) \quad (I2-9)$$

where

V = required shear force introduced to *column*, kips (N)

A_s = area of steel cross section, in.² (mm²)

P_o = nominal axial compressive strength without consideration of *length effects*, kips (N)

- (b) When the external force is applied directly to the concrete encasement, shear connectors shall be provided to transfer the required shear force, V' , as follows:

$$V' = V(A_s F_y / P_o) \quad (I2-10)$$

- (c) When load is applied to the concrete of an encased composite column by direct bearing the *design bearing strength*, $\phi_B P_p$, and the *allowable bearing strength*, P_p/Ω_B , of the concrete shall be:

$$P_p = 1.7 f'_c A_B \quad (\text{I2-11})$$

$$\phi_B = 0.65 \text{ (LRFD)} \quad \Omega_B = 2.31 \text{ (ASD)}$$

where

$$A_B = \text{loaded area of concrete, in.}^2 \text{ (mm}^2\text{)}$$

1f. Detailing Requirements

At least four continuous longitudinal reinforcing bars shall be used in encased composite columns. *Transverse reinforcement* shall be spaced at the smallest of 16 longitudinal bar diameters, 48 tie bar diameters or 0.5 times the least dimension of the composite section. The encasement shall provide at least 1.5 in. (38 mm) of clear cover to the reinforcing steel.

Shear connectors shall be provided to transfer the required shear *force* specified in Section I2.1e. The shear connectors shall be distributed along the length of the member at least a distance of 2.5 times the depth of the encased composite column above and below the load transfer region. The maximum connector spacing shall be 16 in. (405 mm). Connectors to transfer axial load shall be placed on at least two faces of the steel shape in a configuration symmetrical about the steel shape axes.

If the composite cross section is built up from two or more encased steel shapes, the shapes shall be interconnected with *lacing*, *tie plates*, *batten plates* or similar components to prevent buckling of individual shapes due to loads applied prior to hardening of the concrete.

1g. Strength of Stud Shear Connectors

The *nominal strength* of one stud shear connector embedded in solid concrete is:

$$Q_n = 0.5 A_{sc} \sqrt{f'_c E_c} \leq A_{sc} F_u \quad (\text{I2-12})$$

where

A_{sc} = cross-sectional area of stud shear connector, in.² (mm²)

F_u = *specified minimum tensile strength* of a stud shear connector, ksi (MPa)

2. Filled Composite Columns

2a. Limitations

To qualify as a filled *composite column* the following limitations shall be met:

- (1) The cross-sectional area of the steel *HSS* shall comprise at least 1 percent of the total *composite* cross section.
- (2) The maximum *b/t* ratio for a rectangular *HSS* used as a composite column shall be equal to $2.26\sqrt{E/F_y}$. Higher ratios are permitted when their use is justified by testing or analysis.

- (3) The maximum D/t ratio for a round HSS filled with concrete shall be $0.15 E/F_y$. Higher ratios are permitted when their use is justified by testing or analysis.

2b. Compressive Strength

The *design compressive strength*, $\phi_c P_n$, and *allowable compressive strength*, P_n/Ω_c , for axially loaded filled composite columns shall be determined for the *limit state of flexural buckling* based on Section I2.1b with the following modifications:

$$P_o = A_s F_y + A_{sr} F_{yr} + C_2 A_c f'_c \quad (I2-13)$$

$C_2 = 0.85$ for rectangular sections and 0.95 for circular sections

$$EI_{eff} = E_s I_s + E_s I_{sr} + C_3 E_c I_c \quad (I2-14)$$

$$C_3 = 0.6 + 2 \left(\frac{A_s}{A_c + A_s} \right) \leq 0.9 \quad (I2-15)$$

2c. Tensile Strength

The *design tensile strength*, $\phi_t P_n$, and *allowable tensile strength*, P_n/Ω_t , for filled composite columns shall be determined for the *limit state of yielding* as:

$$P_n = A_s F_y + A_{sr} F_{yr} \quad (I2-16)$$

$$\phi_t = 0.90 \text{ (LRFD)} \quad \Omega_t = 1.67 \text{ (ASD)}$$

2d. Shear Strength

The *available shear strength* shall be calculated based on either the shear strength of the steel section alone as specified in Chapter G or the shear strength of the reinforced concrete portion alone.

User Note: The shear strength of reinforced concrete may be determined by ACI 318, Chapter 11.

2e. Load Transfer

Loads applied to filled composite columns shall be transferred between the steel and concrete. When the external force is applied either to the steel section or to the concrete infill, transfer of force from the steel section to the concrete core is required from *direct bond interaction*, *shear connection* or *direct bearing*. The force transfer *mechanism* providing the largest *nominal strength* may be used. These force transfer mechanisms shall not be superimposed.

When load is applied to the concrete of an encased or filled composite column by *direct bearing* the *design bearing strength*, $\phi_B P_p$, and the *allowable bearing strength*, P_p/Ω_B , of the concrete shall be:

$$P_p = 1.7 f'_c A_B \quad (I2-17)$$

$$\phi_B = 0.65 \text{ (LRFD)} \quad \Omega_B = 2.31 \text{ (ASD)}$$

where

A_B is the loaded area, in.² (mm²)

2f. Detailing Requirements

Where required, shear connectors transferring the required shear force shall be distributed along the length of the member at least a distance of 2.5 times the width of a rectangular HSS or 2.5 times the diameter of a round HSS both above and below the load transfer region. The maximum connector spacing shall be 16 in. (405 mm).

I3. FLEXURAL MEMBERS

1. General

1a. Effective Width

The *effective width* of the concrete slab is the sum of the effective widths for each side of the *beam* centerline, each of which shall not exceed:

- (1) one-eighth of the beam span, center-to-center of supports;
- (2) one-half the distance to the centerline of the adjacent beam; or
- (3) the distance to the edge of the slab.

1b. Shear Strength

The available shear strength of *composite beams* with *shear connectors* shall be determined based upon the properties of the steel section alone in accordance with Chapter G. The available shear strength of concrete-encased and filled *composite* members shall be determined based upon the properties of the steel section alone in accordance with Chapter G or based upon the properties of the concrete and longitudinal steel reinforcement.

User Note: The shear strength of the reinforced concrete may be determined in accordance with ACI 318, Chapter 11.

1c. Strength During Construction

When temporary shores are not used during construction, the steel section alone shall have adequate strength to support all *loads* applied prior to the concrete attaining 75 percent of its specified strength f'_c . The available flexural strength of the steel section shall be determined according to Chapter F.

2. Strength of Composite Beams with Shear Connectors

2a. Positive Flexural Strength

The *design positive flexural strength*, $\phi_b M_n$, and the *allowable positive flexural strength*, M_n / Ω_b , shall be determined for the *limit state* of *yielding* as follows:

$$\phi_b = 0.90 \text{ (LRFD)} \quad \Omega_b = 1.67 \text{ (ASD)}$$

- (a) For $h/t_w \leq 3.76\sqrt{E/F_y}$,

M_n shall be determined from the plastic *stress* distribution on the *composite* section for the limit state of *yielding* (*plastic moment*).

User Note: All current ASTM A6 W, S and HP shapes satisfy the limit given in Section I3.2a(a) for $F_y \leq 50$ ksi (345 MPa).

(b) For $h/t_w > 3.76\sqrt{E/F_y}$,

M_n shall be determined from the superposition of elastic stresses, considering the effects of shoring, for the limit state of *yielding* (*yield moment*).

2b. Negative Flexural Strength

The *design negative flexural strength*, $\phi_b M_n$, and the *allowable negative flexural strength*, M_n/Ω_b , shall be determined for the steel section alone, in accordance with the requirements of Chapter F.

Alternatively, the available negative flexural strength shall be determined from the plastic stress distribution on the *composite* section, for the *limit state of yielding* (*plastic moment*), with

$$\phi_b = 0.90 \text{ (LRFD)} \quad \Omega_b = 1.67 \text{ (ASD)}$$

provided that:

- (1) The steel *beam* is *compact* and is adequately braced according to Chapter F.
- (2) *Shear connectors* connect the slab to the steel beam in the negative moment region.
- (3) The slab reinforcement parallel to the steel beam, within the *effective width* of the slab, is *properly developed*.

2c. Strength of Composite Beams with Formed Steel Deck

(1) General

The *available flexural strength* of composite construction consisting of concrete slabs on *formed steel deck* connected to steel beams shall be determined by the applicable portions of Section I3.2a and I3.2b, with the following requirements:

- (a) This section is applicable to decks with *nominal rib height* not greater than 3 in. (75 mm). The average width of concrete rib or haunch, w_r , shall be not less than 2 in. (50 mm), but shall not be taken in calculations as more than the minimum clear width near the top of the steel deck.
- (b) The concrete slab shall be connected to the steel beam with welded stud shear connectors $3/4$ in. (19 mm) or less in diameter (AWS D1.1). Studs shall be welded either through the deck or directly to the steel cross section. Stud shear connectors, after installation, shall extend not less than $1\frac{1}{2}$ in. (38 mm) above the top of the steel deck and there shall be at least $1/2$ in. (13 mm) of concrete cover above the top of the installed studs.
- (c) The slab thickness above the steel deck shall be not less than 2 in. (50 mm).
- (d) Steel deck shall be anchored to all supporting members at a spacing not to exceed 18 in. (460 mm). Such anchorage shall be provided by stud

connectors, a combination of stud connectors and arc spot (puddle) welds, or other devices specified by the designer.

(2) Deck Ribs Oriented Perpendicular to Steel Beam

Concrete below the top of the steel deck shall be neglected in determining composite section properties and in calculating A_c for deck ribs oriented perpendicular to the steel beams.

(3) Deck Ribs Oriented Parallel to Steel Beam

Concrete below the top of the steel deck may be included in determining composite section properties and shall be included in calculating A_c .

Formed steel deck ribs over supporting beams may be split longitudinally and separated to form a *concrete haunch*.

When the nominal depth of steel deck is $1\frac{1}{2}$ in. (38 mm) or greater, the average width, w_r , of the supported haunch or rib shall be not less than 2 in. (50 mm) for the first stud in the transverse row plus four stud diameters for each additional stud.

2d. Shear Connectors

(1) Load Transfer for Positive Moment

The entire *horizontal shear* at the interface between the steel *beam* and the concrete slab shall be assumed to be transferred by shear connectors, except for *concrete-encased beams* as defined in Section I3.3. For *composite* action with concrete subject to flexural compression, the total horizontal shear force, V' , between the point of maximum positive moment and the point of zero moment shall be taken as the lowest value according to the *limit states* of *concrete crushing*, *tensile yielding* of the steel section, or strength of the shear connectors:

(a) Concrete crushing

$$V' = 0.85 f'_c A_c \quad (\text{I3-1a})$$

(b) Tensile yielding of the steel section

$$V' = F_y A_s \quad (\text{I3-1b})$$

(c) Strength of shear connectors

$$V' = \Sigma Q_n \quad (\text{I3-1c})$$

where

A_c = area of concrete slab within *effective width*, in.² (mm²)

A_s = area of steel cross section, in.² (mm²)

ΣQ_n = sum of *nominal strengths* of shear connectors between the point of maximum positive moment and the point of zero moment, kips (N)

(2) Load Transfer for Negative Moment

In continuous *composite beams* where longitudinal reinforcing steel in the negative moment regions is considered to act compositely with the steel *beam*, the total *horizontal shear force* between the point of maximum negative moment

and the point of zero moment shall be taken as the lower value according to the limit states of *yielding* of the steel reinforcement in the slab, or strength of the shear connectors:

(a) Tensile yielding of the slab reinforcement

$$V' = A_r F_{yr} \quad (I3-2a)$$

where

A_r = area of adequately developed longitudinal reinforcing steel within the *effective width* of the concrete slab, in.²(mm²)

F_{yr} = *specified minimum yield stress* of the reinforcing steel, ksi (MPa)

(b) Strength of shear connectors

$$V' = \Sigma Q_n \quad (I3-2b)$$

(3) Strength of Stud Shear Connectors

The *nominal strength* of one stud shear connector embedded in solid concrete or in a *composite* slab is

$$Q_n = 0.5 A_{sc} \sqrt{f'_c E_c} \leq R_g R_p A_{sc} F_u \quad (I3-3)$$

where

A_{sc} = cross-sectional area of stud *shear connector*, in.² (mm²)

E_c = modulus of elasticity of concrete = $w_c^{1.5} \sqrt{f'_c}$, ksi
($0.043 w_c^{1.5} \sqrt{f'_c}$, MPa)

F_u = *specified minimum tensile strength* of a stud shear connector, ksi (MPa)

R_g = 1.0; (a) for one stud welded in a steel deck rib with the deck oriented perpendicular to the steel shape; (b) for any number of studs welded in a row directly to the steel shape; (c) for any number of studs welded in a row through steel deck with the deck oriented parallel to the steel shape and the ratio of the *average rib width* to rib depth ≥ 1.5

= 0.85; (a) for two studs welded in a steel deck rib with the deck oriented perpendicular to the steel shape; (b) for one stud welded through steel deck with the deck oriented parallel to the steel shape and the ratio of the average rib width to rib depth < 1.5

= 0.7 for three or more studs welded in a steel deck rib with the deck oriented perpendicular to the steel shape

R_p = 1.0 for studs welded directly to the steel shape (in other words, not through steel deck or sheet) and having a haunch detail with not more than 50 percent of the top flange covered by deck or sheet steel closures

= 0.75; (a) for studs welded in a *composite* slab with the deck oriented perpendicular to the *beam* and $e_{mid-ht} \geq 2$ in. (50 mm); (b) for studs welded through steel deck, or steel sheet used as *girder filler* material, and embedded in a *composite* slab with the deck oriented parallel to the *beam*

= 0.6 for studs welded in a composite slab with deck oriented perpendicular to the beam and $e_{mid-ht} < 2$ in. (50 mm)

e_{mid-h_t} = distance from the edge of stud shank to the steel deck web, measured at mid-height of the deck rib, and in the *load* bearing direction of the stud (in other words, in the direction of maximum moment for a simply supported beam), in. (mm)

w_c = weight of concrete per unit volume ($90 \leq w_c \leq 155$ lbs/ft³ or $1500 \leq w_c \leq 2500$ kg/m³)

User Note: The table below presents values for R_g and R_p for several cases.

Condition	R_g	R_p
No decking*	1.0	1.0
Decking oriented parallel to the steel shape		
$\frac{w_r}{h_r} \geq 1.5$	1.0	0.75
$\frac{w_r}{h_r} < 1.5$	0.85**	0.75
Decking oriented perpendicular to the steel shape		
Number of studs occupying the same decking rib		
1	1.0	0.6 ⁺
2	0.85	0.6 ⁺
3 or more	0.7	0.6 ⁺

h_r = nominal rib height, in. (mm)

w_r = average width of concrete rib or haunch (as defined in Section I3.2c), in. (mm)

* to qualify as “no decking,” stud shear connectors shall be welded directly to the steel shape and no more than 50 percent of the top flange of the steel shape may be covered by decking or sheet steel, such as girder filler material.

** for a single stud

⁺ this value may be increased to 0.75 when $e_{mid-h_t} \geq 2$ in. (51 mm)

(4) Strength of Channel Shear Connectors

The nominal strength of one channel shear connector embedded in a solid concrete slab is

$$Q_n = 0.3(t_f + 0.5t_w)L_c\sqrt{f'_c E_c} \quad (I3-4)$$

where

t_f = flange thickness of channel shear connector, in. (mm)

t_w = web thickness of channel shear connector, in. (mm)

L_c = length of channel shear connector, in. (mm)

The strength of the channel shear connector shall be developed by welding the channel to the beam flange for a force equal to Q_n , considering eccentricity on the connector.

(5) Required Number of Shear Connectors

The number of shear connectors required between the section of maximum bending moment, positive or negative, and the adjacent section of zero moment shall be equal to the *horizontal shear force* as determined in Sections I3.2d(1) and I3.2d(2) divided by the nominal strength of one shear connector as determined from Section I3.2d(3) or Section I3.2d(4).

(6) Shear Connector Placement and Spacing

Shear connectors required on each side of the point of maximum bending moment, positive or negative, shall be distributed uniformly between that point and the adjacent points of zero moment, unless otherwise specified. However, the number of shear connectors placed between any concentrated *load* and the nearest point of zero moment shall be sufficient to develop the maximum moment required at the *concentrated load* point.

Shear connectors shall have at least 1 in. (25 mm) of lateral concrete cover, except for connectors installed in the ribs of *formed steel decks*. The diameter of studs shall not be greater than 2.5 times the thickness of the flange to which they are welded, unless located over the web. The minimum center-to-center spacing of stud connectors shall be six diameters along the longitudinal axis of the supporting *composite beam* and four diameters transverse to the longitudinal axis of the supporting composite beam, except that within the ribs of formed steel decks oriented perpendicular to the steel beam the minimum center-to-center spacing shall be four diameters in any direction. The maximum center-to-center spacing of shear connectors shall not exceed eight times the total slab thickness nor 36 in.

3. Flexural Strength of Concrete-Encased and Filled Members

The *nominal flexural strength* of concrete-encased and filled members shall be determined using one of the following methods:

- (a) The superposition of elastic *stresses* on the *composite* section, considering the effects of shoring, for the *limit state of yielding (yield moment)*, where

$$\phi_b = 0.90 \text{ (LRFD)} \quad \Omega_b = 1.67 \text{ (ASD)}$$

- (b) The plastic stress distribution on the steel section alone, for the *limit state of yielding (plastic moment)*, where

$$\phi_b = 0.90 \text{ (LRFD)} \quad \Omega_b = 1.67 \text{ (ASD)}$$

- (c) If *shear connectors* are provided and the concrete meets the requirements of Section I1.2, the nominal flexural strength shall be computed based upon

the plastic stress distribution on the composite section or from the strain-compatibility method, where

$$\phi_b = 0.85 \text{ (LRFD)} \quad \Omega_b = 1.76 \text{ (ASD)}$$

I4. COMBINED AXIAL FORCE AND FLEXURE

The interaction between axial forces and flexure in composite members shall account for stability as required by Chapter C. The *design compressive strength*, $\phi_c P_n$, and *allowable compressive strength*, P_n/Ω_c , and the *design flexural strength*, $\phi_b M_n$, and *allowable flexural strength*, M_n/Ω_b , are determined as follows:

$$\phi_c = 0.75 \text{ (LRFD)} \quad \Omega_c = 2.00 \text{ (ASD)}$$

$$\phi_b = 0.90 \text{ (LRFD)} \quad \Omega_b = 1.67 \text{ (ASD)}$$

- (1) The *nominal strength* of the cross section of a *composite* member subjected to combined axial compression and flexure shall be determined using either the *plastic stress distribution method* or the *strain-compatibility method*.
- (2) To account for the influence of length effects on the axial strength of the member, the nominal axial strength of the member shall be determined by Section I2 with P_o taken as the nominal axial strength of the cross section determined in Section I4 (1) above.

I5. SPECIAL CASES

When *composite* construction does not conform to the requirements of Section I1 through Section I4, the strength of *shear connectors* and details of construction shall be established by testing.

CHAPTER J

DESIGN OF CONNECTIONS

This chapter addresses connecting elements, connectors, and the affected elements of the connected members not subject to fatigue *loads*.

The chapter is organized as follows:

- J1. General Provisions
- J2. Welds
- J3. Bolts and Threaded Parts
- J4. Affected Elements of Members and Connecting Elements
- J5. Fillers
- J6. Splices
- J7. Bearing Strength
- J8. Column Bases and Bearing on Concrete
- J9. Anchor Rods and Embedments
- J10. Flanges and Webs with Concentrated Forces

User Note: For cases not included in this chapter, the following sections apply:

- Chapter K. Design of HSS and Box Member Connections
- Appendix 3. Design for Fatigue

J1. GENERAL PROVISIONS

1. Design Basis

The *design strength*, ϕR_n , and the *allowable strength* R_n/Ω , of connections shall be determined in accordance with the provisions of this chapter and the provisions of Chapter B.

The *required strength* of the connections shall be determined by *structural analysis* for the specified *design loads*, consistent with the type of construction specified, or shall be a proportion of the required strength of the connected members when so specified herein.

Where the gravity axes of intersecting axially loaded members do not intersect at one point, the effects of eccentricity shall be considered.

2. Simple Connections

Simple connections of beams, girders, or trusses shall be designed as flexible and are permitted to be proportioned for the reaction shears only, except as otherwise indicated in the design documents. Flexible beam connections shall accommodate

end rotations of simple beams. Some inelastic, but self-limiting deformation in the *connection* is permitted to accommodate the end rotation of a simple beam.

3. Moment Connections

End *connections* of restrained *beams*, girders, and trusses shall be designed for the combined effect of *forces* resulting from moment and shear induced by the rigidity of the connections. Response criteria for moment connections are provided in Section B3.6b.

User Note: See Chapter C and Appendix 7 for analysis requirements to establish the *required strength* and *stiffness* for design of *connections*.

4. Compression Members with Bearing Joints

- (a) When *columns* bear on bearing plates or are finished to bear at *splices*, there shall be sufficient connectors to hold all parts securely in place.
- (b) When compression members other than columns are finished to bear, the splice material and its connectors shall be arranged to hold all parts in line and shall be proportioned for either (i) or (ii) below. It is permissible to use the less severe of the two conditions:
 - (i) An axial tensile *force* of 50 percent of the required compressive strength of the member; or
 - (ii) The moment and shear resulting from a transverse *load* equal to 2 percent of the required compressive strength of the member. The transverse load shall be applied at the location of the splice exclusive of other loads that act on the member. The member shall be taken as pinned for the determination of the shears and moments at the splice.

User Note: All compression *joints* should also be proportioned to resist any tension developed by the *load combinations* stipulated in Section B2.

5. Splices in Heavy Sections

When tensile *forces* due to applied tension or flexure are to be transmitted through *splices* in heavy sections, as defined in Section A3.1c and A3.1d, by complete-joint-penetration groove (CJP) welds, material notch-toughness requirements as given in Section A3.1c and A3.1d, weld access hole details as given in Section J1.6 and thermal cut surface preparation and inspection requirements as given in M2.2 shall apply. The foregoing provision is not applicable to splices of elements of built-up shapes that are welded prior to assembling the shape.

User Note: CJP groove welded splices of heavy sections can exhibit detrimental effects of weld shrinkage. Members that are sized for compression that are also subject to tensile forces may be less susceptible to damage from shrinkage if they are spliced using PJP groove welds on the flanges and fillet-welded web plates or using bolts for some or all of the splice.

6. Beam Copes and Weld Access Holes

All weld access holes required to facilitate welding operations shall have a length from the toe of the weld preparation not less than $1\frac{1}{2}$ times the thickness of the material in which the hole is made. The height of the access hole shall be $1\frac{1}{2}$ times the thickness of the material with the access hole, t_w , but not less than 1 in. (25 mm) nor does it need to exceed 2 in. (50 mm). The access hole shall be detailed to provide room for weld backing as needed.

For sections that are rolled or welded prior to cutting, the edge of the web shall be sloped or curved from the surface of the flange to the *reentrant* surface of the access hole. In hot-rolled shapes, and built-up shapes with CJP *groove welds* that join the web-to-flange, all *beam copes* and weld access holes shall be free of notches and sharp reentrant corners. No arc of the weld access hole shall have a radius less than $\frac{3}{8}$ in. (10 mm).

In built-up shapes with fillet or *partial-joint-penetration groove welds* that join the web-to-flange, all beam copes and weld access holes shall be free of notches and sharp reentrant corners. The access hole shall be permitted to terminate perpendicular to the flange, providing the weld is terminated at least a distance equal to the weld size away from the access hole.

For heavy sections as defined in A3.1c and A3.1d, the *thermally cut* surfaces of beam copes and weld access holes shall be ground to bright metal and inspected by either magnetic particle or dye penetrant methods prior to deposition of *splice welds*. If the curved transition portion of weld access holes and beam copes are formed by predrilled or sawed holes, that portion of the access hole or cope need not be ground. Weld access holes and beam copes in other shapes need not be ground nor inspected by dye penetrant or magnetic particle methods.

7. Placement of Welds and Bolts

Groups of welds or bolts at the ends of any member which transmit axial *force* into that member shall be sized so that the center of gravity of the group coincides with the center of gravity of the member, unless provision is made for the eccentricity. The foregoing provision is not applicable to end connections of statically loaded single angle, double angle, and similar members.

8. Bolts in Combination with Welds

Bolts shall not be considered as sharing the load in combination with welds, except that shear connections with any grade of bolts permitted by Section A3.3 installed in standard holes or short slots transverse to the direction of the load are permitted to be considered to share the load with longitudinally loaded fillet welds. In such connections the available strength of the bolts shall not be taken as greater than 50 percent of the available strength of bearing-type bolts in the connection.

In making welded alterations to structures, existing rivets and high strength bolts tightened to the requirements for *slip-critical connections* are permitted to be

utilized for carrying loads present at the time of alteration and the welding need only provide the additional required strength.

9. High-Strength Bolts in Combination with Rivets

In both new work and alterations, in *connections* designed as *slip-critical connections* in accordance with the provisions of Section J3, high-strength bolts are permitted to be considered as sharing the *load* with existing rivets.

10. Limitations on Bolted and Welded Connections

Pretensioned joints, *slip-critical joints* or welds shall be used for the following *connections*:

- (1) *Column splices* in all multi-story structures over 125 ft (38 m) in height
- (2) Connections of all *beams* and *girders* to columns and any other beams and girders on which the bracing of columns is dependent in structures over 125 ft (38 m) in height
- (3) In all structures carrying cranes of over 5-ton (50 kN) capacity: roof truss splices and connections of trusses to columns, column splices, column bracing, knee braces, and crane supports
- (4) Connections for the support of machinery and other live *loads* that produce impact or reversal of load

Snug-tightened joints or joints with ASTM A307 bolts shall be permitted except where otherwise specified.

J2. WELDS

All provisions of AWS D1.1 apply under this Specification, with the exception that the provisions of the listed AISC Specification Sections apply under this Specification in lieu of the cited AWS provisions as follows:

AISC Specification Section J1.6 in lieu of AWS D1.1 Section 5.17.1

AISC Specification Section J2.2a in lieu of AWS D1.1 Section 2.3.2

AISC Specification Table J2.2 in lieu of AWS D1.1 Table 2.1

AISC Specification Table J2.5 in lieu of AWS D1.1 Table 2.3

AISC Specification Appendix 3, Table A-3.1 in lieu of AWS D1.1 Table 2.4

AISC Specification Section B3.9 and Appendix 3 in lieu of AWS D1.1 Section 2, Part C

AISC Specification Section M2.2 in lieu of AWS D1.1 Sections 5.15.4.3 and 5.15.4.4

1. Groove Welds

1a. Effective Area

The effective area of *groove welds* shall be considered as the length of the weld times the effective throat thickness.

The effective throat thickness of a *complete-joint-penetration (CJP) groove weld* shall be the thickness of the thinner part joined.

TABLE J2.1
Effective Throat of
Partial-Joint-Penetration Groove Welds

Welding Process	Welding Position F (flat), H (horiz.), V (vert.), OH (overhead)	Groove Type (AWS D1.1, Figure 3.3)	Effective Throat
Shielded Metal Arc (SMAW)	All	J or U Groove 60° V	Depth of Groove
Gas Metal Arc (GMAW) Flux Cored Arc (FCAW)	All		
Submerged Arc (SAW)	F	J or U Groove 60° Bevel or V	
Gas Metal Arc (GMAW) Flux Cored Arc (FCAW)	F, H	45° Bevel	Depth of Groove
Shielded Metal Arc (SMAW)	All	45° Bevel	Depth of Groove Minus 1/8 in. (3 mm)
Gas Metal Arc (GMAW) Flux Cored Arc (FCAW)	V, OH	45° Bevel	Depth of Groove Minus 1/8 in. (3 mm)

The effective throat thickness of a *partial-joint-penetration (PJP) groove weld* shall be as shown in Table J2.1.

User Note: The effective throat size of a partial-joint-penetration groove weld is dependent on the process used and the weld position. The contract documents should either indicate the effective throat required or the weld strength required, and the fabricator should detail the *joint* based on the weld process and position to be used to weld the *joint*.

The effective weld size for flare groove welds, when filled flush to the surface of a round bar, a 90° bend in a *formed section*, or rectangular *HSS* shall be as shown in Table J2.2, unless other effective throats are demonstrated by tests. The effective size of flare groove welds filled less than flush shall be as shown in Table J2.2, less the greatest perpendicular dimension measured from a line flush to the base metal surface to the weld surface.

TABLE J2.2
Effective Weld Sizes of
Flare Groove Welds

Welding Process	Flare Bevel Groove ^[a]	Flare V Groove
GMAW and FCAW-G	$\frac{5}{8} R$	$\frac{3}{4} R$
SMAW and FCAW-S	$\frac{5}{16} R$	$\frac{5}{8} R$
SAW	$\frac{5}{16} R$	$\frac{1}{2} R$

^[a]For Flare Bevel Groove with $R < \frac{3}{8}$ in. (10 mm) use only reinforcing fillet weld on filled flush joint.
General Note: R = radius of joint surface (can be assumed to be $2t$ for HSS), in. (mm)

TABLE J2.3
Minimum Effective Throat Thickness of
Partial-Joint-Penetration Groove Welds

Material Thickness of Thinner Part Joined, in. (mm)	Minimum Effective Throat Thickness, ^[a] in. (mm)
To 1/4 (6) inclusive	1/8 (3)
Over 1/4 (6) to 1/2 (13)	3/16 (5)
Over 1/2 (13) to 3/4 (19)	1/4 (6)
Over 3/4 (19) to 1 1/2 (38)	5/16 (8)
Over 1 1/2 (38) to 2 1/4 (57)	3/8 (10)
Over 2 1/4 (57) to 6 (150)	1/2 (13)
Over 6 (150)	5/8 (16)

^[a]See Table J2.1.

Larger effective throat thicknesses than those in Table J2.2 are permitted, provided the fabricator can establish by qualification the consistent production of such larger effective throat thicknesses. Qualification shall consist of sectioning the weld normal to its axis, at mid-length and terminal ends. Such sectioning shall be made on a number of combinations of material sizes representative of the range to be used in the fabrication.

1b. Limitations

The minimum effective throat thickness of a partial-joint-penetration groove weld shall not be less than the size required to transmit calculated *forces* nor the size shown in Table J2.3. Minimum weld size is determined by the thinner of the two parts joined.

2. Fillet Welds

2a. Effective Area

The effective area of a *fillet weld* shall be the *effective length* multiplied by the effective throat. The effective throat of a fillet weld shall be the shortest distance from the root to the face of the diagrammatic weld. An increase in effective throat is permitted if consistent penetration beyond the root of the diagrammatic weld is demonstrated by tests using the production process and procedure variables.

For fillet welds in holes and slots, the effective length shall be the length of the centerline of the weld along the center of the plane through the throat. In the case of overlapping fillets, the effective area shall not exceed the nominal cross-sectional area of the hole or slot, in the plane of the *faying surface*.

2b. Limitations

The minimum size of fillet welds shall be not less than the size required to transmit calculated *forces*, nor the size as shown in Table J2.4. These provisions do not apply to *fillet weld reinforcements* of *partial-* or *complete-joint-penetration groove welds*.

TABLE J2.4	
Minimum Size of Fillet Welds	
Material Thickness of Thinner Part Joined, in. (mm)	Minimum Size of Fillet Weld,^[a] in. (mm)
To 1/4 (6) inclusive	1/8 (3)
Over 1/4 (6) to 1/2 (13)	3/16 (5)
Over 1/2 (13) to 3/4 (19)	1/4 (6)
Over 3/4 (19)	5/16 (8)
^[a] Leg dimension of fillet welds. Single pass welds must be used. Note: See Section J2.2b for maximum size of fillet welds.	

The maximum size of fillet welds of connected parts shall be:

- (a) Along edges of material less than 1/4-in. (6 mm) thick, not greater than the thickness of the material.
- (b) Along edges of material 1/4 in. (6 mm) or more in thickness, not greater than the thickness of the material minus 1/16 in. (2 mm), unless the weld is especially designated on the drawings to be built out to obtain full-throat thickness. In the as-welded condition, the distance between the edge of the base metal and the toe of the weld is permitted to be less than 1/16 in. (2 mm) provided the weld size is clearly verifiable.

The minimum effective length of fillet welds designed on the basis of strength shall be not less than four times the nominal size, or else the size of the weld shall be considered not to exceed 1/4 of its effective length. If longitudinal fillet welds are used alone in end connections of flat-bar tension members, the length of each fillet weld shall be not less than the perpendicular distance between them. For the effect of longitudinal fillet weld length in end connections upon the effective area of the connected member, see Section D3.3.

For end-loaded fillet welds with a length up to 100 times the leg dimension, it is permitted to take the effective length equal to the actual length. When the length of the end-loaded fillet weld exceeds 100 times the weld size, the effective length shall be determined by multiplying the actual length by the reduction factor, β ,

$$\beta = 1.2 - 0.002(L/w) \leq 1.0 \quad (\text{J2-1})$$

where

L = actual length of end-loaded weld, in. (mm)

w = weld leg size, in. (mm)

When the length of the weld exceeds 300 times the leg size, the value of β shall be taken as 0.60.

Intermittent fillet welds are permitted to be used to transfer calculated *stress* across a *joint* or *faying surfaces* when the *required strength* is less than that developed by a continuous fillet weld of the smallest permitted size, and to join components of *built-up members*. The effective length of any segment of intermittent fillet

welding shall be not less than four times the weld size, with a minimum of 1¹/₂ in. (38 mm).

In *lap joints*, the minimum amount of lap shall be five times the thickness of the thinner part joined, but not less than 1 in. (25 mm). Lap joints joining plates or bars subjected to axial *stress* that utilize transverse fillet welds only shall be fillet welded along the end of both lapped parts, except where the deflection of the lapped parts is sufficiently restrained to prevent opening of the joint under maximum loading.

Fillet weld terminations are permitted to be stopped short or extend to the ends or sides of parts or be boxed except as limited by the following:

- (1) For lap joints in which one connected part extends beyond an edge of another connected part that is subject to calculated tensile stress, fillet welds shall terminate not less than the size of the weld from that edge.
- (2) For *connections* where flexibility of the outstanding elements is required, when *end returns* are used, the length of the return shall not exceed four times the nominal size of the weld nor half the width of the part.
- (3) Fillet welds joining *transverse stiffeners* to *plate girder* webs ³/₄ in. (19 mm) thick or less shall end not less than four times nor more than six times the thickness of the web from the web toe of the web-to-flange welds, except where the ends of *stiffeners* are welded to the flange.
- (4) Fillet welds that occur on opposite sides of a common plane, shall be interrupted at the corner common to both welds.

User Note: Fillet weld terminations should be located approximately one weld size from the edge of the connection to minimize notches in the base metal. Fillet welds terminated at the end of the joint, other than those connecting stiffeners to girder webs, are not a cause for correction.

Fillet welds in holes or slots are permitted to be used to transmit shear in lap joints or to prevent the buckling or separation of lapped parts and to join components of built-up members. Such fillet welds may overlap, subject to the provisions of Section J2. Fillet welds in holes or slots are not to be considered plug or *slot welds*.

3. Plug and Slot Welds

3a. Effective Area

The effective shearing area of *plug* and *slot welds* shall be considered as the nominal cross-sectional area of the hole or slot in the plane of the *faying surface*.

3b. Limitations

Plug or slot welds are permitted to be used to transmit shear in *lap joints* or to prevent buckling of lapped parts and to join component parts of *built-up members*.

The diameter of the holes for a plug weld shall not be less than the thickness of the part containing it plus $5/16$ in. (8 mm), rounded to the next larger odd $1/16$ in. (even mm), nor greater than the minimum diameter plus $1/8$ in. (3 mm) or $2^{1/4}$ times the thickness of the weld.

The minimum center-to-center spacing of plug welds shall be four times the diameter of the hole.

The length of slot for a slot weld shall not exceed 10 times the thickness of the weld. The width of the slot shall be not less than the thickness of the part containing it plus $5/16$ in. (8 mm) rounded to the next larger odd $1/16$ in. (even mm), nor shall it be larger than $2^{1/4}$ times the thickness of the weld. The ends of the slot shall be semicircular or shall have the corners rounded to a radius of not less than the thickness of the part containing it, except those ends which extend to the edge of the part.

The minimum spacing of lines of slot welds in a direction transverse to their length shall be four times the width of the slot. The minimum center-to-center spacing in a longitudinal direction on any line shall be two times the length of the slot.

The thickness of plug or slot welds in material $5/8$ in. (16 mm) or less in thickness shall be equal to the thickness of the material. In material over $5/8$ in. (16 mm) thick, the thickness of the weld shall be at least one-half the thickness of the material but not less than $5/8$ in. (16 mm).

4. Strength

The *design strength*, ϕR_n and the *allowable strength*, R_n/Ω , of welds shall be the lower value of the base material and the *weld metal* strength determined according to the *limit states of tensile rupture, shear rupture or yielding* as follows:

For the base metal

$$R_n = F_{BM} A_{BM} \quad (\text{J2-2})$$

For the weld metal

$$R_n = F_w A_w \quad (\text{J2-3})$$

where

F_{BM} = nominal strength of the base metal per unit area, ksi (MPa)

F_w = nominal strength of the weld metal per unit area, ksi (MPa)

A_{BM} = cross-sectional area of the base metal, in.² (mm²)

A_w = effective area of the weld, in.² (mm²)

The values of ϕ , Ω , F_{BM} , and F_w and limitations thereon are given in Table J2.5.

TABLE J2.5
Available Strength of Welded Joints, kips (N)

Load Type and Direction Relative to Weld Axis	Pertinent Metal	ϕ and Ω	Nominal Strength (F_{BM} or F_w) kips (N)	Effective Area (A_{BM} or A_w) in. ² (mm ²)	Required Filler Metal Strength Level ^{[a][b]}
COMPLETE-JOINT-PENETRATION GROOVE WELDS					
Tension Normal to weld axis	Strength of the joint is controlled by the base metal			Matching filler metal shall be used. For T and corner joints with backing left in place, notch tough filler metal is required. See Section J2.6.	
Compression Normal to weld axis	Strength of the joint is controlled by the base metal			Filler metal with a strength level equal to or one strength level less than matching filler metal is permitted.	
Tension or Compression Parallel to weld axis	Tension or compression in parts joined parallel to a weld need not be considered in design of welds joining the parts.			Filler metal with a strength level equal to or less than matching filler metal is permitted.	
Shear	Strength of the joint is controlled by the base metal			Matching filler metal shall be used. ^[c]	
PARTIAL-JOINT-PENETRATION GROOVE WELDS INCLUDING FLARE VEE GROOVE AND FLARE BEVEL GROOVE WELDS					
Tension Normal to weld axis	Base	$\phi = 0.90$ $\Omega = 1.67$	F_y	See J4	Filler metal with a strength level equal to or less than matching filler metal is permitted.
	Weld	$\phi = 0.80$ $\Omega = 1.88$	$0.60 F_{EXX}$	See J2.1a	
Compression Column to Base Plate and column splices designed per J1.4(a)	Compressive stress need not be considered in design of welds joining the parts.				
Compression Connections of members designed to bear other than columns as described in J1.4(b)	Base	$\phi = 0.90$ $\Omega = 1.67$	F_y	See J4	
	Weld	$\phi = 0.80$ $\Omega = 1.88$	$0.60 F_{EXX}$	See J2.1a	
Compression Connections not finished-to-bear	Base	$\phi = 0.90$ $\Omega = 1.67$	F_y	See J4	
	Weld	$\phi = 0.80$ $\Omega = 1.88$	$0.90 F_{EXX}$	See J2.1a	
Tension or Compression Parallel to weld axis	Tension or compression in parts joined parallel to a weld need not be considered in design of welds joining the parts.				
Shear	Base	Governed by J4			
	Weld	$\phi = 0.75$ $\Omega = 2.00$	$0.60 F_{EXX}$	See J2.1a	

TABLE J2.5 (cont.)
Available Strength of Welded Joints, kips (N)

Load Type and Direction Relative to Weld Axis	Pertinent Metal	ϕ and Ω	Nominal Strength (F_{bm} or F_w) kips (N)	Effective Area (A_{EM} or A_w) in. ² (mm ²)	Required Filler Metal Strength Level ^{[a][b]}
FILLET WELDS INCLUDING FILLETS IN HOLES AND SLOTS AND SKEWED T-JOINTS					
Shear	Base	Governed by J4			Filler metal with a strength level equal to or less than matching filler metal is permitted.
	Weld	$\phi = 0.75$ $\Omega = 2.00$	$0.60 F_{EXX}^{[d]}$	See J2.2a	
Tension or Compression Parallel to weld axis	Tension or compression in parts joined parallel to a weld need not be considered in design of welds joining the parts.				
PLUG AND SLOT WELDS					
Shear Parallel to faying surface on the effective area	Base	Governed by J4			Filler metal with a strength level equal to or less than matching filler metal is permitted.
	Weld	$\phi = 0.75$ $\Omega = 2.00$	$0.60 F_{EXX}$	J2.3a	
^[a] For matching weld metal see AWS D1.1, Section 3.3. ^[b] Filler metal with a strength level one strength level greater than matching is permitted. ^[c] Filler metals with a strength level less than matching may be used for groove welds between the webs and flanges of built-up sections transferring shear loads, or in applications where high restraint is a concern. In these applications, the weld joint shall be detailed and the weld shall be designed using the thickness of the material as the effective throat, $\phi = 0.80$, $\Omega = 1.88$ and $0.60 F_{EXX}$ as the nominal strength. ^[d] Alternatively, the provisions of J2.4(a) are permitted provided the deformation compatibility of the various weld elements is considered. Alternatively, Sections J2.4(b) and (c) are special applications of J2.4(a) that provide for deformation compatibility.					

Alternatively, for *fillet welds* loaded in-plane the *design strength*, ϕR_n and the *allowable strength*, R_n/Ω , of welds is permitted to be determined as follows:

$$\phi = 0.75 \text{ (LRFD)} \quad \Omega = 2.00 \text{ (ASD)}$$

(a) For a linear weld group loaded in-plane through the center of gravity

$$R_n = F_w A_w \quad (\text{J2-4})$$

where

$$F_w = 0.60 F_{EXX} (1.0 + 0.50 \sin^{1.5} \theta) \quad (\text{J2-5})$$

and

F_{EXX} = electrode classification number, ksi (MPa)

θ = angle of loading measured from the weld longitudinal axis, degrees

A_w = effective area of the weld, in.² (mm²)

User Note: A linear weld group is one in which all elements are in a line or are parallel.

- (b) For weld elements within a weld group that are loaded in-plane and analyzed using an instantaneous center of rotation method, the components of the *nominal strength*, R_{nx} and R_{ny} , are permitted to be determined as follows:

$$R_{nx} = \sum F_{wix} A_{wi} \quad R_{ny} = \sum F_{wiy} A_{wi} \quad (J2-6)$$

where

A_{wi} = effective area of weld throat of any i th weld element, in.² (mm²)

F_{wi} = $0.60 F_{EXX} (1.0 + 0.50 \sin^{1.5} \theta) f(p)$ (J2-7)

$f(p) = [p(1.9 - 0.9p)]^{0.3}$ (J2-8)

F_{wi} = nominal *stress* in any i th weld element, ksi (MPa)

F_{wix} = x component of stress, F_{wi}

F_{wiy} = y component of stress, F_{wi}

p = Δ_i / Δ_m , ratio of element i deformation to its deformation at maximum stress

w = weld leg size, in. (mm)

r_{crit} = distance from instantaneous center of rotation to weld element with minimum Δ_u / r_i ratio, in. (mm)

Δ_i = deformation of weld elements at intermediate stress levels, linearly proportioned to the critical deformation based on distance from the instantaneous center of rotation, r_i , in. (mm)

= $r_i \Delta_u / r_{crit}$

Δ_m = $0.209(\theta + 2)^{-0.32} w$, deformation of weld element at maximum stress, in. (mm)

Δ_u = $1.087(\theta + 6)^{-0.65} w \leq 0.17w$, deformation of weld element at ultimate stress (fracture), usually in element furthest from instantaneous center of rotation, in. (mm)

- (c) For *fillet weld* groups concentrically loaded and consisting of elements that are oriented both longitudinally and transversely to the direction of applied load, the combined strength, R_n , of the fillet weld group shall be determined as the greater of

$$R_n = R_{wl} + R_{wt} \quad (J2-9a)$$

or

$$R_n = 0.85R_{wl} + 1.5R_{wt} \quad (J2-9b)$$

where

R_{wl} = the total nominal strength of longitudinally loaded fillet welds, as determined in accordance with Table J2.5, kips (N)

R_{wt} = the total nominal strength of transversely loaded fillet welds, as determined in accordance with Table J2.5 without the alternate in Section J2.4(a), kips (N)

5. Combination of Welds

If two or more of the general types of welds (groove, fillet, plug, slot) are combined in a single *joint*, the strength of each shall be separately computed with reference to the axis of the group in order to determine the strength of the combination.

6. Filler Metal Requirements

The choice of electrode for use with *complete-joint-penetration groove welds* subject to tension normal to the effective area shall comply with the requirements for matching *filler metals* given in AWS D1.1.

User Note: The following User Note Table summarizes the AWS D1.1 provisions for matching filler metals. Other restrictions exist. For a complete list of base metals and prequalified matching filler metals see AWS D1.1, Table 3.1.

Base Metal		Matching Filler Metal
A36 \leq 3/4 in. thick		60 & 70 ksi Electrodes
A36 > 3/4 in.	A572 (Gr. 50 & 55) A913 (Gr. 50)	SMAW: E7015, E7016, E7018, E7028
A588* A1011	A992 A1018	Other processes: 70 ksi electrodes
A913 (Gr. 60 & 65)		80 ksi electrodes
* For corrosion resistance and color similar to the base see AWS D1.1, Sect. 3.7.3		
Notes:		
1. Electrodes shall meet the requirements of AWS A5.1, A5.5, A5.17, A5.18, A5.20, A5.23, A5.28 and A5.29.		
2. In joints with base metals of different strengths use either a filler metal that matches the higher strength base metal or a filler metal that matches the lower strength and produces a low hydrogen deposit.		

Filler metal with a specified *Charpy V-Notch* (CVN) toughness of 20 ft-lbs (27 J) at 40 °F (4 °C) shall be used in the following *joints*:

- (1) Complete-joint-penetration groove welded T and corner joints with steel backing left in place, subject to tension normal to the effective area, unless the joints are designed using the *nominal strength* and *resistance factor* or *safety factor* as applicable for a PJP weld.
- (2) Complete-joint-penetration groove welded splices subject to tension normal to the effective area in heavy sections as defined in A3.1c and A3.1d.

The manufacturer's Certificate of Conformance shall be sufficient evidence of compliance.

7. Mixed Weld Metal

When Charpy V-Notch toughness is specified, the process consumables for all *weld metal*, tack welds, root pass and subsequent passes deposited in a *joint* shall be compatible to ensure notch-tough composite weld metal.

J3. BOLTS AND THREADED PARTS

1. High-Strength Bolts

Use of high-strength bolts shall conform to the provisions of the *Specification for Structural Joints Using ASTM A325 or A490 Bolts*, hereafter referred to as the RCSC Specification, as approved by the Research Council on Structural Connections, except as otherwise provided in this Specification.

When assembled, all *joint* surfaces, including those adjacent to the washers, shall be free of scale, except tight *mill scale*. All ASTM A325 or A325M and A490

TABLE J3.1
Minimum Bolt Pretension, kips*

Bolt Size, in.	A325 Bolts	A490 Bolts
1/2	12	15
5/8	19	24
3/4	28	35
7/8	39	49
1	51	64
1 1/8	56	80
1 1/4	71	102
1 3/8	85	121
1 1/2	103	148

*Equal to 0.70 times the minimum *tensile strength* of bolts, rounded off to nearest kip, as specified in ASTM specifications for A325 and A490 bolts with UNC threads.

TABLE J3.1M
Minimum Bolt Pretension, kN*

Bolt Size, mm	A325M Bolts	A490M Bolts
M16	91	114
M20	142	179
M22	176	221
M24	205	257
M27	267	334
M30	326	408
M36	475	595

*Equal to 0.70 times the minimum *tensile strength* of bolts, rounded off to nearest kN, as specified in ASTM specifications for A325M and A490M bolts with UNC threads.

or A490M bolts shall be tightened to a bolt tension not less than that given in Table J3.1 or J3.1M, except as noted below. Except as permitted below, installation shall be assured by any of the following methods: turn-of-nut method, a direct tension indicator, calibrated wrench or alternative design bolt.

Bolts are permitted to be installed to only the snug-tight condition when used in

- (a) *bearing-type connections*.
- (b) tension or combined shear and tension applications, for ASTM A325 or A325M bolts only, where loosening or *fatigue* due to vibration or *load fluctuations* are not design considerations.

The snug-tight condition is defined as the tightness attained by either a few impacts of an impact wrench or the full effort of a worker with an ordinary spud wrench that brings the connected plies into firm contact. Bolts to be tightened only to the snug-tight condition shall be clearly identified on the design and erection drawings.

When ASTM A490 or A490M bolts over 1 in. (25 mm) in diameter are used in slotted or oversized holes in external plies, a single hardened washer conforming to ASTM F436, except with 5/16-in. (8 mm) minimum thickness, shall be used in lieu of the standard washer.

TABLE J3.2
Nominal Stress of Fasteners and Threaded Parts,
ksi (MPa)

Description of Fasteners	Nominal Tensile Stress, F_{nt} , ksi (MPa)	Nominal Shear Stress in Bearing-Type Connections, F_{nv} , ksi (MPa)
A307 bolts	45 (310) ^{[a][b]}	24 (165) ^{[b][c][f]}
A325 or A325M bolts, when threads are not excluded from shear planes	90 (620) ^[e]	48 (330) ^[f]
A325 or A325M bolts, when threads are excluded from shear planes	90 (620) ^[e]	60 (414) ^[f]
A490 or A490M bolts, when threads are not excluded from shear planes	113 (780) ^[e]	60 (414) ^[f]
A490 or A490M bolts, when threads are excluded from shear planes	113 (780) ^[e]	75 (520) ^[f]
Threaded parts meeting the requirements of Section A3.4, when threads are not excluded from shear planes	$0.75 F_u$ ^{[a][d]}	$0.40 F_u$
Threaded parts meeting the requirements of Section A3.4, when threads are excluded from shear planes	$0.75 F_u$ ^{[a][d]}	$0.50 F_u$

^[a]Subject to the requirements of Appendix 3.
^[b]For A307 bolts the tabulated values shall be reduced by 1 percent for each 1/16 in. (2 mm) over 5 diameters of length in the grip.
^[c]Threads permitted in shear planes.
^[d]The nominal tensile strength of the threaded portion of an upset rod, based upon the cross-sectional area at its major thread diameter, A_D , which shall be larger than the nominal body area of the rod before upsetting times F_y .
^[e]For A325 or A325M and A490 or A490M bolts subject to tensile fatigue loading, see Appendix 3.
^[f]When bearing-type connections used to splice tension members have a fastener pattern whose length, measured parallel to the line of force, exceeds 50 in. (1270 mm), tabulated values shall be reduced by 20 percent.

User Note: Washer requirements are provided in the RCSC Specification, Section 6.

In *slip-critical connections* in which the direction of loading is toward an edge of a connected part, adequate available bearing strength shall be provided based upon the applicable requirements of Section J3.10.

When bolt requirements cannot be provided by ASTM A325 and A325M, F1852, or A490 and A490M bolts because of requirements for lengths exceeding 12 diameters or diameters exceeding 1 1/2 in. (38 mm), bolts or threaded rods conforming to ASTM A354 Gr. BC, A354 Gr. BD, or A449 are permitted to be used in accordance with the provisions for threaded rods in Table J3.2.

TABLE J3.3
Nominal Hole Dimensions, in.

Bolt Diameter	Hole Dimensions			
	Standard (Dia.)	Oversize (Dia.)	Short-Slot (Width × Length)	Long-slot (Width × Length)
1/2	9/16	5/8	9/16 × 11/16	9/16 × 11/4
5/8	11/16	13/16	11/16 × 7/8	11/16 × 19/16
3/4	13/16	15/16	13/16 × 1	13/16 × 17/8
7/8	15/16	1 1/16	15/16 × 1 1/8	15/16 × 2 3/16
1	1 1/16	1 1/4	1 1/16 × 1 5/16	1 1/16 × 2 1/2
≥ 1 1/8	$d + 1/16$	$d + 5/16$	$(d + 1/16) \times (d + 3/8)$	$(d + 1/16) \times (2.5 \times d)$

TABLE J3.3M
Nominal Hole Dimensions, mm

Bolt Diameter	Hole Dimensions			
	Standard (Dia.)	Oversize (Dia.)	Short-Slot (Width × Length)	Long-Slot (Width × Length)
M16	18	20	18 × 22	18 × 40
M20	22	24	22 × 26	22 × 50
M22	24	28	24 × 30	24 × 55
M24	27 ^[a]	30	27 × 32	27 × 60
M27	30	35	30 × 37	30 × 67
M30	33	38	33 × 40	33 × 75
≥ M36	$d + 3$	$d + 8$	$(d + 3) \times (d + 10)$	$(d + 3) \times 2.5d$

^[a]Clearance provided allows the use of a 1-in. bolt if desirable.

When ASTM A354 Gr. BC, A354 Gr. BD, or A449 bolts and threaded rods are used in slip-critical connections, the bolt geometry including the head and nut(s) shall be equal to or (if larger in diameter) proportional to that provided by ASTM A325 and A325M, or ASTM A490 and A490M bolts. Installation shall comply with all applicable requirements of the RCSC Specification with modifications as required for the increased diameter and/ or length to provide the design pretension.

2. Size and Use of Holes

The maximum sizes of holes for bolts are given in Table J3.3 or J3.3M, except that larger holes, required for tolerance on location of anchor rods in concrete foundations, are permitted in *column* base details.

Standard holes or *short-slotted holes* transverse to the direction of the *load* shall be provided in accordance with the provisions of this specification, unless oversized holes, short-slotted holes parallel to the load or *long-slotted holes* are approved by the *engineer of record*. Finger *shims* up to 1/4 in. (6 mm) are permitted in *slip-critical connections* designed on the basis of standard holes without reducing the nominal shear strength of the *fastener* to that specified for slotted holes.

Oversized holes are permitted in any or all plies of slip-critical connections, but they shall not be used in *bearing-type connections*. Hardened washers shall be installed over oversized holes in an outer ply.

Short-slotted holes are permitted in any or all plies of slip-critical or bearing-type connections. The slots are permitted without regard to direction of loading in slip-critical connections, but the length shall be normal to the direction of the load in bearing-type connections. Washers shall be installed over short-slotted holes in an outer ply; when high-strength bolts are used, such washers shall be hardened.

Long-slotted holes are permitted in only one of the connected parts of either a slip-critical or bearing-type connection at an individual *faying surface*. Long-slotted holes are permitted without regard to direction of loading in slip-critical connections, but shall be normal to the direction of load in bearing-type connections. Where long-slotted holes are used in an outer ply, plate washers, or a continuous bar with standard holes, having a size sufficient to completely cover the slot after installation, shall be provided. In high-strength bolted connections, such plate washers or continuous bars shall be not less than $5/16$ in. (8 mm) thick and shall be of structural grade material, but need not be hardened. If hardened washers are required for use of high-strength bolts, the hardened washers shall be placed over the outer surface of the plate washer or bar.

3. Minimum Spacing

The distance between centers of standard, oversized, or slotted holes, shall not be less than $2\frac{2}{3}$ times the nominal diameter, d , of the *fastener*; a distance of $3d$ is preferred.

4. Minimum Edge Distance

The distance from the center of a standard hole to an edge of a connected part in any direction shall not be less than either the applicable value from Table J3.4 or J3.4M, or as required in Section J3.10. The distance from the center of an oversized or slotted hole to an edge of a connected part shall be not less than that required for a standard hole to an edge of a connected part plus the applicable increment C_2 from Table J3.5 or J3.5M.

User Note: The edge distances in Tables J3.4 and J3.4M are minimum edge distances based on standard fabrication practices and workmanship tolerances. The appropriate provisions of Sections J3.10 and J4 must be satisfied.

5. Maximum Spacing and Edge Distance

The maximum distance from the center of any bolt or rivet to the nearest edge of parts in contact shall be 12 times the thickness of the connected part under consideration, but shall not exceed 6 in. (150 mm). The longitudinal spacing of fasteners between elements in continuous contact consisting of a plate and a shape or two plates shall be as follows:

TABLE J3.4
Minimum Edge Distance,^[a] in., from
Center of Standard Hole^[b] to Edge of
Connected Part

Bolt Diameter (in.)	At Sheared Edges	At Rolled Edges of Plates, Shapes or Bars, or Thermally Cut Edges ^[c]
1/2	7/8	3/4
5/8	1 1/8	7/8
3/4	1 1/4	1
7/8	1 1/2 ^[d]	1 1/8
1	1 3/4 ^[d]	1 1/4
1 1/8	2	1 1/2
1 1/4	2 1/4	1 5/8
Over 1 1/4	1 3/4 × d	1 1/4 × d

^[a] Lesser edge distances are permitted to be used provided provisions of Section J3.10, as appropriate, are satisfied.

^[b] For oversized or slotted holes, see Table J3.5.

^[c] All edge distances in this *column* are permitted to be reduced 1/8 in. when the hole is at a point where *required strength* does not exceed 25 percent of the maximum strength in the element.

^[d] These are permitted to be 1 1/4 in. at the ends of *beam connection* angles and shear end plates.

TABLE J3.4M
Minimum Edge Distance,^[a] mm, from
Center of Standard Hole^[b] to Edge of
Connected Part

Bolt Diameter (mm)	At Sheared Edges	At Rolled Edges of Plates, Shapes or Bars, or Thermally Cut Edges ^[c]
16	28	22
20	34	26
22	38 ^[d]	28
24	42 ^[d]	30
27	48	34
30	52	38
36	64	46
Over 36	1.75d	1.25d

^[a] Lesser edge distances are permitted to be used provided provisions of Section J3.10, as appropriate, are satisfied.

^[b] For oversized or slotted holes, see Table J3.5M.

^[c] All edge distances in this *column* are permitted to be reduced 3 mm when the hole is at a point where *required strength* does not exceed 25 percent of the maximum strength in the element.

^[d] These are permitted to be 32 mm at the ends of *beam connection* angles and shear end plates.

TABLE J3.5
Values of Edge Distance Increment C_2 , in.

Nominal Diameter of Fastener (in.)	Oversized Holes	Slotted Holes		
		Long Axis Perpendicular to Edge		Long Axis Parallel to Edge
		Short Slots	Long Slots ^[a]	
$\leq 7/8$	$1/16$	$1/8$	$3/4d$	0
1	$1/8$	$1/8$		
$\geq 1 1/8$	$1/8$	$3/16$		

^[a]When length of slot is less than maximum allowable (see Table J3.3), C_2 is permitted to be reduced by one-half the difference between the maximum and actual slot lengths.

TABLE J3.5M
Values of Edge Distance Increment C_2 , mm

Nominal Diameter of Fastener (mm)	Oversized Holes	Slotted Holes		
		Long Axis Perpendicular to Edge		Long Axis Parallel to Edge
		Short Slots	Long Slots ^[a]	
≤ 22	2	3	$0.75d$	0
24	3	3		
≥ 27	3	5		

^[a]When length of slot is less than maximum allowable (see Table J3.3M), C_2 is permitted to be reduced by one-half the difference between the maximum and actual slot lengths.

- (a) For painted members or unpainted members not subject to corrosion, the spacing shall not exceed 24 times the thickness of the thinner plate or 12 in. (305 mm).
- (b) For unpainted members of *weathering steel* subject to atmospheric corrosion, the spacing shall not exceed 14 times the thickness of the thinner plate or 7 in. (180 mm).

6. Tension and Shear Strength of Bolts and Threaded Parts

The *design tension* or *shear strength*, ϕR_n , and the *allowable tension* or *shear strength*, R_n/Ω , of a snug-tightened or pretensioned high-strength bolt or threaded part shall be determined according to the *limit states* of *tensile rupture* and *shear rupture* as follows:

$$R_n = F_n A_b \quad (\text{J3-1})$$

$$\phi = 0.75 \text{ (LRFD)} \quad \Omega = 2.00 \text{ (ASD)}$$

where

F_n = nominal tensile stress F_{nt} , or shear stress, F_{nv} from Table J3.2, ksi (MPa)

A_b = nominal unthreaded body area of bolt or threaded part (for upset rods, see footnote d, Table J3.2), in.² (mm²)

The required *tensile strength* shall include any tension resulting from *prying action* produced by deformation of the connected parts.

7. Combined Tension and Shear in Bearing-Type Connections

The *available tensile strength* of a bolt subjected to combined tension and shear shall be determined according to the *limit states* of *tension* and *shear rupture* as follows:

$$R_n = F'_{nt} A_b \quad (\text{J3-2})$$

$$\phi = 0.75 \text{ (LRFD)} \quad \Omega = 2.00 \text{ (ASD)}$$

where

F'_{nt} = nominal tensile stress modified to include the effects of shearing *stress*, ksi (MPa)

$$F'_{nt} = 1.3 F_{nt} - \frac{F_{nt}}{\phi F_{nv}} f_v \leq F_{nt} \text{ (LRFD)} \quad (\text{J3-3a})$$

$$F'_{nt} = 1.3 F_{nt} - \frac{\Omega F_{nt}}{F_{nv}} f_v \leq F_{nt} \text{ (ASD)} \quad (\text{J3-3b})$$

F_{nt} = nominal tensile stress from Table J3.2, ksi (MPa)

F_{nv} = nominal shear stress from Table J3.2, ksi (MPa)

f_v = the required shear stress, ksi (MPa)

The available shear stress of the *fastener* shall equal or exceed the required shear strength per unit area, f_v .

User Note: Note that when the required *stress*, f , in either shear or tension, is less than or equal to 20 percent of the corresponding available stress, the effects of combined *stress* need not be investigated. Also note that Equations J3-3a and J3-3b can be rewritten so as to find a nominal shear stress, F'_{nv} , as a function of the required tensile *stress*, f_t .

8. High-Strength Bolts in Slip-Critical Connections

High-strength bolts in *slip-critical connections* are permitted to be designed to prevent *slip* either as a serviceability limit state or at the required strength limit state. The connection must also be checked for shear strength in accordance with Sections J3.6 and J3.7 and bearing strength in accordance with Sections J3.1 and J3.10.

Slip-critical connections shall be designed as follows, unless otherwise designated by the *engineer of record*. Connections with standard holes or slots transverse to the direction of the load shall be designed for slip as a serviceability limit state. Connections with oversized holes or slots parallel to the direction of the load shall be designed to prevent slip at the required strength level.

The design slip resistance, ϕR_n , and the allowable slip resistance, R_n/Ω , shall be determined for the *limit state* of slip as follows:

$$R_n = \mu D_u h_{sc} T_b N_s \quad (\text{J3-4})$$

For connections in which prevention of slip is a serviceability limit state

$$\phi = 1.00 \text{ (LRFD)} \quad \Omega = 1.50 \text{ (ASD)}$$

For connections designed to prevent slip at the *required strength* level

$$\phi = 0.85 \text{ (LRFD)} \quad \Omega = 1.76 \text{ (ASD)}$$

where

μ = mean slip coefficient for Class A or B surfaces, as applicable, or as established by tests

= 0.35 for Class A surfaces (unpainted clean mill scale steel surfaces or surfaces with Class A coatings on blast-cleaned steel and hot-dipped galvanized and roughened surfaces)

= 0.50 for Class B surfaces (unpainted blast-cleaned steel surfaces or surfaces with Class B coatings on blast-cleaned steel)

D_u = 1.13; a multiplier that reflects the ratio of the mean installed bolt pretension to the specified minimum bolt pretension. The use of other values may be approved by the *engineer of record*.

h_{sc} = hole factor determined as follows:

(a) For standard size holes $h_{sc} = 1.00$

(b) For oversized and short-slotted holes $h_{sc} = 0.85$

(c) For long-slotted holes $h_{sc} = 0.70$

N_s = number of slip planes

T_b = minimum fastener tension given in Table J3.1, kips, or J3.1M, kN

User Note: There are special cases where, with oversize holes and slots parallel to the load, the movement possible due to connection slip could cause a structural failure. Resistance and safety factors are provided for connections where slip is prevented until the required strength load is reached.

Design loads are used for either design method and all connections must be checked for strength as bearing-type connections.

9. Combined Tension and Shear in Slip-Critical Connections

When a *slip-critical connection* is subjected to an applied tension that reduces the net clamping *force*, the available *slip* resistance per bolt, from Section J3.8, shall be multiplied by the factor, k_s , as follows:

$$k_s = 1 - \frac{T_u}{D_u T_b N_b} \quad \text{(LRFD)} \quad \text{(J3-5a)}$$

$$k_s = 1 - \frac{1.5T_u}{D_u T_b N_b} \quad \text{(ASD)} \quad \text{(J3-5b)}$$

where

N_b = number of bolts carrying the applied tension

T_a = tension force due to *ASD load combinations*, kips (kN)

T_b = minimum *fastener* tension given in Table J3.1 or J3.1M, kips (kN)

T_u = tension force due to *LRFD load combinations*, kips (kN)

10. Bearing Strength at Bolt Holes

The *available bearing strength*, ϕR_n and R_n/Ω , at bolt holes shall be determined for the *limit state of bearing* as follows:

$$\phi = 0.75 \text{ (LRFD)} \quad \Omega = 2.00 \text{ (ASD)}$$

- (a) For a bolt in a *connection* with standard, oversized, and short-slotted holes, independent of the direction of loading, or a long-slotted hole with the slot parallel to the direction of the bearing *force*:

- (i) When deformation at the bolt hole at *service load* is a design consideration

$$R_n = 1.2 L_c t F_u \leq 2.4 dt F_u \quad (\text{J3-6a})$$

- (ii) When deformation at the bolt hole at service load is not a design consideration

$$R_n = 1.5 L_c t F_u \leq 3.0 dt F_u \quad (\text{J3-6b})$$

- (b) For a bolt in a connection with long-slotted holes with the slot perpendicular to the direction of force:

$$R_n = 1.0 L_c t F_u \leq 2.0 dt F_u \quad (\text{J3-6c})$$

- (c) For connections made using bolts that pass completely through an unstiffened box member or *HSS*, see Section J7 and Equation J7-1,

where

d = nominal bolt diameter, in. (mm)

F_u = *specified minimum tensile strength* of the connected material, ksi (MPa)

L_c = clear distance, in the direction of the force, between the edge of the hole and the edge of the adjacent hole or edge of the material, in. (mm)

t = thickness of connected material, in. (mm)

For connections, the bearing resistance shall be taken as the sum of the bearing resistances of the individual bolts.

Bearing strength shall be checked for both bearing-type and *slip-critical connections*. The use of oversized holes and short- and long-slotted holes parallel to the line of force is restricted to slip-critical connections per Section J3.2.

11. Special Fasteners

The *nominal strength* of special fasteners other than the bolts presented in Table J3.2 shall be verified by tests.

12. Tension Fasteners

When bolts or other fasteners in tension are attached to an unstiffened box or *HSS* wall, the strength of the wall shall be determined by rational analysis.

J4. AFFECTED ELEMENTS OF MEMBERS AND CONNECTING ELEMENTS

This section applies to elements of members at *connections* and connecting elements, such as plates, gussets, angles, and brackets.

1. Strength of Elements in Tension

The *design strength*, ϕR_n , and the *allowable strength*, R_n/Ω , of affected and connecting elements loaded in tension shall be the lower value obtained according to the *limit states of tensile yielding* and *tensile rupture*.

(a) For tensile yielding of connecting elements:

$$R_n = F_y A_g \quad (\text{J4-1})$$

$$\phi = 0.90 \text{ (LRFD)} \quad \Omega = 1.67 \text{ (ASD)}$$

(b) For tensile rupture of connecting elements:

$$R_n = F_u A_e \quad (\text{J4-2})$$

$$\phi = 0.75 \text{ (LRFD)} \quad \Omega = 2.00 \text{ (ASD)}$$

where

$A_e = \text{effective net area}$ as defined in Section D3.3, in.² (mm²); for bolted splice plates, $A_e = A_n \leq 0.85 A_g$

2. Strength of Elements in Shear

The available shear yield strength of affected and connecting elements in shear shall be the lower value obtained according to the *limit states of shear yielding* and *shear rupture*:

(a) For shear yielding of the element:

$$R_n = 0.60 F_y A_g \quad (\text{J4-3})$$

$$\phi = 1.00 \text{ (LRFD)} \quad \Omega = 1.50 \text{ (ASD)}$$

(b) For shear rupture of the element:

$$R_n = 0.6 F_u A_{nv} \quad (\text{J4-4})$$

$$\phi = 0.75 \text{ (LRFD)} \quad \Omega = 2.00 \text{ (ASD)}$$

where

$A_{nv} = \text{net area subject to shear, in.}^2 \text{ (mm}^2\text{)}$

3. Block Shear Strength

The *available strength* for the *limit state of block shear rupture* along a shear failure path or path(s) and a perpendicular tension failure path shall be taken as

$$R_n = 0.6 F_u A_{nv} + U_{bs} F_u A_{nt} \leq 0.6 F_y A_{gv} + U_{bs} F_u A_{nt} \quad (\text{J4-5})$$

$$\phi = 0.75 \text{ (LRFD)} \quad \Omega = 2.00 \text{ (ASD)}$$

where

$A_{gv} = \text{gross area subject to shear, in.}^2 \text{ (mm}^2\text{)}$

$A_{nt} = \text{net area subject to tension, in.}^2 \text{ (mm}^2\text{)}$

$A_{nv} = \text{net area subject to shear, in.}^2 \text{ (mm}^2\text{)}$

Where the tension *stress* is uniform, $U_{bs} = 1$; where the tension stress is non-uniform, $U_{bs} = 0.5$.

User Note: The cases where U_{bs} must be taken equal to 0.5 are illustrated in the Commentary.

4. Strength of Elements in Compression

The available strength of connecting elements in compression for the *limit states* of *yielding* and *buckling* shall be determined as follows.

For $KL/r \leq 25$

$$P_n = F_y A_g \quad (J4-6)$$

$$\phi = 0.90 \text{ (LRFD)} \quad \Omega = 1.67 \text{ (ASD)}$$

For $KL/r > 25$ the provisions of Chapter E apply.

J5. FILLERS

In welded construction, any *filler* $1/4$ in. (6 mm) or more in thickness shall extend beyond the edges of the *splice* plate and shall be welded to the part on which it is fitted with sufficient weld to transmit the splice plate *load*, applied at the surface of the filler. The welds joining the splice plate to the filler shall be sufficient to transmit the splice plate load and shall be long enough to avoid overloading the filler along the toe of the weld. Any filler less than $1/4$ in. (6 mm) thick shall have its edges made flush with the edges of the splice plate and the weld size shall be the sum of the size necessary to carry the splice plus the thickness of the filler plate.

When a bolt that carries load passes through fillers that are equal to or less than $1/4$ in. (6 mm) thick, the shear strength shall be used without reduction. When a bolt that carries load passes through fillers that are greater than $1/4$ in. (6 mm) thick, one of the following requirements shall apply:

- (1) For fillers that are equal to or less than $3/4$ in. (19 mm) thick, the shear strength of the bolts shall be multiplied by the factor $[1 - 0.4(t - 0.25)]$ [S.I.: $[1 - 0.0154(t - 6)]]$, where t is the total thickness of the fillers up to $3/4$ in. (19 mm);
- (2) The fillers shall be extended beyond the *joint* and the filler extension shall be secured with enough bolts to uniformly distribute the total *force* in the connected element over the combined cross section of the connected element and the fillers;
- (3) The size of the joint shall be increased to accommodate a number of bolts that is equivalent to the total number required in (2) above; or
- (4) The joint shall be designed to prevent *slip* at required strength levels in accordance with Section J3.8.

J6. SPLICES

Groove-welded *splices* in *plate girders* and *beams* shall develop the *nominal strength* of the smaller spliced section. Other types of splices in cross sections of plate girders and beams shall develop the strength required by the forces at the point of the splice.

J7. BEARING STRENGTH

The *design bearing strength*, ϕR_n , and the *allowable bearing strength*, R_n/Ω , of surfaces in contact shall be determined for the *limit state of bearing (local compressive yielding)* as follows:

$$\phi = 0.75 \text{ (LRFD)} \quad \Omega = 2.00 \text{ (ASD)}$$

The nominal bearing strength, R_n , is defined as follows for the various types of bearing:

- (a) For *milled surfaces*, pins in reamed, drilled, or bored holes, and ends of *fitted bearing stiffeners*:

$$R_n = 1.8F_y A_{pb} \quad (\text{J7-1})$$

where

F_y = specified minimum yield stress, ksi (MPa)

A_{pb} = projected bearing area, in.² (mm²)

- (b) For *expansion rollers* and *rockers*:

- (i) If $d \leq 25$ in. (635 mm)

$$R_n = 1.2(F_y - 13)ld/20 \quad (\text{J7-2})$$

$$\text{(SI: } R_n = 1.2(F_y - 90)ld/20) \quad (\text{J7-2M})$$

- (ii) If $d > 25$ in. (635 mm)

$$R_n = 6.0(F_y - 13)l\sqrt{d}/20 \quad (\text{J7-3})$$

$$\text{(SI: } R_n = 30.2(F_y - 90)l\sqrt{d}/20) \quad (\text{J7-3M})$$

where

d = diameter, in. (mm)

l = length of bearing, in. (mm)

J8. COLUMN BASES AND BEARING ON CONCRETE

Proper provision shall be made to transfer the column loads and moments to the footings and foundations.

In the absence of code regulations, the *design bearing strength*, $\phi_c P_p$, and the *allowable bearing strength*, P_p/Ω_c , for the *limit state of concrete crushing* are

permitted to be taken as follows:

$$\phi_c = 0.60 \text{ (LRFD)} \quad \Omega_c = 2.50 \text{ (ASD)}$$

The nominal bearing strength, P_p , is determined as follows:

(a) On the full area of a concrete support:

$$P_p = 0.85 f'_c A_1 \quad (\text{J8-1})$$

(b) On less than the full area of a concrete support:

$$P_p = 0.85 f'_c A_1 \sqrt{A_2/A_1} \leq 1.7 f'_c A_1 \quad (\text{J8-2})$$

where

A_1 = area of steel concentrically bearing on a concrete support, in.² (mm²)

A_2 = maximum area of the portion of the supporting surface that is geometrically similar to and concentric with the loaded area, in.² (mm²)

J9. ANCHOR RODS AND EMBEDMENTS

Anchor rods shall be designed to provide the required resistance to loads on the completed structure at the base of columns including the net tensile components of any bending moment that may result from load combinations stipulated in Section B2. The anchor rods shall be designed in accordance with the requirements for threaded parts in Table J3.2.

Larger oversized and slotted holes are permitted in base plates when adequate bearing is provided for the nut by using structural or plate washers to bridge the hole.

User Note: The permitted hole sizes and corresponding washer dimensions are given in the *AISC Manual of Steel Construction*.

When horizontal forces are present at *column* bases, these forces should, where possible, be resisted by bearing against concrete elements or by shear friction between the column base plate and the foundation. When anchor rods are designed to resist horizontal force the base plate hole size, the anchor rod setting tolerance, and the horizontal movement of the column shall be considered in the design.

User Note: See ACI 318 for embedment design and for shear friction design. See OSHA for special erection requirements for anchor rods.

J10. FLANGES AND WEBS WITH CONCENTRATED FORCES

This section applies to *single-* and *double-concentrated forces* applied normal to the flange(s) of wide flange sections and similar built-up shapes. A single-concentrated force can be either tensile or compressive. Double-concentrated forces are one tensile and one compressive and form a couple on the same side of the loaded member.

When the *required strength* exceeds the *available strength* as determined for the *limit states* listed in this section, *stiffeners* and/or *doublers* shall be provided and shall be sized for the difference between the required strength and the available strength for the applicable *limit state*. Stiffeners shall also meet the design requirements in Section J10.8. Doublers shall also meet the design requirement in Section J10.9

User Note: See Appendix 6.3 for requirements for the ends of cantilever members.

Stiffeners are required at *unframed ends* of *beams* in accordance with the requirements of Section J10.7.

1. Flange Local Bending

This section applies to tensile *single-concentrated forces* and the tensile component of *double-concentrated forces*.

The *design strength*, ϕR_n , and the *allowable strength*, R_n/Ω , for the *limit state* of flange *local bending* shall be determined as follows:

$$R_n = 6.25t_f^2 F_{yf} \quad (\text{J10-1})$$

$$\phi = 0.90 \text{ (LRFD)} \quad \Omega = 1.67 \text{ (ASD)}$$

where

F_{yf} = specified minimum yield stress of the flange, ksi (MPa)
 t_f = thickness of the loaded flange, in. (mm)

If the length of loading across the member flange is less than $0.15b_f$, where b_f is the member flange width, Equation J10-1 need not be checked.

When the concentrated *force* to be resisted is applied at a distance from the member end that is less than $10t_f$, R_n shall be reduced by 50 percent.

When required, a pair of *transverse stiffeners* shall be provided.

2. Web Local Yielding

This section applies to *single-concentrated forces* and both components of *double-concentrated forces*.

The *available strength* for the *limit state* of web *local yielding* shall be determined as follows:

$$\phi = 1.00 \text{ (LRFD)} \quad \Omega = 1.50 \text{ (ASD)}$$

The *nominal strength*, R_n , shall be determined as follows:

- (a) When the concentrated *force* to be resisted is applied at a distance from the member end that is greater than the depth of the member d ,

$$R_n = (5k + N)F_{yw}t_w \quad (\text{J10-2})$$

- (b) When the concentrated force to be resisted is applied at a distance from the member end that is less than or equal to the depth of the member d ,

$$R_n = (2.5k + N)F_{yw}t_w \quad (\text{J10-3})$$

where

k = distance from outer face of the flange to the web toe of the fillet, in. (mm)

F_{yw} = specified minimum yield stress of the web, ksi (MPa)

N = length of bearing (not less than k for end *beam* reactions), in. (mm)

t_w = web thickness, in. (mm)

When required, a pair of *transverse stiffeners* or a *doubler* plate shall be provided.

3. Web Crippling

This section applies to compressive *single-concentrated forces* or the compressive component of *double-concentrated forces*.

The *available strength* for the *limit state* of *web local crippling* shall be determined as follows:

$$\phi = 0.75 \text{ (LRFD)} \quad \Omega = 2.00 \text{ (ASD)}$$

The *nominal strength*, R_n , shall be determined as follows:

- (a) When the concentrated compressive *force* to be resisted is applied at a distance from the member end that is greater than or equal to $d/2$:

$$R_n = 0.80t_w^2 \left[1 + 3 \left(\frac{N}{d} \right) \left(\frac{t_w}{t_f} \right)^{1.5} \right] \sqrt{\frac{EF_{yw}t_f}{t_w}} \quad (\text{J10-4})$$

- (b) When the concentrated compressive force to be resisted is applied at a distance from the member end that is less than $d/2$:

- (i) For $N/d \leq 0.2$

$$R_n = 0.40t_w^2 \left[1 + 3 \left(\frac{N}{d} \right) \left(\frac{t_w}{t_f} \right)^{1.5} \right] \sqrt{\frac{EF_{yw}t_f}{t_w}} \quad (\text{J10-5a})$$

- (ii) For $N/d > 0.2$

$$R_n = 0.40t_w^2 \left[1 + \left(\frac{4N}{d} - 0.2 \right) \left(\frac{t_w}{t_f} \right)^{1.5} \right] \sqrt{\frac{EF_{yw}t_f}{t_w}} \quad (\text{J10-5b})$$

where

d = overall depth of the member, in. (mm)

t_f = flange thickness, in. (mm)

When required, a *transverse stiffener*, or pair of transverse stiffeners, or a *doubler* plate extending at least one-half the depth of the web shall be provided.

4. Web Sidesway Buckling

This Section applies only to compressive *single-concentrated forces* applied to members where relative lateral movement between the loaded compression flange

and the tension flange is not restrained at the point of application of the concentrated force.

The *available strength* of the web shall be determined as follows:

$$\phi = 0.85 \text{ (LRFD)} \quad \Omega = 1.76 \text{ (ASD)}$$

The *nominal strength*, R_n , for the *limit state* of *web sidesway buckling* shall be determined as follows:

(a) If the compression flange is restrained against rotation:

(i) For $(h/t_w)/(l/b_f) \leq 2.3$

$$R_n = \frac{C_r t_w^3 t_f}{h^2} \left[1 + 0.4 \left(\frac{h/t_w}{l/b_f} \right)^3 \right] \quad (\text{J10-6})$$

(ii) For $(h/t_w)/(l/b_f) > 2.3$, the limit state of web sidesway buckling does not apply.

When the *required strength* of the web exceeds the available strength, local *lateral bracing* shall be provided at the tension flange or either a pair of *transverse stiffeners* or a *doubler plate* shall be provided.

(b) If the compression flange is not restrained against rotation:

(i) For $(h/t_w)/(l/b_f) \leq 1.7$

$$R_n = \frac{C_r t_w^3 t_f}{h^2} \left[0.4 \left(\frac{h/t_w}{l/b_f} \right)^3 \right] \quad (\text{J10-7})$$

(ii) For $(h/t_w)/(l/b_f) > 1.7$, the limit state of web sidesway buckling does not apply.

When the required strength of the web exceeds the available strength, local *lateral bracing* shall be provided at both flanges at the point of application of the concentrated forces.

In Equations J10-6 and J10-7, the following definitions apply:

b_f = flange width, in. (mm)

C_r = 960,000 ksi (6.62×10^6 MPa) when $M_u < M_y$ (LRFD) or $1.5M_u < M_y$ (ASD) at the location of the force
 = 480,000 ksi (3.31×10^6 MPa) when $M_u \geq M_y$ (LRFD) or $1.5M_u \geq M_y$ (ASD) at the location of the force

h = clear distance between flanges less the fillet or corner radius for rolled shapes; distance between adjacent lines of *fasteners* or the clear distance between flanges when welds are used for built-up shapes, in. (mm)

l = largest laterally *unbraced length* along either flange at the point of *load*, in. (mm)

t_f = flange thickness, in. (mm)

t_w = web thickness, in. (mm)

User Note: For determination of adequate restraint, refer to Appendix 6.

5. Web Compression Buckling

This Section applies to a pair of compressive *single-concentrated forces* or the compressive components in a pair of *double-concentrated forces*, applied at both flanges of a member at the same location.

The *available strength* for the *limit state* of web *local buckling* shall be determined as follows:

$$R_n = \frac{24t_w^3 \sqrt{EF_{yw}}}{h} \quad (\text{J10-8})$$

$$\phi = 0.90 \text{ (LRFD)} \quad \Omega = 1.67 \text{ (ASD)}$$

When the pair of concentrated compressive *forces* to be resisted is applied at a distance from the member end that is less than $d/2$, R_n shall be reduced by 50 percent.

When required, a single *transverse stiffener*, a pair of transverse stiffeners, or a *doubler* plate extending the full depth of the web shall be provided.

6. Web Panel Zone Shear

This section applies to *double-concentrated forces* applied to one or both flanges of a member at the same location.

The *available strength* of the web *panel zone* for the *limit state* of *shear yielding* shall be determined as follows:

$$\phi = 0.90 \text{ (LRFD)} \quad \Omega = 1.67 \text{ (ASD)}$$

The *nominal strength*, R_n , shall be determined as follows:

(a) When the effect of panel-zone deformation on frame *stability* is not considered in the analysis:

(i) For $P_r \leq 0.4P_c$

$$R_n = 0.60F_y d_c t_w \quad (\text{J10-9})$$

(ii) For $P_r > 0.4P_c$

$$R_n = 0.60F_y d_c t_w \left(1.4 - \frac{P_r}{P_c} \right) \quad (\text{J10-10})$$

(b) When frame stability, including plastic panel-zone deformation, is considered in the analysis:

(i) For $P_r \leq 0.75P_c$

$$R_n = 0.60F_y d_c t_w \left(1 + \frac{3b_{cf} t_{cf}^2}{d_b d_c t_w} \right) \quad (\text{J10-11})$$

(ii) For $P_r > 0.75P_c$

$$R_n = 0.60F_y d_c t_w \left(1 + \frac{3b_{cf} t_{cf}^2}{d_b d_c t_w} \right) \left(1.9 - \frac{1.2P_r}{P_c} \right) \quad (\text{J10-12})$$

In Equations J10-9 through J10-12, the following definitions apply:

A = column cross-sectional area, in.² (mm²)

b_{cf} = width of column flange, in. (mm)

d_b = beam depth, in. (mm)

d_c = column depth, in. (mm)

F_y = specified minimum yield stress of the column web, ksi (MPa)

P_c = P_y , kips (N) (LRFD)

P_c = $0.6P_y$, kips (N) (ASD)

P_r = required strength, kips (N)

P_y = $F_y A$, axial yield strength of the column, kips (N)

t_{cf} = thickness of the column flange, in. (mm)

t_w = column web thickness, in. (mm)

When required, *doubler* plate(s) or a pair of *diagonal stiffeners* shall be provided within the boundaries of the rigid connection whose webs lie in a common plane.

See Section J10.9 for doubler plate design requirements.

7. Unframed Ends of Beams and Girders

At *unframed ends* of *beams* and *girders* not otherwise restrained against rotation about their longitudinal axes, a pair of *transverse stiffeners*, extending the full depth of the web, shall be provided.

8. Additional Stiffener Requirements for Concentrated Forces

Stiffeners required to resist tensile concentrated *forces* shall be designed in accordance with the requirements of Chapter D and welded to the loaded flange and the web. The welds to the flange shall be sized for the difference between the *required strength* and available *limit state* strength. The stiffener to web welds shall be sized to transfer to the web the algebraic difference in tensile force at the ends of the stiffener.

Stiffeners required to resist compressive concentrated forces shall be designed in accordance with the requirements in Sections E6.2 and J4.4 and shall either bear on or be welded to the loaded flange and welded to the web. The welds to the flange shall be sized for the difference between the required strength and the applicable limit state strength. The weld to the web shall be sized to transfer to the web the algebraic difference in compression force at the ends of the stiffener. For fitted bearing stiffeners, see Section J7.

Transverse full depth bearing stiffeners for compressive forces applied to a *beam* or *plate girder* flange(s) shall be designed as axially compressed members (*columns*) in accordance with the requirements of Sections E6.2 and J4.4.

The member properties shall be determined using an *effective length* of $0.75h$ and a cross section composed of two stiffeners and a strip of the web having a width of $25t_w$ at interior stiffeners and $12t_w$ at the ends of members. The weld connecting full depth bearing stiffeners to the web shall be sized to transmit the difference in compressive force at each of the stiffeners to the web.

Transverse and *diagonal stiffeners* shall comply with the following additional criteria:

- (1) The width of each *stiffener* plus one-half the thickness of the column web shall not be less than one-third of the width of the flange or moment connection plate delivering the concentrated force.
- (2) The thickness of a stiffener shall not be less than one-half the thickness of the flange or moment connection plate delivering the concentrated *load*, and greater than or equal to the width divided by 15.
- (3) *Transverse stiffeners* shall extend a minimum of one-half the depth of the member except as required in J10.5 and J10.7.

9. Additional Doubler Plate Requirements for Concentrated Forces

Doubler plates required for compression strength shall be designed in accordance with the requirements of Chapter E.

Doubler plates required for tensile strength shall be designed in accordance with the requirements of Chapter D.

Doubler plates required for shear strength (see Section J10.6) shall be designed in accordance with the provisions of Chapter G.

In addition, doubler plates shall comply with the following criteria:

- (1) The thickness and extent of the doubler plate shall provide the additional material necessary to equal or exceed the strength requirements.
- (2) The doubler plate shall be welded to develop the proportion of the total force transmitted to the doubler plate.

CHAPTER K

DESIGN OF HSS AND BOX MEMBER CONNECTIONS

This chapter covers member strength design considerations pertaining to connections to HSS members and box sections of uniform wall thickness. See also Chapter J for additional requirements for bolting to HSS.

The chapter is organized as follows:

- K1. Concentrated Forces on HSS
- K2. HSS-to-HSS Truss Connections
- K3. HSS-to-HSS Moment Connections

User Note: See Section J3.10(c) for through-bolts.

K1. CONCENTRATED FORCES ON HSS

1. Definitions of Parameters

B = overall width of rectangular HSS member, measured 90 degrees to the plane of the *connection*, in. (mm)

B_p = width of plate, measured 90 degrees to the plane of the connection, in. (mm)

D = outside diameter of round HSS member, in. (mm)

F_y = *specified minimum yield stress* of HSS member material, ksi (MPa)

F_{yp} = specified minimum yield stress of plate, ksi (MPa)

F_u = *specified minimum tensile strength* of HSS material, ksi (MPa)

H = overall height of rectangular HSS member, measured in the plane of the connection, in. (mm)

N = bearing length of the *load*, measured parallel to the axis of the HSS member, (or measured across the width of the HSS in the case of loaded cap plates), in. (mm)

t = *design wall thickness* of HSS member, in. (mm)

t_p = thickness of plate, in. (mm)

2. Limits of Applicability

The criteria herein are applicable only when the *connection* configuration is within the following limits of applicability:

- (1) Strength: $F_y \leq 52$ ksi (360 MPa) for HSS
- (2) Ductility: $F_y/F_u \leq 0.8$ for HSS
- (3) Other limits apply for specific criteria

3. Concentrated Force Distributed Transversely

3a. Criterion for Round HSS

When a concentrated *force* is distributed transversely to the axis of the *HSS* the *design strength*, ϕR_n , and the *allowable strength*, R_n/Ω , for the *limit state* of *local yielding* shall be determined as follows:

$$R_n = F_y t^2 [5.5 / (1 - 0.81 B_p / D)] Q_f \quad (\text{K1-1})$$

$$\phi = 0.90 \text{ (LRFD)} \quad \Omega = 1.67 \text{ (ASD)}$$

where Q_f is given by Equation K2-1.

Additional limits of applicability are

$$(1) 0.2 < B_p / D \leq 1.0$$

$$(2) D/t \leq 50 \text{ for } T\text{-connections and } D/t \leq 40 \text{ for } \textit{cross-connections}$$

3b. Criteria for Rectangular HSS

When a concentrated force is distributed transversely to the axis of the HSS the design strength, ϕR_n , and the allowable strength, R_n/Ω , shall be the lowest value according to the limit states of local yielding due to *uneven load distribution*, *shear yielding (punching)* and *sidewall strength*.

Additional limits of applicability are

$$(1) 0.25 < B_p / B \leq 1.0$$

$$(2) B/t \text{ for the loaded HSS wall } \leq 35$$

(a) For the limit state of local yielding due to uneven load distribution in the loaded plate,

$$R_n = [10 F_y t / (B/t)] B_p \leq F_{yp} t_p B_p \quad (\text{K1-2})$$

$$\phi = 0.95 \text{ (LRFD)} \quad \Omega = 1.58 \text{ (ASD)}$$

(b) For the limit state of shear yielding (punching),

$$R_n = 0.6 F_y t [2t_p + 2B_{ep}] \quad (\text{K1-3})$$

$$\phi = 0.95 \text{ (LRFD)} \quad \Omega = 1.58 \text{ (ASD)}$$

where

$$B_{ep} = 10 B_p / (B/t) \leq B_p$$

This limit state need not be checked when $B_p > (B - 2t)$, nor when $B_p < 0.85B$.

(c) For the limit state of sidewall under tension loading, the available strength shall be taken as the strength for sidewall local yielding. For the limit state of sidewall under compression loading, available strength shall be taken as the

lowest value obtained according to the limit states of sidewall local yielding, sidewall local crippling and sidewall local buckling.

This limit state need not be checked unless the *chord member* and *branch member* (connecting element) have the same width ($\beta = 1.0$).

- (i) For the limit state of sidewall local yielding,

$$R_n = 2F_y t [5k + N] \quad (\text{K1-4})$$

$$\phi = 1.0 \text{ (LRFD)} \quad \Omega = 1.50 \text{ (ASD)}$$

where

k = outside corner radius of the HSS, which is permitted to be taken as $1.5t$ if unknown, in. (mm)

- (ii) For the limit state of sidewall local crippling, in T-connections,

$$R_n = 1.6t^2 [1 + 3N/(H - 3t)] (EF_y)^{0.5} Q_f \quad (\text{K1-5})$$

$$\phi = 0.75 \text{ (LRFD)} \quad \Omega = 2.0 \text{ (ASD)}$$

where Q_f is given by Equation K2-10.

- (iii) For the limit state of sidewall local buckling in cross-connections,

$$R_n = [48t^3/(H - 3t)] (EF_y)^{0.5} Q_f \quad (\text{K1-6})$$

$$\phi = 0.90 \text{ (LRFD)} \quad \Omega = 1.67 \text{ (ASD)}$$

where Q_f is given by Equation K2-10.

The nonuniformity of load transfer along the line of weld, due to the flexibility of the HSS wall in a transverse plate-to-HSS connection, shall be considered in proportioning such welds. This requirement can be satisfied by limiting the total effective weld length, L_e , of groove and fillet welds to rectangular HSS as follows:

$$L_e = 2[10/(B/t)] [(F_y t)/(F_{yp} t_p)] B_p \leq 2B_p \quad (\text{K1-7})$$

where

L_e = total effective weld length for welds on both sides of the transverse plate, in. (mm)

In lieu of Equation K1-7, this requirement may be satisfied by other rational approaches.

User Note: An upper limit on weld size will be given by the weld that develops the available strength of the connected element.

4. Concentrated Force Distributed Longitudinally at the Center of the HSS Diameter or Width, and Acting Perpendicular to the HSS Axis

When a concentrated *force* is distributed longitudinally along the axis of the HSS at the center of the HSS diameter or width, and also acts perpendicular to the axis direction of the HSS (or has a component perpendicular to the axis direction of the

HSS), the *design strength*, ϕR_n , and the *allowable strength*, R_n/Ω , perpendicular to the HSS axis shall be determined for the *limit state of chord plastification* as follows.

4a. Criterion for Round HSS

An additional limit of applicability is:

$D/t \leq 50$ for *T-connections* and $D/t \leq 40$ for *cross-connections*

$$R_n = 5.5 F_y t^2 (1 + 0.25 N/D) Q_f \quad (\text{K1-8})$$

$$\phi = 0.90 \text{ (LRFD)} \quad \Omega = 1.67 \text{ (ASD)}$$

where Q_f is given by Equation K2-1.

4b. Criterion for Rectangular HSS

An additional limit of applicability is:

B/t for the loaded HSS wall ≤ 40

$$R_n = [F_y t^2 / (1 - t_p/B)] [2N/B + 4(1 - t_p/B)^{0.5}] Q_f \quad (\text{K1-9})$$

$$\phi = 1.00 \text{ (LRFD)} \quad \Omega = 1.50 \text{ (ASD)}$$

where

$$Q_f = (1 - U^2)^{0.5}$$

U is given by Equation K2-12

5. Concentrated Force Distributed Longitudinally at the Center of the HSS Width, and Acting Parallel to the HSS Axis

When a concentrated *force* is distributed longitudinally along the axis of a rectangular *HSS*, and also acts parallel but eccentric to the axis direction of the member, the *connection* shall be verified as follows:

$$F_{yp} t_p \leq F_u t \quad (\text{K1-10})$$

User Note: This provision is primarily intended for shear tab connections. Equation K1-10 precludes shear yielding (punching) of the HSS wall by requiring the plate (shear tab) strength to be less than the HSS wall strength. For bracing connections to HSS columns, where a load is applied by a longitudinal plate at an angle to the HSS axis, the connection design will be governed by the force component perpendicular to the HSS axis (see Section K1.4b).

6. Concentrated Axial Force on the End of a Rectangular HSS with a Cap Plate

When a concentrated *force* acts on the end of a capped *HSS*, and the force is in the direction of the HSS axis, the *design strength*, ϕR_n , and the *allowable strength*, R_n/Ω , shall be determined for the *limit states* of wall *local yielding* (due to tensile or compressive *forces*) and wall *local crippling* (due to compressive forces only), with consideration for shear lag, as follows.

User Note: The procedure below presumes that the concentrated *force* has a dispersion slope of 2.5:1 through the cap plate (of thickness t_p) and disperses into the two HSS walls of dimension B .

If $(5t_p + N) \geq B$, the *available strength* of the HSS is computed by summing the contributions of all four HSS walls.

If $(5t_p + N) < B$, the available strength of the HSS is computed by summing the contributions of the two walls into which the *load* is distributed.

(i) For the limit state of wall local yielding, for one wall,

$$R_n = F_y t [5t_p + N] \leq B F_y t \quad (\text{K1-11})$$

$$\phi = 1.00 \text{ (LRFD)} \quad \Omega = 1.50 \text{ (ASD)}$$

(ii) For the limit state of wall local crippling, for one wall,

$$R_n = 0.8t^2 [1 + (6N/B)(t/t_p)^{1.5}] [E F_y t_p / t]^{0.5} \quad (\text{K1-12})$$

$$\phi = 0.75 \text{ (LRFD)} \quad \Omega = 2.00 \text{ (ASD)}$$

K2. HSS-TO-HSS TRUSS CONNECTIONS

HSS-to-HSS truss connections are defined as connections that consist of one or more *branch members* that are directly welded to a continuous chord that passes through the connection and shall be classified as follows:

- (a) When the *punching load* ($P_r \sin \theta$) in a branch member is equilibrated by *beam shear* in the *chord member*, the connection shall be classified as a *T-connection* when the branch is perpendicular to the chord and a *Y-connection* otherwise.
- (b) When the punching load ($P_r \sin \theta$) in a branch member is essentially equilibrated (within 20 percent) by *loads* in other branch member(s) on the same side of the connection, the connection shall be classified as a *K-connection*. The relevant gap is between the primary branch members whose loads equilibrate. An *N-connection* can be considered as a type of K-connection.

User Note: A K-connection with one branch perpendicular to the chord is often called an N-connection.

- (c) When the punching load ($P_r \sin \theta$) is transmitted through the chord member and is equilibrated by branch member(s) on the opposite side, the connection shall be classified as a *cross-connection*.
- (d) When a connection has more than two primary branch members, or branch members in more than one plane, the connection shall be classified as a general or multiplanar connection.

When branch members transmit part of their load as K-connections and part of their load as T-, Y-, or cross-connections, the *nominal strength* shall be determined by interpolation on the proportion of each in total.

For the purposes of this Specification, the centerlines of branch members and chord members shall lie in a common plane. Rectangular HSS connections are further limited to have all members oriented with walls parallel to the plane. For trusses that are made with HSS that are connected by welding branch members to chord members, eccentricities within the limits of applicability are permitted without consideration of the resulting moments for the design of the connection.

1. Definitions of Parameters

B = overall width of rectangular HSS main member, measured 90 degrees to the plane of the connection, in. (mm)

B_b = overall width of rectangular HSS branch member, measured 90 degrees to the plane of the connection, in. (mm)

D = outside diameter of round HSS main member, in. (mm)

D_b = outside diameter of round HSS branch member, in. (mm)

e = eccentricity in a truss connection, positive being away from the branches, in. (mm)

F_y = *specified minimum yield stress* of HSS main member material, ksi (MPa)

F_{yb} = *specified minimum yield stress* of HSS branch member material, ksi (MPa)

F_u = *specified minimum tensile strength* of HSS material, ksi (MPa)

g = gap between toes of branch members in a gapped K-connection, neglecting the welds, in. (mm)

H = overall height of rectangular HSS main member, measured in the plane of the connection, in. (mm)

H_b = overall height of rectangular HSS branch member, measured in the plane of the connection, in. (mm)

t = *design wall thickness* of HSS main member, in. (mm)

t_b = *design wall thickness* of HSS branch member, in. (mm)

β = the width ratio; the ratio of branch diameter to chord diameter = D_b/D for round HSS; the ratio of overall branch width to chord width = B_b/B for rectangular HSS

β_{eff} = the *effective width* ratio; the sum of the perimeters of the two branch members in a K-connection divided by eight times the chord width

γ = the chord slenderness ratio; the ratio of one-half the diameter to the wall thickness = $D/2t$ for round HSS; the ratio of one-half the width to wall thickness = $B/2t$ for rectangular HSS

η = the *load length* parameter, applicable only to rectangular HSS; the ratio of the length of contact of the branch with the chord in the plane of the connection to the chord width = N/B , where $N = H_b/\sin\theta$

θ = acute angle between the branch and chord (degrees)

ζ = the gap ratio; the ratio of the gap between the branches of a gapped K-connection to the width of the chord = g/B for rectangular HSS

2. Criteria for Round HSS

The interaction of *stress* due to *chord member forces* and local branch connection forces shall be incorporated through the chord-stress interaction parameter Q_f .

When the chord is in tension,

$$Q_f = 1$$

When the chord is in compression,

$$Q_f = 1.0 - 0.3U(1 + U) \quad (\text{K2-1})$$

where U is the utilization ratio given by

$$U = |P_r/A_g F_c + M_r/SF_c| \quad (\text{K2-2})$$

and

P_r = required axial strength in chord, kips (N); for K-connections, P_r is to be determined on the side of the *joint* that has the lower compression stress (lower U)

M_r = required flexural strength in chord, kip-in. (N-mm)

A_g = chord gross area, in.² (mm²)

F_c = *available stress*, ksi (MPa)

S = chord elastic section modulus, in.³ (mm³)

For design according to Section B3.3 (LRFD):

$P_r = P_u$ = required axial strength in chord, using *LRFD load combinations*, kips (N)

$M_r = M_u$ = required flexural strength in chord, using LRFD load combinations, kip-in. (N-mm)

$F_c = F_y$, ksi (MPa)

For design according to Section B3.4 (ASD):

$P_r = P_a$ = required axial strength in chord, using *ASD load combinations*, kips (N)

$M_r = M_a$ = required flexural strength in chord, using ASD load combinations, kip-in. (N-mm)

$F_c = 0.6 F_y$, ksi (MPa)

2a. Limits of Applicability

The criteria herein are applicable only when the *connection* configuration is within the following limits of applicability:

- (1) *Joint eccentricity*: $-0.55D \leq e \leq 0.25D$, where D is the chord diameter and e is positive away from the branches
- (2) *Branch angle*: $\theta \geq 30^\circ$
- (3) *Chord wall slenderness*: ratio of diameter to wall thickness less than or equal to 50 for *T*-, *Y*- and *K*-connections; less than or equal to 40 for *cross-connections*

- (4) Tension branch wall slenderness: ratio of diameter to wall thickness less than or equal to 50
- (5) Compression branch wall slenderness: ratio of diameter to wall thickness less than or equal to $0.05E/F_y$
- (6) Width ratio: $0.2 < D_b/D \leq 1.0$ in general, and $0.4 \leq D_b/D \leq 1.0$ for gapped K-connections
- (7) If a *gap connection*: g greater than or equal to the sum of the branch wall thicknesses
- (8) If an *overlap connection*: $25\% \leq O_v \leq 100\%$, where $O_v = (q/p) \times 100\%$. p is the projected length of the overlapping branch on the chord; q is the overlap length measured along the connecting face of the chord beneath the two branches. For overlap connections, the larger (or if equal diameter, the thicker) branch is a “thru member” connected directly to the chord.
- (9) Branch thickness ratio for overlap connections: thickness of overlapping branch to be less than or equal to the thickness of the overlapped branch
- (10) Strength: $F_y \leq 52$ ksi (360 MPa) for chord and branches
- (11) Ductility: $F_y / F_u \leq 0.8$

2b. Branches with Axial Loads in T-, Y- and Cross-Connections

For T- and Y- connections, the *design strength* of the branch ϕP_n , or the *allowable strength* of the branch, P_n/Ω , shall be the lower value obtained according to the *limit states* of *chord plastification* and *shear yielding (punching)*.

- (a) For the limit state of chord plastification in T- and Y-connections,

$$\begin{aligned} P_n \sin \theta &= F_y t^2 [3.1 + 15.6\beta^2] \gamma^{0.2} Q_f & (K2-3) \\ \phi &= 0.90 \text{ (LRFD)} & \Omega = 1.67 \text{ (ASD)} \end{aligned}$$

- (b) For the limit state of shear yielding (punching),

$$\begin{aligned} P_n &= 0.6 F_y t \pi D_b [(1 + \sin \theta) / 2 \sin^2 \theta] & (K2-4) \\ \phi &= 0.95 \text{ (LRFD)} & \Omega = 1.58 \text{ (ASD)} \end{aligned}$$

This limit state need not be checked when $\beta > (1 - 1/\gamma)$.

- (c) For the limit state of chord plastification in cross-connections,

$$\begin{aligned} P_n \sin \theta &= F_y t^2 [5.7 / (1 - 0.81\beta)] Q_f & (K2-5) \\ \phi &= 0.90 \text{ (LRFD)} & \Omega = 1.67 \text{ (ASD)} \end{aligned}$$

2c. Branches with Axial Loads in K-Connections

For K-connections, the design strength of the branch, ϕP_n , and the allowable strength of the branch, P_n/Ω , shall be the lower value obtained according to the limit states of chord plastification for gapped and overlapped connections and shear yielding (punching) for gapped connections only.

- (a) For the limit state of chord plastification,

$$\phi = 0.90 \text{ (LRFD)} \quad \Omega = 1.67 \text{ (ASD)}$$

For the compression branch:

$$P_n \sin\theta = F_y t^2 [2.0 + 11.33 D_b / D] Q_g Q_f \quad (\text{K2-6})$$

where D_b refers to the compression branch only, and

$$Q_g = \gamma^{0.2} \left[1 + \frac{0.024 \gamma^{1.2}}{e^{\left(\frac{0.5g}{r} - 1.33\right)} + 1} \right] \quad (\text{K2-7})$$

In gapped connections, g (measured along the crown of the chord neglecting weld dimensions) is positive. In overlapped connections, g is negative and equals q .

For the tension branch,

$$P_n \sin\theta = (P_n \sin\theta)_{\text{compression branch}} \quad (\text{K2-8})$$

(b) For the limit state of shear yielding (punching) in gapped K-connections,

$$\begin{aligned} P_n &= 0.6 F_y t \pi D_b [(1 + \sin\theta) / 2 \sin^2\theta] \quad (\text{K2-9}) \\ \phi &= 0.95 \text{ (LRFD)} \quad \Omega = 1.58 \text{ (ASD)} \end{aligned}$$

3. Criteria for Rectangular HSS

The interaction of *stress* due to *chord member forces* and local branch connection forces shall be incorporated through the chord-stress interaction parameter Q_f .

When the chord is in tension,

$$Q_f = 1$$

When the chord is in compression in T -, Y -, and *cross-connections*,

$$Q_f = 1.3 - 0.4U / \beta \leq 1 \quad (\text{K2-10})$$

When the chord is in compression in gapped K -connections,

$$Q_f = 1.3 - 0.4U / \beta_{\text{eff}} \leq 1 \quad (\text{K2-11})$$

where U is the utilization ratio given by

$$U = |P_r / A_g F_c + M_r / S F_c| \quad (\text{K2-12})$$

and

P_r = required axial strength in chord, kips (N). For gapped K-connections, P_r is to be determined on the side of the *joint* that has the higher compression stress (higher U).

M_r = required flexural strength in chord, kip-in. (N-mm)

A_g = chord gross area, in.² (mm²)

F_c = available stress, ksi (MPa)

S = chord elastic section modulus, in.³ (mm³)

For design according to Section B3.3 (LRFD):

$P_r = P_u$ = required axial strength in chord, using *LRFD load combinations*, kips (N)

$M_r = M_u$ = required flexural strength in chord, using LRFD load combinations, kip-in. (N-mm)

$F_c = F_y$, ksi (MPa)

For design according to Section B3.4 (ASD):

$P_r = P_a$ = required axial strength in chord, using *ASD load combinations*, kips, (N)

$M_r = M_a$ = required flexural strength in chord, using ASD load combinations, kip-in. (N-mm)

$F_c = 0.6F_y$, ksi, (MPa)

3a. Limits of Applicability

The criteria herein are applicable only when the *connection* configuration is within the following limits:

- (1) *Joint eccentricity*: $-0.55H \leq e \leq 0.25H$, where H is the chord depth and e is positive away from the branches
- (2) Branch angle: $\theta \geq 30^\circ$
- (3) Chord wall slenderness: ratio of overall wall width to thickness less than or equal to 35 for gapped K-connections and T-, Y- and cross-connections; less than or equal to 30 for overlapped K-connections
- (4) Tension branch wall slenderness: ratio of overall wall width to thickness less than or equal to 35
- (5) Compression branch wall slenderness: ratio of overall wall width to thickness less than or equal to $1.25(E/F_{yb})^{0.5}$ and also less than 35 for gapped K-connections and T-, Y- and cross-connections; less than or equal to $1.1(E/F_{yb})^{0.5}$ for overlapped K-connections
- (6) Width ratio: ratio of overall wall width of branch to overall wall width of chord greater than or equal to 0.25 for T-, Y-, cross- and overlapped K-connections; greater than or equal to 0.35 for gapped K-connections
- (7) Aspect ratio: $0.5 \leq$ ratio of depth to width ≤ 2.0
- (8) Overlap: $25\% \leq O_v \leq 100\%$, where $O_v = (q/p) \times 100\%$. p is the projected length of the overlapping branch on the chord; q is the overlap length measured along the connecting face of the chord beneath the two branches. For overlap connections, the larger (or if equal width, the thicker) branch is a "thru member" connected directly to the chord
- (9) Branch width ratio for *overlap connections*: ratio of overall wall width of overlapping branch to overall wall width of overlapped branch greater than or equal to 0.75
- (10) Branch thickness ratio for overlap connections: thickness of overlapping branch to be less than or equal to the thickness of the overlapped branch

- (11) Strength: $F_y \leq 52$ ksi (360 MPa) for chord and branches
 (12) Ductility: $F_y/F_u \leq 0.8$
 (13) Other limits apply for specific criteria

3b. Branches with Axial Loads in T-, Y- and Cross-Connections

For T-, Y-, and cross-connections, the *design strength* of the branch, ϕP_n , or the *allowable strength* of the branch, P_n/Ω , shall be the lowest value obtained according to the *limit states* of *chord wall plastification*, *shear yielding (punching)*, *sidewall strength* and *local yielding* due to *uneven load distribution*. In addition to the limits of applicability in Section K2.3a, β shall not be less than 0.25.

- (a) For the limit state of chord wall plastification,

$$P_n \sin \theta = F_y t^2 [2\eta / (1 - \beta) + 4 / (1 - \beta)^{0.5}] Q_f \quad (\text{K2-13})$$

$$\phi = 1.00 \text{ (LRFD)} \quad \Omega = 1.50 \text{ (ASD)}$$

This limit state need not be checked when $\beta > 0.85$.

- (b) For the limit state of shear yielding (punching),

$$P_n \sin \theta = 0.6 F_y t B [2\eta + 2\beta_{eop}] \quad (\text{K2-14})$$

$$\phi = 0.95 \text{ (LRFD)} \quad \Omega = 1.58 \text{ (ASD)}$$

In Equation K2-14, the effective outside punching parameter $\beta_{eop} = 5\beta/\gamma$ shall not exceed β .

This limit state need not be checked when $\beta > (1 - 1/\gamma)$, nor when $\beta < 0.85$ and $B/t \geq 10$.

- (c) For the limit state of sidewall strength, the *available strength* for branches in tension shall be taken as the available strength for sidewall local yielding. For the limit state of sidewall strength, the available strength for branches in compression shall be taken as the lower of the strengths for sidewall local yielding and sidewall local crippling. For cross-connections with a branch angle less than 90 degrees, an additional check for chord sidewall shear failure must be made in accordance with Section G5.

This limit state need not be checked unless the chord member and branch member have the same width ($\beta = 1.0$).

- (i) For the limit state of local yielding,

$$P_n \sin \theta = 2F_y t [5k + N] \quad (\text{K2-15})$$

$$\phi = 1.00 \text{ (LRFD)} \quad \Omega = 1.50 \text{ (ASD)}$$

where

k = outside corner radius of the HSS, which is permitted to be taken as $1.5t$ if unknown, in. (mm)

N = bearing length of the *load*, parallel to the axis of the HSS main member, $H_b/\sin\theta$, in. (mm)

(ii) For the limit state of sidewall local crippling, in T- and Y-connections,

$$P_n \sin \theta = 1.6t^2[1 + 3N/(H - 3t)](EF_y)^{0.5} Q_f \quad (\text{K2-16})$$

$$\phi = 0.75 \text{ (LRFD)} \quad \Omega = 2.00 \text{ (ASD)}$$

(iii) For the limit state of sidewall local crippling in cross-connections,

$$P_n \sin \theta = [48t^3/(H - 3t)](EF_y)^{0.5} Q_f \quad (\text{K2-17})$$

$$\phi = 0.90 \text{ (LRFD)} \quad \Omega = 1.67 \text{ (ASD)}$$

(d) For the limit state of local yielding due to uneven load distribution,

$$P_n = F_{yb} t_b [2H_b + 2b_{eoi} - 4t_b] \quad (\text{K2-18})$$

$$\phi = 0.95 \text{ (LRFD)} \quad \Omega = 1.58 \text{ (ASD)}$$

where

$$b_{eoi} = [10/(B/t)][F_y t / (F_{yb} t_b)] B_b \leq B_b \quad (\text{K2-19})$$

This limit state need not be checked when $\beta < 0.85$.

3c. Branches with Axial Loads in Gapped K-Connections

For gapped K-connections, the design strength of the branch, ϕP_n , or the allowable strength of the branch, P_n/Ω , shall be the lowest value obtained according to the limit states of chord wall plastification, shear yielding (punching), *shear yielding* and local yielding due to uneven load distribution. In addition to the limits of applicability in Section K2.3a, the following limits shall apply:

- (1) $B_b/B \geq 0.1 + \gamma/50$
- (2) $\beta_{eff} \geq 0.35$
- (3) $\zeta \geq 0.5(1 - \beta_{eff})$
- (4) Gap: g greater than or equal to the sum of the branch wall thicknesses
- (5) The smaller $B_b > 0.63$ times the larger B_b

(a) For the limit state of chord wall plastification,

$$P_n \sin \theta = F_y t^2 [9.8 \beta_{eff} \gamma^{0.5}] Q_f \quad (\text{K2-20})$$

$$\phi = 0.90 \text{ (LRFD)} \quad \Omega = 1.67 \text{ (ASD)}$$

(b) For the limit state of shear yielding (punching),

$$P_n \sin \theta = 0.6 F_y t B [2\eta + \beta + \beta_{eop}] \quad (\text{K2-21})$$

$$\phi = 0.95 \text{ (LRFD)} \quad \Omega = 1.58 \text{ (ASD)}$$

In the above equation, the effective outside punching parameter $\beta_{eop} = 5 \beta/\gamma$ shall not exceed β .

This limit state need only be checked if $B_b < (B - 2t)$ or the branch is not square.

(c) For the limit state of shear yielding of the chord in the gap, available strength shall be checked in accordance with Section G5. This limit state need only be checked if the chord is not square.

(d) For the limit state of local yielding due to uneven load distribution,

$$P_n = F_{yb}t_b[2H_b + B_b + b_{eoi} - 4t_b] \quad (K2-22)$$

$$\phi = 0.95 \text{ (LRFD)} \quad \Omega = 1.58 \text{ (ASD)}$$

where

$$b_{eoi} = [10/(B/t)][F_y t / (F_{yb} t_b)] B_b \leq B_b \quad (K2-23)$$

This limit state need only be checked if the branch is not square or $B/t < 15$.

3d. Branches with Axial Loads in Overlapped K-Connections

For overlapped K-connections, the design strength of the branch, ϕP_n , or the allowable strength of the branch, P_n/Ω , shall be determined from the limit state of local yielding due to uneven load distribution,

$$\phi = 0.95 \text{ (LRFD)} \quad \Omega = 1.58 \text{ (ASD)}$$

For the overlapping branch, and for overlap $25\% \leq O_v \leq 50\%$ measured with respect to the overlapping branch,

$$P_n = F_{ybi} t_{bi} [(O_v/50)(2H_{bi} - 4t_{bi}) + b_{eoi} + b_{eov}] \quad (K2-24)$$

For the overlapping branch, and for overlap $50\% \leq O_v < 80\%$ measured with respect to the overlapping branch,

$$P_n = F_{ybi} t_{bi} [2H_{bi} - 4t_{bi} + b_{eoi} + b_{eov}] \quad (K2-25)$$

For the overlapping branch, and for overlap $80\% \leq O_v \leq 100\%$ measured with respect to the overlapping branch,

$$P_n = F_{ybi} t_{bi} [2H_{bi} - 4t_{bi} + B_{bi} + b_{eov}] \quad (K2-26)$$

where

b_{eoi} is the *effective width* of the *branch face* welded to the chord,

$$b_{eoi} = [10/(B/t)][(F_y t) / (F_{ybi} t_{bi})] B_{bi} \leq B_{bi} \quad (K2-27)$$

b_{eov} is the *effective width* of the *branch face* welded to the overlapped brace,

$$b_{eov} = [10/(B_{bj}/t_{bj})][(F_{ybj} t_{bj}) / (F_{ybi} t_{bi})] B_{bi} \leq B_{bi} \quad (K2-28)$$

B_{bi} = overall branch width of the overlapping branch, in. (mm)

B_{bj} = overall branch width of the overlapped branch, in. (mm)

F_{ybi} = *specified minimum yield stress* of the overlapping branch material, ksi (MPa)

F_{ybj} = *specified minimum yield stress* of the overlapped branch material, ksi (MPa)

H_{bi} = overall depth of the overlapping branch, in. (mm)

t_{bi} = thickness of the overlapping branch, in. (mm)

t_{bj} = thickness of the overlapped branch, in. (mm)

For the overlapped branch, P_n shall not exceed P_n of the overlapping branch, calculated using Equation K2-24, K2-25, or K2-26, as applicable, multiplied by the factor $(A_{bj}F_{ybj}/A_{bi}F_{ybi})$,

where

A_{bi} = cross-sectional area of the overlapping branch

A_{bj} = cross-sectional area of the overlapped branch

3e. Welds to Branches

The nonuniformity of load transfer along the line of weld, due to differences in relative flexibility of HSS walls in HSS-to-HSS connections, shall be considered in proportioning such welds. This can be considered by limiting the total effective weld length, L_e , of groove and *fillet welds* to rectangular HSS as follows:

(a) In T-, Y- and cross-connections,

for $\theta \leq 50$ degrees

$$L_e = \frac{2(H_b - 1.2t_b)}{\sin\theta} + (B_b - 1.2t_b) \quad (\text{K2-29})$$

for $\theta \geq 60$ degrees

$$L_e = \frac{2(H_b - 1.2t_b)}{\sin\theta} \quad (\text{K2-30})$$

Linear interpolation shall be used to determine L_e for values of θ between 50 and 60 degrees.

(b) In gapped K-connections, around each branch,

for $\theta \leq 50$ degrees

$$L_e = \frac{2(H_b - 1.2t_b)}{\sin\theta} + 2(B_b - 1.2t_b) \quad (\text{K2-31})$$

for $\theta \geq 60$ degrees

$$L_e = \frac{2(H_b - 1.2t_b)}{\sin\theta} + (B_b - 1.2t_b) \quad (\text{K2-32})$$

Linear interpolation shall be used to determine L_e for values of θ between 50 and 60 degrees.

In lieu of the above criteria in Equations K2-29 to K2-32, other rational criteria are permitted.

K3. HSS-TO-HSS MOMENT CONNECTIONS

HSS-to-HSS moment connections are defined as *connections* that consist of one or two *branch members* that are directly welded to a continuous chord that passes through the connection, with the branch or branches loaded by bending moments. A connection shall be classified

(a) As a *T-connection* when there is one branch and it is perpendicular to the chord and as a *Y-connection* when there is one branch but not perpendicular to the chord.

- (b) As a *cross-connection* when there is a branch on each (opposite) side of the chord.

For the purposes of this Specification, the centerlines of the branch member(s) and the *chord member* shall lie in a common plane.

1. Definitions of Parameters

B = overall width of rectangular HSS main member, measured 90 degrees to the plane of the connection, in. (mm)

B_b = overall width of rectangular HSS branch member, measured 90 degrees to the plane of the connection, in. (mm)

D = outside diameter of round HSS main member, in. (mm)

D_b = outside diameter of round HSS branch member, in. (mm)

F_y = *specified minimum yield stress* of HSS main member, ksi (MPa)

F_{yb} = *specified minimum yield stress* of HSS branch member, ksi (MPa)

F_u = *ultimate strength* of HSS member, ksi (MPa)

H = overall height of rectangular HSS main member, measured in the plane of the connection, in. (mm)

H_b = overall height of rectangular HSS branch member, measured in the plane of the connection, in. (mm)

t = *design wall thickness* of HSS main member, in. (mm)

t_b = *design wall thickness* of HSS branch member, in. (mm)

β = the width ratio; the ratio of branch diameter to chord diameter = D_b/D for round HSS; the ratio of overall branch width to chord width = B_b/B for rectangular HSS

γ = the chord slenderness ratio; the ratio of one-half the diameter to the wall thickness = $D/2t$ for round HSS; the ratio of one-half the width to wall thickness = $B/2t$ for rectangular HSS

η = the *load length parameter*, applicable only to rectangular HSS; the ratio of the length of contact of the branch with the chord in the plane of the connection to the chord width = N/B , where $N = H_b/\sin\theta$

θ = acute angle between the branch and chord (degrees)

2. Criteria for Round HSS

The interaction of *stress* due to *chord member forces* and local branch *connection forces* shall be incorporated through the chord-stress interaction parameter Q_f .

When the chord is in tension,

$$Q_f = 1$$

When the chord is in compression,

$$Q_f = 1.0 - 0.3U(1 + U) \quad (\text{K3-1})$$

where U is the utilization ratio given by

$$U = |P_r/A_gF_c + M_r/SF_c| \quad (\text{K3-2})$$

and

- P_r = required axial strength in chord, kips (N).
 M_r = required flexural strength in chord, kip-in. (N-mm)
 A_g = chord gross area, in.² (mm²)
 F_c = available stress, ksi (MPa)
 S = chord elastic section modulus, in.³ (mm³)

For design according to Section B3.3 (LRFD):

- $P_r = P_u$ = required axial strength in chord, using *LRFD load combinations*, kips (N)
 $M_r = M_u$ = required flexural strength in chord, using LRFD load combinations, kip-in. (N-mm)
 $F_c = F_y$, ksi (MPa)

For design according to Section B3.4 (ASD):

- $P_r = P_a$ = required axial strength in chord, using *ASD load combinations*, kips (N)
 $M_r = M_a$ = required flexural strength in chord, using ASD load combinations, kip-in. (N-mm)
 $F_c = 0.6F_y$, ksi (MPa)

2a. Limits of Applicability

The criteria herein are applicable only when the connection configuration is within the following limits of applicability:

- (1) Branch angle: $\theta \geq 30^\circ$
- (2) Chord wall slenderness: ratio of diameter to wall thickness less than or equal to 50 for *T-* and *Y-connections*; less than or equal to 40 for *cross-connections*
- (3) Tension branch wall slenderness: ratio of diameter to wall thickness less than or equal to 50
- (4) Compression branch wall slenderness: ratio of diameter to wall thickness less than or equal to $0.05E/F_y$
- (5) Width ratio: $0.2 < D_b/D \leq 1.0$
- (6) Strength: $F_y \leq 52$ ksi (360 MPa) for chord and branches
- (7) Ductility: $F_y/F_u \leq 0.8$

2b. Branches with In-Plane Bending Moments in T-, Y- and Cross-Connections

The *design strength*, ϕM_n , and the *allowable strength*, M_n/Ω , shall be the lowest value obtained according to the *limit states* of *chord plastification* and *shear yielding (punching)*.

(a) For the limit state of chord plastification,

$$M_n \sin \theta = 5.39 F_y t^2 \gamma^{0.5} \beta D_b Q_f \quad (\text{K3-3})$$

$$\phi = 0.90 \text{ (LRFD)} \quad \Omega = 1.67 \text{ (ASD)}$$

(b) For the limit state of shear yielding (punching),

$$M_n = 0.6F_y t D_b^2 [(1 + 3\sin\theta)/4\sin^2\theta] \quad (\text{K3-4})$$

$$\phi = 0.95 \text{ (LRFD)} \quad \Omega = 1.58 \text{ (ASD)}$$

This limit state need not be checked when $\beta > (1 - 1/\gamma)$.

2c. Branches with Out-of-Plane Bending Moments in T-, Y- and Cross-Connections

The design strength, ϕM_n , and the allowable strength, M_n/Ω , shall be the lowest value obtained according to the limit states of chord plastification and shear yielding (punching).

(a) For the limit state of chord plastification,

$$M_n \sin\theta = F_y t^2 D_b [3.0/(1 - 0.81\beta)] Q_f \quad (\text{K3-5})$$

$$\phi = 0.90 \text{ (LRFD)} \quad \Omega = 1.67 \text{ (ASD)}$$

(b) For the limit state of shear yielding (punching),

$$M_n = 0.6F_y t D_b^2 [(3 + \sin\theta)/4\sin^2\theta] Q_f \quad (\text{K3-6})$$

$$\phi = 0.95 \text{ (LRFD)} \quad \Omega = 1.58 \text{ (ASD)}$$

This limit state need not be checked when $\beta > (1 - 1/\gamma)$.

2d. Branches with Combined Bending Moment and Axial Force in T-, Y- and Cross-Connections

Connections subject to branch axial load, branch in-plane bending moment, and branch out-of-plane bending moment, or any combination of these *load effects*, should satisfy the following.

For design according to Section B3.3 (LRFD):

$$(P_r/\phi P_n) + (M_{r-ip}/\phi M_{n-ip})^2 + (M_{r-op}/\phi M_{n-op}) \leq 1.0 \quad (\text{K3-7})$$

where

P_r = P_u = required axial strength in branch, using LRFD load combinations, kips (N)

ϕP_n = design strength obtained from Section K2.2b

M_{r-ip} = required in-plane flexural strength in branch, using LRFD load combinations, kip-in. (N-mm)

ϕM_{n-ip} = design strength obtained from Section K3.2b

M_{r-op} = required out-of-plane flexural strength in branch, using LRFD load combinations, kip-in. (N-mm)

ϕM_{n-op} = design strength obtained from Section K3.2c

For design according to Section B3.4 (ASD):

$$(P_r/(P_n/\Omega)) + (M_{r-ip}/(M_{n-ip}/\Omega))^2 + (M_{r-op}/(M_{n-op}/\Omega)) \leq 1.0 \quad (\text{K3-8})$$

where

P_r = P_a = required axial strength in branch, using ASD load combinations, kips (N)

P_n/Ω = allowable strength obtained from Section K2.2b

M_{r-ip} = required in-plane flexural strength in branch, using ASD load combinations, kip-in. (N-mm)

M_{n-ip}/Ω = allowable strength obtained from Section K3.2b

M_{r-op} = required out-of-plane flexural strength in branch, using ASD load combinations, kip-in. (N-mm)

M_{n-op}/Ω = allowable strength obtained from Section K3.2c

3. Criteria for Rectangular HSS

The interaction of *stress* due to *chord member forces* and local branch *connection* forces shall be incorporated through the chord-stress interaction parameter Q_f .

When the chord is in tension,

$$Q_f = 1$$

When the chord is in compression,

$$Q_f = (1.3 - 0.4U/\beta) \leq 1 \quad (\text{K3-9})$$

where U is the utilization ratio given by

$$U = |P_r/A_g F_c + M_r/SF_c| \quad (\text{K3-10})$$

and

P_r = required axial strength in chord, kips (N)

M_r = required flexural strength in chord, kip-in. (N-mm)

A_g = chord gross area, in.² (mm²)

F_c = available stress, ksi, (MPa)

S = chord elastic section modulus, in.³ (mm³)

For design according to Section B3.3 (LRFD):

$P_r = P_u$ = required axial strength in chord, using LRFD load combinations, kips, (N)

$M_r = M_u$ = required flexural strength in chord, using LRFD load combinations, kip-in. (N-mm)

$F_c = F_y$, ksi, (MPa)

For design according to Section B3.4 (ASD):

$P_r = P_a$ = required axial strength in chord, using ASD load combinations, kips, (N)

$M_r = M_a$ = required flexural strength in chord, using ASD load combinations, kip-in. (N-mm)

$F_c = 0.6F_y$, ksi, (MPa)

3a. Limits of Applicability

The criteria herein are applicable only when the *connection* configuration is within the following limits:

- (1) Branch angle is approximately 90°
- (2) Chord wall slenderness: ratio of overall wall width to thickness less than or equal to 35
- (3) Tension branch wall slenderness: ratio of overall wall width to thickness less than or equal to 35
- (4) Compression branch wall slenderness: ratio of overall wall width to thickness less than or equal to $1.25(E/F_{yb})^{0.5}$ and also less than 35
- (5) Width ratio: ratio of overall wall width of branch to overall wall width of chord greater than or equal to 0.25
- (6) Aspect ratio: $0.5 \leq \text{ratio of depth to width} \leq 2.0$
- (7) Strength: $F_y \leq 52 \text{ ksi (360 MPa)}$ for chord and branches
- (8) Ductility: $F_y/F_u \leq 0.8$
- (9) Other limits apply for specific criteria

3b. Branches with In-Plane Bending Moments in T- and Cross-Connections

The *design strength*, ϕM_n , and the *allowable strength*, M_n/Ω , shall be the lowest value obtained according to the *limit states* of *chord wall plastification*, *sidewall local yielding* and local yielding due to *uneven load distribution*.

- (a) For the limit state of chord wall plastification,

$$M_n = F_y t^2 H_b [(1/2\eta) + 2/(1 - \beta)^{0.5} + \eta/(1 - \beta)] Q_f \quad (\text{K3-11})$$

$$\phi = 1.00 \text{ (LRFD)} \quad \Omega = 1.50 \text{ (ASD)}$$

This limit state need not be checked when $\beta > 0.85$.

- (b) For the limit state of sidewall local yielding,

$$M_n = 0.5 F_y^* t (H_b + 5t)^2 \quad (\text{K3-12})$$

$$\phi = 1.00 \text{ (LRFD)} \quad \Omega = 1.50 \text{ (ASD)}$$

where

$$F_y^* = F_y \text{ for } T\text{-connections}$$

$$F_y^* = 0.8 F_y \text{ for cross-connections}$$

This limit state need not be checked when $\beta < 0.85$.

- (c) For the limit state of local yielding due to uneven load distribution,

$$M_n = F_{yb} [Z_b - (1 - b_{eoi}/B_b) B_b H_b t_b] \quad (\text{K3-13})$$

$$\phi = 0.95 \text{ (LRFD)} \quad \Omega = 1.58 \text{ (ASD)}$$

where

$$b_{eoi} = [10/(B/t)][F_y t / (F_{yb} t_b)] B_b \leq B_b \quad (\text{K3-14})$$

Z_b = branch plastic section modulus about the axis of bending, in.³(mm³)

This limit state need not be checked when $\beta < 0.85$.

3c. Branches with Out-of-Plane Bending Moments in T- and Cross-Connections

The design strength, ϕM_n , and the allowable strength, M_n / Ω , shall be the lowest value obtained according to the limit states of chord wall plastification, sidewall local yielding, local yielding due to uneven load distribution and chord *distortional failure*.

(a) For the limit state of chord wall plastification,

$$M_n = F_y t^2 [0.5 H_b (1 + \beta) / (1 - \beta) + [2 B B_b (1 + \beta) / (1 - \beta)]^{0.5}] Q_f \quad (\text{K3-15})$$

$$\phi = 1.00 \text{ (LRFD)} \quad \Omega = 1.50 \text{ (ASD)}$$

This limit state need not be checked when $\beta > 0.85$.

(b) For the limit state of sidewall local yielding,

$$M_n = F_y^* t (B - t) (H_b + 5t) \quad (\text{K3-16})$$

$$\phi = 1.00 \text{ (LRFD)} \quad \Omega = 1.50 \text{ (ASD)}$$

where

$$F_y^* = F_y \text{ for T-connections}$$

$$F_y^* = 0.8 F_y \text{ for cross-connections}$$

This limit state need not be checked when $\beta < 0.85$.

(c) For the limit state of local yielding due to uneven load distribution,

$$M_n = F_{yb} [Z_b - 0.5(1 - b_{eoi}/B_b)^2 B_b^2 t_b] \quad (\text{K3-17})$$

$$\phi = 0.95 \text{ (LRFD)} \quad \Omega = 1.58 \text{ (ASD)}$$

where

$$b_{eoi} = [10/(B/t)][F_y t / (F_{yb} t_b)] B_b \leq B_b \quad (\text{K3-18})$$

Z_b = branch plastic section modulus about the axis of bending, in.³(mm³)

This limit state need not be checked when $\beta < 0.85$.

(d) For the limit state of chord distortional failure,

$$M_n = 2 F_y t [H_b t + [B H t (B + H)]^{0.5}] \quad (\text{K3-19})$$

$$\phi = 1.00 \text{ (LRFD)} \quad \Omega = 1.50 \text{ (ASD)}$$

This limit state need not be checked for cross-connections or for T-connections if chord distortional failure is prevented by other means.

3d. Branches with Combined Bending Moment and Axial Force in T- and Cross-Connections

Connections subject to branch axial *load*, branch in-plane bending moment, and branch out-of-plane bending moment, or any combination of these *load effects*, should satisfy

For design according to Section B3.3 (LRFD)

$$(P_r/\phi P_n) + (M_{r-ip}/\phi M_{n-ip}) + (M_{r-op}/\phi M_{n-op}) \leq 1.0 \quad (\text{K3-20})$$

where

P_r = P_u = required axial strength in branch, using LRFD load combinations, kips (N)

ϕP_n = design strength obtained from Section K2.3b

M_{r-ip} = required in-plane flexural strength in branch, using LRFD load combinations, kip-in. (N-mm)

ϕM_{n-ip} = design strength obtained from Section K3.3b

M_{r-op} = required out-of-plane flexural strength in branch, using LRFD load combinations, kip-in. (N-mm)

ϕM_{n-op} = design strength obtained from Section K3.3c

For design according to Section B3.4 (ASD)

$$(P_r/(P_n/\Omega)) + (M_{r-ip}/(M_{n-ip}/\Omega)) + (M_{r-op}/(M_{n-op}/\Omega)) \leq 1.0 \quad (\text{K3-21})$$

where

P_r = P_a = required axial strength in branch, using ASD load combinations, kips (N)

P_n/Ω = allowable strength obtained from Section K2.3b

M_{r-ip} = required in-plane flexural strength in branch, using ASD load combinations, kip-in. (N-mm)

M_{n-ip}/Ω = allowable strength obtained from Section K3.3b

M_{r-op} = required out-of-plane flexural strength in branch, using ASD load combinations, kip-in. (N-mm)

M_{n-op}/Ω = allowable strength obtained from Section K3.3c

CHAPTER L

DESIGN FOR SERVICEABILITY

This chapter addresses *serviceability* performance design requirements.

The chapter is organized as follows:

- L1. General Provisions
- L2. Camber
- L3. Deflections
- L4. Drift
- L5. Vibration
- L6. Wind-Induced Motion
- L7. Expansion and Contraction
- L8. Connection Slip

L1. GENERAL PROVISIONS

Serviceability is a state in which the function of a building, its appearance, maintainability, durability, and comfort of its occupants are preserved under normal usage. Limiting values of structural behavior for serviceability (for example, maximum deflections, accelerations) shall be chosen with due regard to the intended function of the structure. Serviceability shall be evaluated using appropriate *load combinations* for the serviceability *limit states* identified.

User Note: Additional information on serviceability limit states, service loads and appropriate load combinations for serviceability requirements can be found in ASCE 7, Appendix B and its Commentary. The performance requirements for serviceability in this chapter are consistent with those requirements. Service loads, as stipulated herein, are those that act on the structure at an arbitrary point in time. That is, the appropriate load combinations are often less severe than those in ASCE 7, Section 2.4, where the LRFD load combinations are given.

L2. CAMBER

Where *camber* is used to achieve proper position and location of the structure, the magnitude, direction and location of camber shall be specified in the structural drawings.

User Note: Camber recommendations are provided in the *Code of Standard Practice for Steel Buildings and Bridges*.

L3. DEFLECTIONS

Deflections in structural members and structural systems under appropriate *service load combinations* shall not impair the *serviceability* of the structure.

User Note: Conditions to be considered include levelness of floors, alignment of structural members, integrity of building finishes, and other factors that affect the normal usage and function of the structure. For *composite* members, the additional deflections due to the shrinkage and creep of the concrete should be considered.

L4. DRIFT

Drift of a structure shall be evaluated under *service loads* to provide for *serviceability* of the structure, including the integrity of interior partitions and exterior *cladding*. *Drift* under *strength load combinations* shall not cause collision with adjacent structures or exceed the limiting values of such drifts that may be specified by the *applicable building code*.

L5. VIBRATION

The effect of vibration on the comfort of the occupants and the function of the structure shall be considered. The sources of vibration to be considered include pedestrian loading, vibrating machinery and others identified for the structure.

L6. WIND-INDUCED MOTION

The effect of wind-induced motion of buildings on the comfort of occupants shall be considered.

L7. EXPANSION AND CONTRACTION

The effects of thermal expansion and contraction of a building shall be considered. Damage to building *cladding* can cause water penetration and may lead to corrosion.

L8. CONNECTION SLIP

The effects of *connection slip* shall be included in the design where slip at bolted connections may cause deformations that impair the *serviceability* of the structure. Where appropriate, the connection shall be designed to preclude slip. For the design of slip-critical connections see Sections J3.8 and J3.9.

User Note: For more information on connection slip, refer to the RCSC *Specification for Structural Joints Using ASTM A325 or A490 Bolts*.

CHAPTER M

FABRICATION, ERECTION AND QUALITY CONTROL

This chapter addresses requirements for shop drawings, fabrication, shop painting, erection and *quality control*.

The chapter is organized as follows:

- M1. Shop and Erection Drawings
- M2. Fabrication
- M3. Shop Painting
- M4. Erection
- M5. Quality Control

M1. SHOP AND ERECTION DRAWINGS

Shop drawings shall be prepared in advance of fabrication and give complete information necessary for the fabrication of the component parts of the structure, including the location, type and size of welds and bolts. Erection drawings shall be prepared in advance of erection and give information necessary for erection of the structure. Shop and erection drawings shall clearly distinguish between shop and field welds and bolts and shall clearly identify pretensioned and slip-critical high-strength bolted *connections*. Shop and erection drawings shall be made with due regard to speed and economy in fabrication and erection.

M2. FABRICATION

1. Cambering, Curving and Straightening

Local application of heat or mechanical means is permitted to be used to introduce or correct *camber*, curvature and straightness. The temperature of heated areas, as measured by approved methods, shall not exceed 1,100 °F (593 °C) for A514/A514M and A852/A852M steel nor 1,200 °F (649 °C) for other steels.

2. Thermal Cutting

Thermally cut edges shall meet the requirements of AWS D1.1, Sections 5.15.1.2, 5.15.4.3 and 5.15.4.4 with the exception that thermally cut free edges that will be subject to calculated static tensile *stress* shall be free of round-bottom *gouges* greater than $\frac{3}{16}$ in. (5 mm) deep and sharp V-shaped notches. *Gouges* deeper than $\frac{3}{16}$ in. (5 mm) and notches shall be removed by grinding or repaired by welding.

Reentrant corners, except reentrant corners of *beam copes* and weld access holes, shall meet the requirements of AWS D1.1, Section A5.16. If another specified contour is required it must be shown on the contract documents.

Beam copes and weld access holes shall meet the geometrical requirements of Section J1.6. Beam copes and weld access holes in shapes that are to be galvanized shall be ground. For shapes with a flange thickness not exceeding 2 in. (50 mm) the roughness of *thermally cut* surfaces of copes shall be no greater than a surface roughness value of 2,000 $\mu\text{in.}$ (50 μm) as defined in ASME B46.1 Surface Texture (*Surface Roughness, Waviness, and Lay*). For beam copes and weld access holes in which the curved part of the access hole is thermally cut in ASTM A6/A6M hot-rolled shapes with a flange thickness exceeding 2 in. (50 mm) and welded built-up shapes with material thickness greater than 2 in. (50 mm), a preheat temperature of not less than 150 °F (66 °C) shall be applied prior to thermal cutting. The thermally cut surface of access holes in ASTM A6/A6M hot-rolled shapes with a flange thickness exceeding 2 in. (50 mm) and built-up shapes with a material thickness greater than 2 in. (50 mm) shall be ground and inspected for cracks using magnetic particle inspection in accordance with ASTM E709. Any crack is unacceptable regardless of size or location.

User Note: The AWS Surface Roughness Guide for Oxygen Cutting (AWS C4.1-77) sample 3 may be used as a guide for evaluating the surface roughness of *copers* in shapes with flanges not exceeding 2 in. (50 mm) thick.

3. Planing of Edges

Planing or finishing of sheared or *thermally cut* edges of plates or shapes is not required unless specifically called for in the contract documents or included in a stipulated edge preparation for welding.

4. Welded Construction

The technique of welding, the workmanship, appearance and quality of welds, and the methods used in correcting nonconforming work shall be in accordance with AWS D1.1 except as modified in Section J2.

5. Bolted Construction

Parts of bolted members shall be pinned or bolted and rigidly held together during assembly. Use of a *drift* pin in bolt holes during assembly shall not distort the metal or enlarge the holes. Poor matching of holes shall be cause for rejection.

Bolt holes shall comply with the provisions of the RCSC *Specification for Structural Joints Using ASTM A325 or A490 Bolts*, Section 3.3 except that *thermally cut* holes shall be permitted with a surface roughness profile not exceeding 1,000 $\mu\text{in.}$ (25 μm) as defined in ASME B46.1. *Gouges* shall not exceed a depth of $1/16$ in. (2 mm).

Fully inserted finger *shims*, with a total thickness of not more than $\frac{1}{4}$ in. (6 mm) within a *joint*, are permitted in *joints* without changing the strength (based upon hole type) for the design of *connections*. The orientation of such *shims* is independent of the direction of application of the *load*.

The use of high-strength bolts shall conform to the requirements of the RCSC *Specification for Structural Joints Using ASTM A325 or A490 Bolts*, except as modified in Section J3.

6. Compression Joints

Compression *joints* that depend on contact bearing as part of the *splice* strength shall have the bearing surfaces of individual fabricated pieces prepared by milling, sawing, or other suitable means.

7. Dimensional Tolerances

Dimensional tolerances shall be in accordance with the AISC *Code of Standard Practice for Steel Buildings and Bridges*.

8. Finish of Column Bases

Column bases and base plates shall be finished in accordance with the following requirements:

- (1) Steel bearing plates 2 in. (50 mm) or less in thickness are permitted without milling, provided a satisfactory contact bearing is obtained. Steel bearing plates over 2 in. (50 mm) but not over 4 in. (100 mm) in thickness are permitted to be straightened by pressing or, if presses are not available, by milling for bearing surfaces (except as noted in subparagraphs 2 and 3 of this section), to obtain a satisfactory contact bearing. Steel bearing plates over 4 in. (100 mm) in thickness shall be milled for bearing surfaces (except as noted in subparagraphs 2 and 3 of this section).
- (2) Bottom surfaces of bearing plates and *column* bases that are grouted to ensure full bearing contact on foundations need not be milled.
- (3) Top surfaces of bearing plates need not be milled when complete-*joint*-penetration *groove welds* are provided between the *column* and the bearing plate.

9. Holes for Anchor Rods

Holes for anchor rods shall be permitted to be *thermally cut* in accordance with the provisions of Section M2.2.

10. Drain Holes

When water can collect inside *HSS* or box members, either during construction or during service, the member shall be sealed, provided with a drain hole at the base, or protected by other suitable means.

11. Requirements for Galvanized Members

Members and parts to be galvanized shall be designed, detailed and fabricated to provide for flow and drainage of pickling fluids and zinc and to prevent pressure build-up in enclosed parts.

User Note: See *The Design of Products to be Hot-Dip Galvanized After Fabrication*, American Galvanizer's Association, and ASTM A123, A153, A384 and A780 for useful information on design and detailing of galvanized members.

M3. SHOP PAINTING

1. General Requirements

Shop painting and surface preparation shall be in accordance with the provisions of the AISC *Code of Standard Practice for Steel Buildings and Bridges*.

Shop paint is not required unless specified by the contract documents.

2. Inaccessible Surfaces

Except for contact surfaces, surfaces inaccessible after shop assembly shall be cleaned and painted prior to assembly, if required by the design documents.

3. Contact Surfaces

Paint is permitted in *bearing-type connections*. For *slip-critical connections*, the *faying surface* requirements shall be in accordance with the RCSC *Specification for Structural Joints Using ASTM A325 or A490 Bolts*, Section 3.2.2(b).

4. Finished Surfaces

Machine-finished surfaces shall be protected against corrosion by a rust inhibitive coating that can be removed prior to erection, or which has characteristics that make removal prior to erection unnecessary.

5. Surfaces Adjacent to Field Welds

Unless otherwise specified in the design documents, surfaces within 2 in. (50 mm) of any field weld location shall be free of materials that would prevent proper welding or produce objectionable fumes during welding.

M4. ERECTION

1. Alignment of Column Bases

Column bases shall be set level and to correct elevation with full bearing on concrete or masonry.

2. Bracing

The frame of steel skeleton buildings shall be carried up true and plumb within the limits defined in the AISC *Code of Standard Practice for Steel Buildings and*

Bridges. Temporary bracing shall be provided, in accordance with the requirements of the *Code of Standard Practice for Steel Buildings and Bridges*, wherever necessary to support the loads to which the structure may be subjected, including equipment and the operation of same. Such bracing shall be left in place as long as required for safety.

3. Alignment

No permanent bolting or welding shall be performed until the adjacent affected portions of the structure have been properly aligned.

4. Fit of Column Compression Joints and Base Plates

Lack of contact bearing not exceeding a gap of $1/16$ in. (2 mm), regardless of the type of *splice* used (*partial-joint-penetration groove welded* or bolted), is permitted. If the gap exceeds $1/16$ in. (2 mm), but is less than $1/4$ in. (6 mm), and if an engineering investigation shows that sufficient contact area does not exist, the gap shall be packed out with nontapered steel *shims*. Shims need not be other than mild steel, regardless of the grade of the main material.

5. Field Welding

Shop paint on surfaces adjacent to *joints* to be field welded shall be wire brushed if necessary to assure weld quality.

Field welding of attachments to installed embedments in contact with concrete shall be done in such a manner as to avoid excessive thermal expansion of the embedment which could result in spalling or cracking of the concrete or excessive *stress* in the embedment anchors.

6. Field Painting

Responsibility for touch-up painting, cleaning and field painting shall be allocated in accordance with accepted local practices, and this allocation shall be set forth explicitly in the design documents.

7. Field Connections

As erection progresses, the structure shall be securely bolted or welded to support the dead, wind and erection *loads*.

M5. QUALITY CONTROL

The fabricator shall provide *quality control* procedures to the extent that the fabricator deems necessary to assure that the work is performed in accordance with this Specification. In addition to the fabricator's quality control procedures, material and workmanship at all times may be subject to inspection by qualified inspectors representing the purchaser. If such inspection by representatives of the purchaser will be required, it shall be so stated in the design documents.

1. Cooperation

As far as possible, the inspection by representatives of the purchaser shall be made at the fabricator's plant. The fabricator shall cooperate with the inspector, permitting access for inspection to all places where work is being done. The purchaser's inspector shall schedule this work for minimum interruption to the work of the fabricator.

2. Rejections

Material or workmanship not in conformance with the provisions of this Specification may be rejected at any time during the progress of the work.

The fabricator shall receive copies of all reports furnished to the purchaser by the inspection agency.

3. Inspection of Welding

The inspection of welding shall be performed in accordance with the provisions of AWS D1.1 except as modified in Section J2.

When visual inspection is required to be performed by AWS certified welding inspectors, it shall be so specified in the design documents.

When nondestructive testing is required, the process, extent and standards of acceptance shall be clearly defined in the design documents.

4. Inspection of Slip-Critical High-Strength Bolted Connections

The inspection of slip-critical high-strength bolted *connections* shall be in accordance with the provisions of the RCSC *Specification for Structural Joints Using ASTM A325 or A490 Bolts*.

5. Identification of Steel

The fabricator shall be able to demonstrate by a written procedure and by actual practice a method of material identification, visible at least through the "fit-up" operation, for the main structural elements of each shipping piece.

APPENDIX 1

INELASTIC ANALYSIS AND DESIGN

Design by *inelastic analysis* is subject to the supplementary provisions of this appendix.

The appendix is organized as follows:

- 1.1. General Provisions
- 1.2. Materials
- 1.3. Moment Redistribution
- 1.4. Local Buckling
- 1.5. Stability and Second-Order Effects
- 1.6. Columns and Other Compression Members
- 1.7. Beams and Other Flexural Members
- 1.8. Members under Combined Forces
- 1.9. Connections

1.1. GENERAL PROVISIONS

Inelastic analysis is permitted for design according to the provisions of Section B3.3 (LRFD). Inelastic analysis is not permitted for design according to the provisions of Section B3.4 (ASD) except as provided in Section 1.3.

1.2. MATERIALS

Members undergoing plastic hinging shall have a *specified minimum yield stress* not exceeding 65 ksi (450 MPa).

1.3. MOMENT REDISTRIBUTION

Beams and girders composed of *compact sections* as defined in Section B4 and satisfying the *unbraced length* requirements of Section 1.7, including *composite members*, may be proportioned for nine-tenths of the negative moments at points of support, produced by the *gravity loading* computed by an *elastic analysis*, provided that the maximum positive moment is increased by one-tenth of the average negative moments. This reduction is not permitted for moments produced by loading on cantilevers and for design according to Sections 1.4 through 1.8 of this appendix.

If the negative moment is resisted by a *column* rigidly framed to the beam or girder, the one-tenth reduction may be used in proportioning the column for combined axial *force* and flexure, provided that the axial force does not exceed $0.15\phi_c F_y A_g$ for LRFD or $0.15 F_y A_g / \Omega_c$ for ASD,

where

A_g = gross area of member, in.² (mm²)

F_y = *specified minimum yield stress* of the compression flange, ksi (MPa)

$\phi_c = \text{resistance factor for compression} = 0.90$

$\Omega_c = \text{safety factor for compression} = 1.67$

1.4. LOCAL BUCKLING

Flanges and webs of members subject to plastic hinging in combined flexure and axial compression shall be compact with width-thickness ratios less than or equal to the limiting λ_p defined in Table B4.1 or as modified as follows:

(a) For webs of doubly symmetric wide flange members and rectangular *HSS* in combined flexure and compression

(i) For $P_u/\phi_b P_y \leq 0.125$

$$h/t_w \leq 3.76 \sqrt{\frac{E}{F_y}} \left(1 - \frac{2.75 P_u}{\phi_b P_y} \right) \quad (\text{A-1-1})$$

(ii) For $P_u/\phi_b P_y > 0.125$

$$h/t_w \leq 1.12 \sqrt{\frac{E}{F_y}} \left(2.33 - \frac{P_u}{\phi_b P_y} \right) \geq 1.49 \sqrt{\frac{E}{F_y}} \quad (\text{A-1-2})$$

where

$E = \text{modulus of elasticity of steel} = 29,000 \text{ ksi} (200\,000 \text{ MPa})$

$F_y = \text{specified minimum yield stress of the type of steel being used, ksi (MPa)}$

$h = \text{as defined in Section B4.2, in. (mm)}$

$P_u = \text{required axial strength in compression, kips (N)}$

$P_y = \text{member yield strength, kips (N)}$

$t_w = \text{web thickness, in. (mm)}$

$\phi_b = \text{resistance factor for flexure} = 0.90$

(b) For flanges of rectangular box and hollow structural sections of uniform thickness subject to bending or compression, flange *cover plates*, and *diaphragm plates* between lines of *fasteners* or welds

$$b/t \leq 0.94 \sqrt{E/F_y} \quad (\text{A-1-3})$$

where

$b = \text{as defined in Section B4.2, in. (mm)}$

$t = \text{as defined in Section B4.2, in. (mm)}$

(c) For circular hollow sections in flexure

$$D/t \leq 0.045 E/F_y \quad (\text{A-1-4})$$

where

$D = \text{outside diameter of round HSS member, in. (mm)}$

1.5. STABILITY AND SECOND-ORDER EFFECTS

Continuous *beams* not subjected to axial *loads* and that do not contribute to lateral *stability* of framed structures may be designed based on a *first-order inelastic analysis* or a *plastic mechanism analysis*.

Braced frames and *moment frames* may be designed based on a *first-order inelastic analysis* or a *plastic mechanism analysis* provided that *stability* and *second-order effects* are taken into account.

Structures may be designed on the basis of a second-order *inelastic analysis*. For *beam-columns*, *connections* and connected members, the *required strengths* shall be determined from a second-order inelastic analysis, where equilibrium is satisfied on the deformed geometry, taking into account the change in *stiffness* due to yielding.

1. Braced Frames

In *braced frames* designed on the basis of *inelastic analysis*, braces shall be designed to remain elastic under the *design loads*. The required axial strength for *columns* and compression braces shall not exceed $\phi_c (0.85 F_y A_g)$,

where

$$\phi_c = 0.90 \text{ (LRFD)}$$

2. Moment Frames

In *moment frames* designed on the basis of *inelastic analysis*, the required axial strength of columns shall not exceed $\phi_c (0.75 F_y A_g)$,

where

$$\phi_c = 0.90 \text{ (LRFD)}$$

1.6. COLUMNS AND OTHER COMPRESSION MEMBERS

In addition to the limits set in Sections 1.5.1 and 1.5.2, the required axial strength of *columns* designed on the basis of *inelastic analysis* shall not exceed the design strength, $\phi_c P_n$, determined according to the provisions of Section E3.

Design by inelastic analysis is permitted if the column slenderness ratio, L/r , does not exceed $4.71 \sqrt{E/F_y}$,

where

L = laterally unbraced length of a member, in. (mm)

r = governing radius of gyration, in. (mm)

User Note: A well-proportioned member will not be expected to reach this limit.

1.7. BEAMS AND OTHER FLEXURAL MEMBERS

The required moment strength, M_u , of beams designed on the basis of *inelastic analysis* shall not exceed the *design strength*, ϕM_n , where

$$M_n = M_p = F_y Z < 1.6 F_y S \quad (\text{A-1-6})$$

$$\phi = 0.90 \text{ (LRFD)}$$

Design by inelastic analysis is permitted for members that are compact as defined in Section B4 and as modified in Section 1.4.

The laterally *unbraced length*, L_b , of the compression flange adjacent to *plastic hinge* locations shall not exceed L_{pd} , determined as follows.

- (a) For doubly symmetric and singly symmetric I-shaped members with the compression flange equal to or larger than the tension flange loaded in the plane of the web:

$$L_{pd} = \left[0.12 + 0.076 \left(\frac{M_1}{M_2} \right) \right] \left(\frac{E}{F_y} \right) r_y \quad (\text{A-1-7})$$

where

M_1 = smaller moment at end of unbraced length of beam, kip-in. (N-mm)

M_2 = larger moment at end of unbraced length of beam, kip-in. (N-mm)

r_y = radius of gyration about minor axis, in. (mm)

(M_1/M_2) is positive when moments cause *reverse curvature* and negative for *single curvature*.

- (b) For solid rectangular bars and symmetric box beams:

$$L_{pd} = \left[0.17 + 0.10 \left(\frac{M_1}{M_2} \right) \right] \left(\frac{E}{F_y} \right) r_y \geq 0.10 \left(\frac{E}{F_y} \right) r_y \quad (\text{A-1-8})$$

There is no limit on L_b for members with circular or square cross sections or for any beam bent about its minor axis.

1.8. MEMBERS UNDER COMBINED FORCES

When inelastic analysis is used for symmetric members subject to bending and axial force, the provisions in Section H1 apply.

Inelastic analysis is not permitted for members subject to torsion and combined torsion, flexure, shear and/or axial force.

1.9. CONNECTIONS

Connections adjacent to plastic hinging regions of connected members shall be designed with sufficient strength and ductility to sustain the *forces* and deformations imposed under the required *loads*.

APPENDIX 2

DESIGN FOR PONDING

This appendix provides methods for determining whether a roof system has adequate strength and stiffness to resist ponding.

The appendix is organized as follows:

- 2.1. Simplified Design for Ponding
- 2.2. Improved Design for Ponding

2.1. SIMPLIFIED DESIGN FOR PONDING

The roof system shall be considered stable for *ponding* and no further investigation is needed if both of the following two conditions are met:

$$C_p + 0.9C_s \leq 0.25 \quad (\text{A-2-1})$$

$$I_d \geq 25(S^4)10^{-6} \quad (\text{A-2-2})$$

$$I_d \geq 3940 S^4 \text{ (S.I.)} \quad (\text{A-2-2M})$$

where

$$C_p = \frac{32L_s L_p^4}{10^7 I_p}$$

$$C_p = \frac{504L_s L_p^4}{I_p} \text{ (S.I.)}$$

$$C_s = \frac{32S L_s^4}{10^7 I_s}$$

$$C_s = \frac{504S L_s^4}{I_s} \text{ (S.I.)}$$

L_p = column spacing in direction of girder (length of primary members), ft (m)

L_s = column spacing perpendicular to direction of girder (length of secondary members), ft (m)

S = spacing of secondary members, ft (m)

I_p = moment of inertia of primary members, in.⁴ (mm⁴)

I_s = moment of inertia of secondary members, in.⁴ (mm⁴)

I_d = moment of inertia of the steel deck supported on secondary members, in.⁴ per ft (mm⁴ per m)

For trusses and steel joists, the moment of inertia I_s shall be decreased 15 percent when used in the above equation. A steel deck shall be considered a secondary member when it is directly supported by the primary members.

2.2. IMPROVED DESIGN FOR PONDING

The provisions given below are permitted to be used when a more exact determination of framing *stiffness* is needed than that given in Section 2.1.

For primary members, the stress index shall be

$$U_p = \left(\frac{0.8F_y - f_o}{f_o} \right)_p \quad (\text{A-2-3})$$

For secondary members, the stress index shall be

$$U_s = \left(\frac{0.8F_y - f_o}{f_o} \right)_s \quad (\text{A-2-4})$$

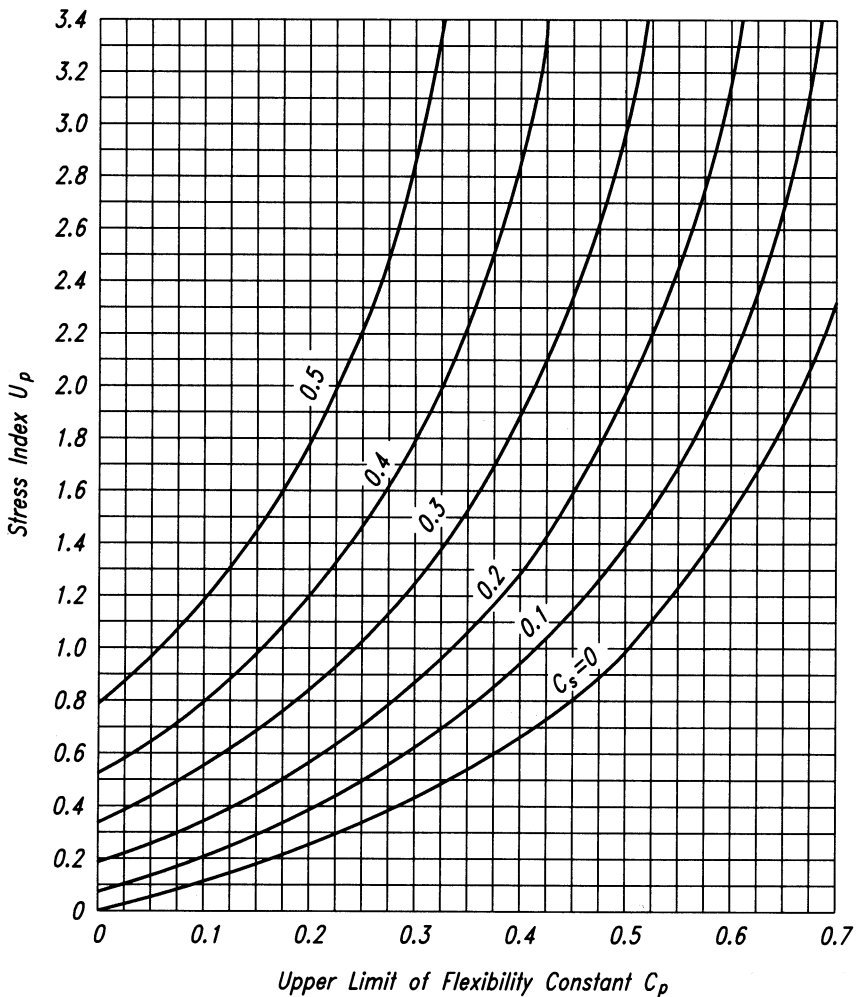

Fig. A-2-1. Limiting flexibility coefficient for the primary systems.

where

f_o = stress due to the load combination ($D + R$)

D = nominal dead load

R = nominal load due to rainwater or snow, exclusive of the *ponding* contribution, ksi (MPa)

For roof framing consisting of primary and secondary members, the combined stiffness shall be evaluated as follows: enter Figure A-2-1 at the level of the computed stress index U_p determined for the primary beam; move horizontally to the computed C_s value of the secondary beams and then downward to the abscissa scale. The combined stiffness of the primary and secondary framing is sufficient to prevent ponding if the flexibility constant read from this latter scale is more than the value of C_p computed for the given primary member; if not, a stiffer primary or secondary beam, or combination of both, is required.

A similar procedure must be followed using Figure A-2-2.

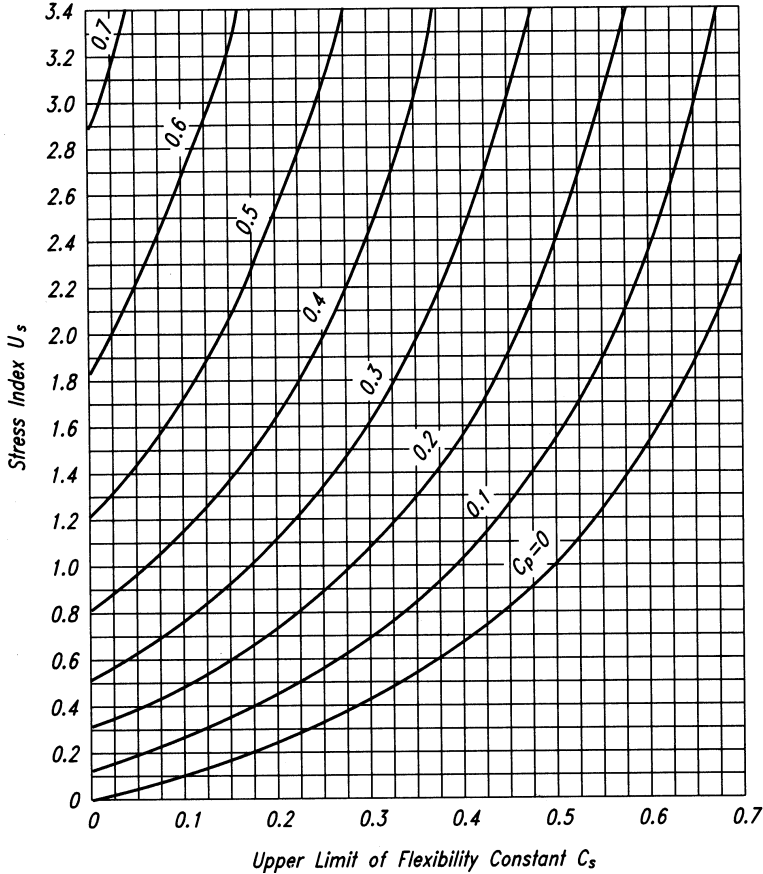

Fig. A-2-2. Limiting flexibility coefficient for the secondary systems.

For roof framing consisting of a series of equally spaced wall-bearing beams, the stiffness shall be evaluated as follows. The beams are considered as secondary members supported on an infinitely stiff primary member. For this case, enter Figure A-2-2 with the computed *stress* index U_s . The limiting value of C_s is determined by the intercept of a horizontal line representing the U_s value and the curve for $C_p = 0$.

User Note: The *ponding* deflection contributed by a metal deck is usually such a small part of the total ponding deflection of a roof panel that it is sufficient merely to limit its moment of inertia (per foot (meter) of width normal to its span) to $0.000025I^4$ in.⁴/ft ($3940I^4$ mm⁴/m).

For roof framing consisting of metal deck spanning between beams supported on columns, the stiffness shall be evaluated as follows. Employ Figure A-2-1 or A-2-2 using as C_s the flexibility constant for a 1 ft (1 m) width of the roof deck ($S = 1.0$).

APPENDIX 3

DESIGN FOR FATIGUE

This appendix applies to members and *connections* subject to high cycle loading within the elastic range of stresses of frequency and magnitude sufficient to initiate cracking and progressive failure, which defines the *limit state of fatigue*.

The appendix is organized as follows:

- 3.1. General
- 3.2. Calculation of Maximum Stresses and Stress Ranges
- 3.3. Design Stress Range
- 3.4. Bolts and Threaded Parts
- 3.5. Special Fabrication and Erection Requirements

3.1. GENERAL

The provisions of this Appendix apply to stresses calculated on the basis of *service loads*. The maximum permitted *stress* due to unfactored *loads* is $0.66F_y$.

Stress range is defined as the magnitude of the change in stress due to the application or removal of the service live load. In the case of a stress reversal, the stress range shall be computed as the numerical sum of maximum repeated tensile and compressive stresses or the numerical sum of maximum shearing stresses of opposite direction at the point of probable crack initiation.

In the case of complete-joint-penetration butt welds, the maximum *design stress range* calculated by Equation A-3-1 applies only to welds with internal soundness meeting the acceptance requirements of Section 6.12.2 or 6.13.2 of AWS D1.1.

No evaluation of *fatigue* resistance is required if the live load stress range is less than the threshold stress range, F_{TH} . See Table A-3.1.

No evaluation of fatigue resistance is required if the number of cycles of application of live load is less than 20,000.

The cyclic load resistance determined by the provisions of this Appendix is applicable to structures with suitable corrosion protection or subject only to mildly corrosive atmospheres, such as normal atmospheric conditions.

The cyclic load resistance determined by the provisions of this Appendix is applicable only to structures subject to temperatures not exceeding 300 °F (150 °C).

The *engineer of record* shall provide either complete details including weld sizes or shall specify the planned cycle life and the maximum range of moments, shears and reactions for the *connections*.

3.2. CALCULATION OF MAXIMUM STRESSES AND STRESS RANGES

Calculated stresses shall be based upon *elastic analysis*. Stresses shall not be amplified by *stress concentration* factors for geometrical discontinuities.

For bolts and threaded rods subject to axial tension, the calculated stresses shall include the effects of *prying action*, if any. In the case of axial stress combined with bending, the maximum stresses, of each kind, shall be those determined for concurrent arrangements of the applied *load*.

For members having symmetric cross sections, the *fasteners* and welds shall be arranged symmetrically about the axis of the member, or the total stresses including those due to eccentricity shall be included in the calculation of the *stress range*.

For axially loaded angle members where the center of gravity of the connecting welds lies between the line of the center of gravity of the angle cross section and the center of the connected leg, the effects of eccentricity shall be ignored. If the center of gravity of the connecting welds lies outside this zone, the total stresses, including those due to *joint eccentricity*, shall be included in the calculation of *stress range*.

3.3. DESIGN STRESS RANGE

The range of *stress* at *service loads* shall not exceed the *design stress range* computed as follows.

- (a) For stress categories A, B, B', C, D, E and E' the design stress range, F_{SR} , shall be determined by Equation A-3-1 or A-3-1M.

$$F_{SR} = \left(\frac{C_f}{N} \right)^{0.333} \geq F_{TH} \quad (\text{A-3-1})$$

$$F_{SR} = \left(\frac{C_f \times 329}{N} \right)^{0.333} \geq F_{TH} \quad (\text{S.I.}) \quad (\text{A-3-1M})$$

where

F_{SR} = design stress range, ksi (MPa)

C_f = constant from Table A-3.1 for the category

N = number of stress range fluctuations in design life

= number of stress range fluctuations per day \times 365 \times years of design life

F_{TH} = threshold *fatigue stress* range, maximum *stress range* for indefinite design life from Table A-3.1, ksi (MPa)

- (b) For stress category F, the design stress range, F_{SR} , shall be determined by Equation A-3-2 or A-3-2M.

$$F_{SR} = \left(\frac{C_f}{N} \right)^{0.167} \geq F_{TH} \quad (\text{A-3-2})$$

$$F_{SR} = \left(\frac{C_f \times 11 \times 10^4}{N} \right)^{0.167} \geq F_{TH} \quad (\text{S.I.}) \quad (\text{A-3-2M})$$

- (c) For tension-loaded plate elements connected at their end by cruciform, T, or corner details with *complete-joint-penetration (CJP) groove welds* or *partial-joint-penetration (PJP) groove welds, fillet welds*, or combinations of the preceding, transverse to the direction of stress, the design stress range on the cross section of the tension-loaded plate element at the toe of the weld shall be determined as follows:

- (i) Based upon crack initiation from the toe of the weld on the tension loaded plate element the design stress range, F_{SR} , shall be determined by Equation A-3-3 or A-3-3M, for stress category C which is equal to

$$F_{SR} = \left(\frac{44 \times 10^8}{N} \right)^{0.333} \geq 10 \quad (\text{A-3-3})$$

$$F_{SR} = \left(\frac{14.4 \times 10^{11}}{N} \right)^{0.333} \geq 68.9 \quad (\text{S.I.}) \quad (\text{A-3-3M})$$

- (ii) Based upon crack initiation from the root of the weld the design stress range, F_{SR} , on the tension loaded plate element using transverse PJP groove welds, with or without reinforcing or contouring fillet welds, the design stress range on the cross section at the toe of the weld shall be determined by Equation A-3-4 or A-3-4M, stress category C' as follows:

$$F_{SR} = R_{PJP} \left(\frac{44 \times 10^8}{N} \right)^{0.333} \quad (\text{A-3-4})$$

$$F_{SR} = R_{PJP} \left(\frac{14.4 \times 10^{11}}{N} \right)^{0.333} \quad (\text{S.I.}) \quad (\text{A-3-4M})$$

where

R_{PJP} is the reduction factor for reinforced or nonreinforced transverse PJP groove welds determined as follows:

$$R_{PJP} = \left(\frac{0.65 - 0.59 \left(\frac{2a}{t_p} \right) + 0.72 \left(\frac{w}{t_p} \right)}{t_p^{0.167}} \right) \leq 1.0$$

$$R_{PJP} = \left(\frac{1.12 - 1.01 \left(\frac{2a}{t_p} \right) + 1.24 \left(\frac{w}{t_p} \right)}{t_p^{0.167}} \right) \leq 1.0 \quad (\text{S.I.})$$

If $R_{PJP} = 1.0$, use stress category C.

$2a$ = the length of the nonwelded root face in the direction of the thickness of the tension-loaded plate, in. (mm)

w = the leg size of the reinforcing or contouring fillet, if any, in the direction of the thickness of the tension-loaded plate, in. (mm)

t_p = thickness of tension loaded plate, in. (mm)

- (iii) Based upon crack initiation from the roots of a pair of transverse fillet welds on opposite sides of the tension loaded plate element the design stress range, F_{SR} , on the cross section at the toe of the welds shall be determined by Equation A-3-5 or A-3-5M, stress category C'' as follows:

$$F_{SR} = R_{FIL} \left(\frac{44 \times 10^8}{N} \right)^{0.333} \quad (\text{A-3-5})$$

$$F_{SR} = R_{FIL} \left(\frac{14.4 \times 10^{11}}{N} \right)^{0.333} \quad (\text{S.I.}) \quad (\text{A-3-5M})$$

where

R_{FIL} is the reduction factor for joints using a pair of transverse fillet welds only.

$$R_{FIL} = \left(\frac{0.06 + 0.72(w/t_p)}{t_p^{0.167}} \right) \leq 1.0$$

$$R_{FIL} = \left(\frac{0.10 + 1.24(w/t_p)}{t_p^{0.167}} \right) \leq 1.0 \quad (\text{S.I.})$$

If $R_{FIL} = 1.0$, use stress category C.

3.4. BOLTS AND THREADED PARTS

The range of *stress* at *service loads* shall not exceed the stress range computed as follows.

- (a) For mechanically fastened *connections* loaded in shear, the maximum range of stress in the connected material at service loads shall not exceed the *design stress range* computed using Equation A-3-1 where C_f and F_{TH} are taken from Section 2 of Table A-3.1.
- (b) For high-strength bolts, common bolts, and threaded anchor rods with cut, ground or rolled threads, the maximum range of tensile stress on the net tensile area from applied axial *load* and moment plus load due to *prying action* shall not exceed the design stress range computed using Equation A-3-1 or A-3-1M. The factor C_f shall be taken as 3.9×10^8 (as for stress category E'). The threshold stress, F_{TH} shall be taken as 7 ksi (48 MPa) (as for stress category D). The net tensile area is given by Equation A-3-6 and A-3-6M.

$$A_t = \frac{\pi}{4} \left(d_b - \frac{0.9743}{n} \right)^2 \quad (\text{A-3-6})$$

$$A_t = \frac{\pi}{4} (d_b - 0.9382P)^2 \quad (\text{S.I.}) \quad (\text{A-3-6M})$$

where

P = *pitch*, in. per thread (mm per thread)

d_b = the nominal diameter (body or shank diameter), in. (mm)

n = threads per in. (threads per mm)

For *joints* in which the material within the *grip* is not limited to steel or joints which are not tensioned to the requirements of Table J3.1 or J3.1M, all axial load and moment applied to the joint plus effects of any *prying action* shall be assumed to be carried exclusively by the bolts or rods.

For joints in which the material within the *grip* is limited to steel and which are tensioned to the requirements of Table J3.1 or J3.1M, an analysis of the relative *stiffness* of the connected parts and bolts shall be permitted to be used to determine the tensile *stress* range in the pretensioned bolts due to the total service live load and moment plus effects of any *prying action*. Alternatively, the stress range in the bolts shall be assumed to be equal to the stress on the net tensile area due to 20 percent of the absolute value of the service load axial load and moment from dead, live and other loads.

3.5. SPECIAL FABRICATION AND ERECTION REQUIREMENTS

Longitudinal backing bars are permitted to remain in place, and if used, shall be continuous. If splicing is necessary for long *joints*, the bar shall be joined with complete penetration butt joints and the reinforcement ground prior to assembly in the joint.

In transverse joints subject to tension, backing bars, if used, shall be removed and the joint back gouged and welded.

In transverse complete-joint-penetration T and corner joints, a reinforcing *fillet weld*, not less than $\frac{1}{4}$ in. (6 mm) in size shall be added at re-entrant corners.

The surface roughness of flame cut edges subject to significant cyclic tensile *stress* ranges shall not exceed 1,000 μ .in. (25 μ .m), where ASME B46.1 is the reference standard.

Reentrant corners at cuts, *cope*s and weld access holes shall form a radius of not less than $\frac{3}{8}$ in. (10 mm) by predrilling or subpunching and reaming a hole, or by thermal cutting to form the radius of the cut. If the radius portion is formed by thermal cutting, the cut surface shall be ground to a bright metal surface.

For transverse butt joints in regions of high tensile stress, run-off tabs shall be used to provide for cascading the weld termination outside the finished joint. End dams shall not be used. Run-off tabs shall be removed and the end of the weld finished flush with the edge of the member.

See Section J2.2b for requirements for *end returns* on certain fillet welds subject to cyclic *service loading*.

TABLE A-3.1
Fatigue Design Parameters

Description	Stress Category	Constant C_f	Threshold F_{TH} ksi (MPa)	Potential Crack Initiation Point
SECTION 1 – PLAIN MATERIAL AWAY FROM ANY WELDING				
1.1 Base metal, except non-coated weathering steel, with rolled or cleaned surface. Flame-cut edges with surface roughness value of 1,000 μ in. (25 μ m) or less, but without reentrant corners.	A	250×10^8	24 (165)	Away from all welds or structural <i>connections</i>
1.2 Non-coated weathering steel base metal with rolled or cleaned surface. Flame-cut edges with surface roughness value of 1,000 μ in. (25 μ m) or less, but without reentrant corners.	B	120×10^8	16 (110)	Away from all welds or structural <i>connections</i>
1.3 Member with drilled or reamed holes. Member with reentrant corners at <i>cope</i> s, cuts, block-outs or other geometrical discontinuities made to requirements of Appendix 3.5, except weld access holes.	B	120×10^8	16 (110)	At any external edge or at hole perimeter
1.4 Rolled cross sections with weld access holes made to requirements of Section J1.6 and Appendix 3.5. Members with drilled or reamed holes containing bolts for attachment of light bracing where there is a small longitudinal component of brace <i>force</i> .	C	44×10^8	10 (69)	At <i>reentrant</i> corner of weld access hole or at any small hole (may contain bolt for minor <i>connections</i>)
SECTION 2 – CONNECTED MATERIAL IN MECHANICALLY FASTENED JOINTS				
2.1 Gross area of base metal in lap joints connected by high-strength bolts in joints satisfying all requirements for slip-critical connections.	B	120×10^8	16 (110)	Through gross section near hole
2.2 Base metal at net section of high-strength bolted joints, designed on the basis of bearing resistance, but fabricated and installed to all requirements for slip-critical connections.	B	120×10^8	16 (110)	In net section originating at side of hole
2.3 Base metal at the net section of other mechanically fastened joints except eye bars and pin plates.	D	22×10^8	7 (48)	In net section originating at side of hole
2.4 Base metal at net section of <i>eyebars</i> head or pin plate.	E	11×10^8	4.5 (31)	In net section originating at side of hole

**TABLE A-3.1 (cont.)
Fatigue Design Parameters**

Illustrative Typical Examples

SECTION 1 – PLAIN MATERIAL AWAY FROM ANY WELDING

1.1 and 1.2

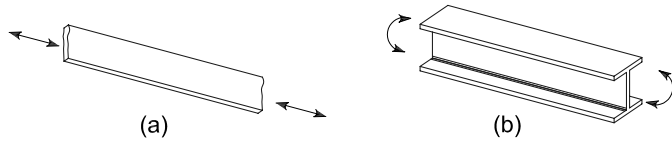

1.3

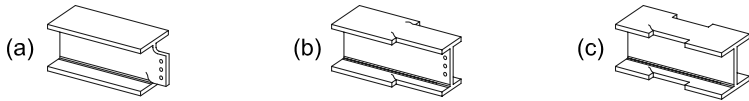

1.4

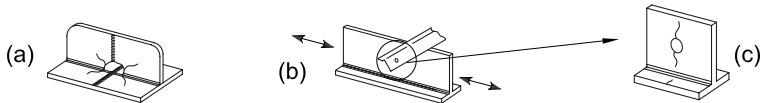

SECTION 2 – CONNECTED MATERIAL IN MECHANICALLY FASTENED JOINTS

2.1

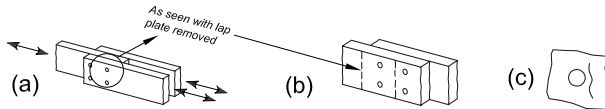

2.2

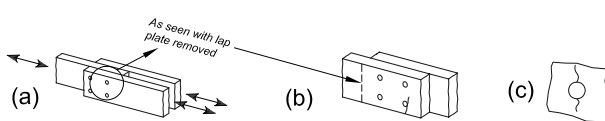

2.3

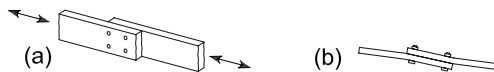

2.4

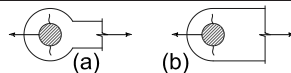

**TABLE A-3.1 (cont.)
Fatigue Design Parameters**

Description	Stress Category	Constant C_f	Threshold F_{TH} ksi (MPa)	Potential Crack Initiation Point
SECTION 3 – WELDED JOINTS JOINING COMPONENTS OF BUILT-UP MEMBERS				
3.1 Base metal and weld metal in members without attachments built-up of plates or shapes connected by continuous longitudinal complete-joint-penetration groove welds, back gouged and welded from second side, or by continuous fillet welds.	B	120×10^8	16 (110)	From surface or internal discontinuities in weld away from end of weld
3.2 Base metal and weld metal in members without attachments built-up of plates or shapes, connected by continuous longitudinal complete-joint-penetration groove welds with backing bars not removed, or by continuous partial-joint-penetration groove welds.	B'	61×10^8	12 (83)	From surface or internal discontinuities in weld, including weld attaching backing bars
3.3 Base metal and weld metal termination of longitudinal welds at weld access holes in connected built-up members.	D	22×10^8	7 (48)	From the weld termination into the web or flange
3.4 Base metal at ends of longitudinal intermittent fillet weld segments.	E	11×10^8	4.5 (31)	In connected material at start and stop locations of any weld deposit
3.5 Base metal at ends of partial length welded coverplates narrower than the flange having square or tapered ends, with or without welds across the ends of coverplates wider than the flange with welds across the ends. Flange thickness ≤ 0.8 in. (20 mm)	E	11×10^8	4.5 (31)	In flange at toe of end weld or in flange at termination of longitudinal weld or in edge of flange with wide coverplates
Flange thickness > 0.8 in. (20 mm)	E'	3.9×10^8	2.6 (18)	
3.6 Base metal at ends of partial length welded coverplates wider than the flange without welds across the ends.	E'	3.9×10^8	2.6 (18)	In edge of flange at end of coverplate weld
SECTION 4 – LONGITUDINAL FILLET WELDED END CONNECTIONS				
4.1 Base metal at junction of axially loaded members with longitudinally welded end connections. Welds shall be on each side of the axis of the member to balance weld stresses. $t \leq 0.8$ in. (20 mm)	E	11×10^8	4.5 (31)	Initiating from end of any weld termination extending into the base metal
$t > 0.8$ in. (20 mm)	E'	3.9×10^8	2.6 (18)	

**TABLE A-3.1 (cont.)
Fatigue Design Parameters**

Illustrative Typical Examples

SECTION 3 – WELDED JOINTS JOINING COMPONENTS OF BUILT-UP MEMBERS

3.1

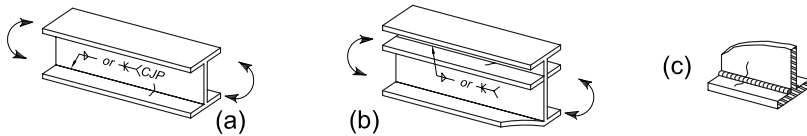

3.2

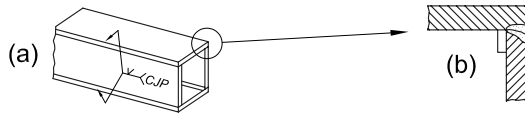

3.3



3.4

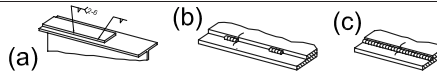

3.5

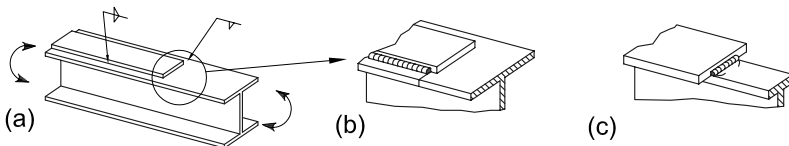

3.6

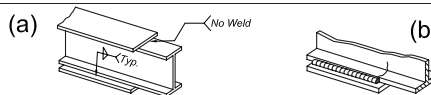

SECTION 4 – LONGITUDINAL FILLET WELDED END CONNECTIONS

4.1

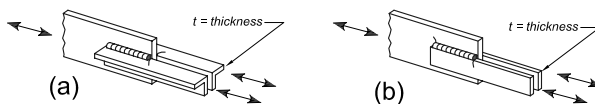

**TABLE A-3.1 (cont.)
Fatigue Design Parameters**

Description	Stress Category	Constant C_f	Threshold F_{TH} ksi (MPa)	Potential Crack Initiation Point
SECTION 5 – WELDED JOINTS TRANSVERSE TO DIRECTION OF STRESS				
5.1 Base metal and weld metal in or adjacent to complete-joint-penetration groove welded splices in rolled or welded cross sections with welds ground essentially parallel to the direction of stress.	B	120×10^8	16 (110)	From internal discontinuities in filler metal or along the fusion boundary
5.2 Base metal and weld metal in or adjacent to complete-joint-penetration groove welded splices with welds ground essentially parallel to the direction of stress at transitions in thickness or width made on a slope no greater than 8 to 20%.				From internal discontinuities in filler metal or along fusion boundary or at start of transition when $F_y \geq 90$ ksi (620 MPa)
$F_y < 90$ ksi (620 MPa)	B	120×10^8	16 (110)	
$F_y \geq 90$ ksi (620 MPa)	B'	61×10^8	12 (83)	
5.3 Base metal with F_y equal to or greater than 90 ksi (620 MPa) and weld metal in or adjacent to complete-joint-penetration groove welded splices with welds ground essentially parallel to the direction of stress at transitions in width made on a radius of not less than 2 ft (600 mm) with the point of tangency at the end of the groove weld.	B	120×10^8	16 (110)	From internal discontinuities in filler metal or discontinuities along the fusion boundary
5.4 Base metal and weld metal in or adjacent to the toe of complete-joint-penetration T or corner joints or splices, with or without transitions in thickness having slopes no greater than 8 to 20%, when weld reinforcement is not removed.	C	44×10^8	10 (69)	From surface discontinuity at toe of weld extending into base metal or along fusion boundary.
5.5 Base metal and weld metal at transverse end connections of tension-loaded plate elements using partial-joint-penetration butt or T or corner joints, with reinforcing or contouring fillets, F_{SR} shall be the smaller of the toe crack or root crack stress range.				Initiating from geometrical discontinuity at toe of weld extending into base metal or, initiating at weld root subject to tension extending up and then out through weld
Crack initiating from weld toe:	C	44×10^8	10 (69)	
Crack initiating from weld root:	C'	Eqn. A-3-4 or A-3-4M	None provided	

**TABLE A-3.1 (cont.)
Fatigue Design Parameters**

Illustrative Typical Examples

SECTION 5 – WELDED JOINTS TRANSVERSE TO DIRECTION OF STRESS

5.1

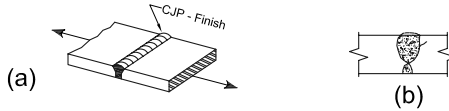

5.2

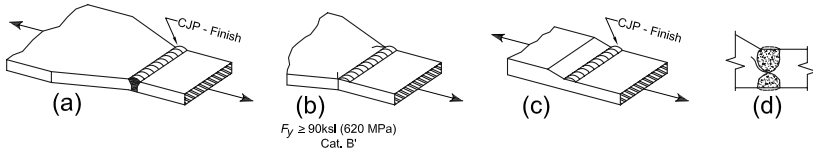

5.3

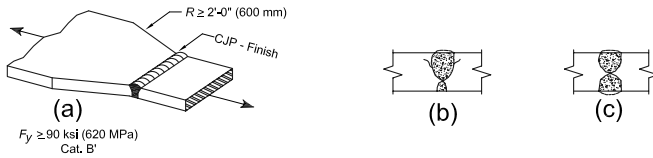

5.4

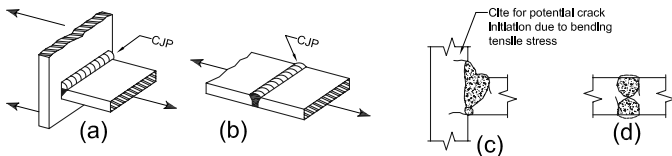

5.5

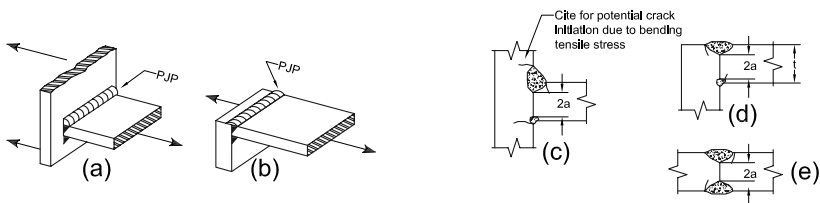

**TABLE A-3.1 (cont.)
Fatigue Design Parameters**

Description	Stress Category	Constant C_f	Threshold F_{TH} ksi (MPa)	Potential Crack Initiation Point
SECTION 5 – WELDED JOINTS TRANSVERSE TO DIRECTION OF STRESS (cont'd)				
5.6 Base metal and filler metal at transverse end connections of tension-loaded plate elements using a pair of fillet welds on opposite sides of the plate. F_{SR} shall be the smaller of the toe crack or root crack stress range. Crack initiating from weld toe:	C	44×10^8	10 (69)	Initiating from geometrical discontinuity at toe of weld extending into base metal or, initiating at <i>weld root</i> subject to tension extending up and then out through weld
	C''	Eqn. A-3-5 or A-3-5M	None provided	
5.7 Base metal of tension loaded plate elements and on girders and rolled beam webs or flanges at toe of transverse fillet welds adjacent to welded transverse stiffeners.	C	44×10^8	10 (69)	From geometrical discontinuity at <i>toe of fillet</i> extending into base metal
SECTION 6 – BASE METAL AT WELDED TRANSVERSE MEMBER CONNECTIONS				
6.1 Base metal at details attached by complete-joint-penetration groove welds subject to longitudinal loading only when the detail embodies a transition radius R with the weld termination ground smooth. $R \geq 24$ in. (600 mm) 24 in. > $R \geq 6$ in. (600 mm > $R \geq 150$ mm) 6 in. > $R \geq 2$ in. (150 mm > $R \geq 50$ mm) 2 in. (50 mm) > R	B	120×10^8	16 (110)	Near point of tangency of radius at edge of member
	C	44×10^8	10 (69)	
	D	22×10^8	7 (48)	
	E	11×10^8	4.5 (31)	

**TABLE A-3.1 (cont.)
Fatigue Design Parameters**

Illustrative Typical Examples

SECTION 5 – WELDED JOINTS TRANSVERSE TO DIRECTION OF STRESS (cont'd)

5.6

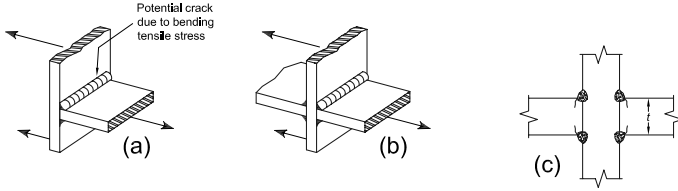

5.7

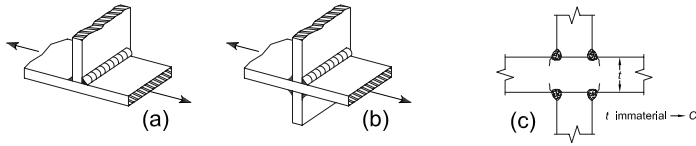

SECTION 6 – BASE METAL AT WELDED TRANSVERSE MEMBER CONNECTIONS

6.1

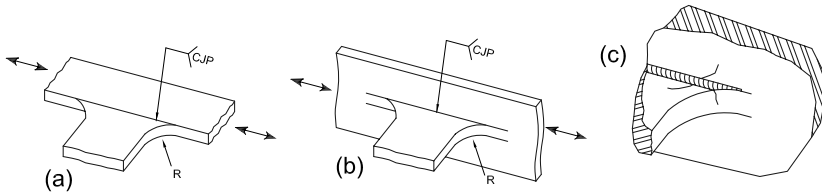

**TABLE A-3.1 (cont.)
Fatigue Design Parameters**

Description	Stress Category	Constant C_f	Threshold F_{TH} ksi (MPa)	Potential Crack Initiation Point		
SECTION 6 – BASE METAL AT WELDED TRANSVERSE MEMBER CONNECTIONS (cont'd)						
<p>6.2 Base metal at details of equal thickness attached by complete-joint-penetration groove welds subject to transverse loading with or without longitudinal loading when the detail embodies a transition radius R with the weld termination ground smooth:</p> <p>When weld reinforcement is removed:</p> <p>$R \geq 24$ in. (600 mm) 24 in. > $R \geq 6$ in. (600 mm > $R \geq 150$ mm)</p> <p>6 in. > $R \geq 2$ in. (150 mm > $R \geq 50$ mm) 2 in. (50 mm) > R</p> <p>When weld reinforcement is not removed:</p> <p>$R \geq 24$ in. (600 mm)</p> <p>24 in. > $R \geq 6$ in. (600 mm > $R \geq 150$ mm) 6 in. > $R \geq 2$ in. (150 mm > $R \geq 50$ mm) 2 in. (50 mm) > R</p>	B	120×10^8	16 (110)	<p>Near points of tangency of radius or in the weld or at fusion boundary or member or attachment</p> <p>At toe of the weld either along edge of member or the attachment</p>		
	C	44×10^8	10 (69)			
	D	22×10^8	7 (48)			
	E	11×10^8	4.5 (31)			
	C	44×10^8	10 (69)			
	C	44×10^8	10 (69)			
	D	22×10^8	7 (48)			
	E	11×10^8	4.5 (31)			
	<p>6.3 Base metal at details of unequal thickness attached by complete-joint-penetration groove welds subject to transverse loading with or without longitudinal loading when the detail embodies a transition radius R with the weld termination ground smooth.</p> <p>When weld reinforcement is removed:</p> <p>$R > 2$ in. (50 mm)</p> <p>$R \leq 2$ in. (50 mm)</p> <p>When reinforcement is not removed: Any radius</p>	D	22×10^8		7 (48)	<p>At toe of weld along edge of thinner material</p> <p>In weld termination in small radius</p> <p>At toe of weld along edge of thinner material</p>
		E	11×10^8		4.5 (31)	
E		11×10^8	4.5 (31)			
E		11×10^8	4.5 (31)			

**TABLE A-3.1 (cont.)
Fatigue Design Parameters**

Illustrative Typical Examples

SECTION 6 – BASE METAL AT WELDED TRANSVERSE MEMBER CONNECTIONS (cont'd)

6.2

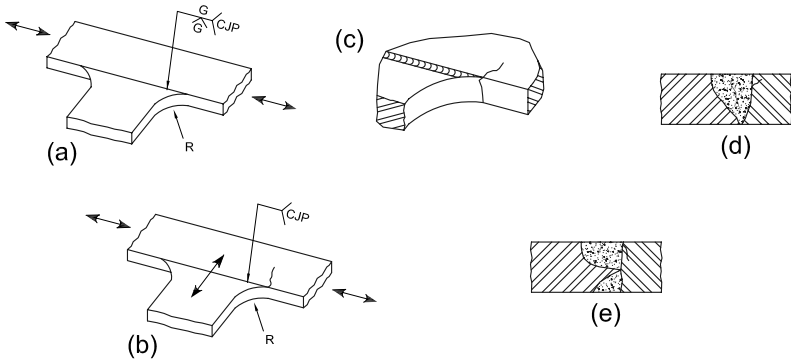

6.3

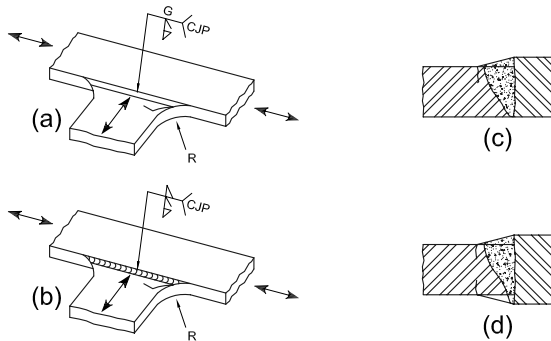

TABLE A-3.1 (cont.)
Fatigue Design Parameters

Description	Stress Category	Constant C_f	Threshold F_{TH} ksi (MPa)	Potential Crack Initiation Point
SECTION 6 – BASE METAL AT WELDED TRANSVERSE MEMBER CONNECTIONS (cont'd)				
6.4 Base metal subject to longitudinal stress at transverse members, with or without transverse stress, attached by fillet or partial penetration groove welds parallel to direction of stress when the detail embodies a transition radius, R , with weld termination ground smooth: $R > 2$ in. (50 mm) $R \leq 2$ in. (50 mm)	D	22×10^8	7 (48)	In weld termination or from the toe of the weld extending into member
	E	11×10^8	4.5 (31)	
SECTION 7 – BASE METAL AT SHORT ATTACHMENTS¹				
7.1 Base metal subject to longitudinal loading at details attached by fillet welds parallel or transverse to the direction of stress where the detail embodies no transition radius and with detail length in direction of stress, a , and attachment height normal to the surface of the member, b : $a < 2$ in. (50 mm) 2 in. (50 mm) $\leq a \leq 12 b$ or 4 in. (100 mm) $a > 12b$ or 4 in. (100 mm) when b is ≤ 1 in. (25 mm) $a > 12b$ or 4 in. (100 mm) when b is > 1 in. (25 mm)	C	44×10^8	10 (69)	In the member at the end of the weld
	D	22×10^8	7 (48)	
	E	11×10^8	4.5 (31)	
	E'	3.9×10^8	2.6 (18)	
7.2 Base metal subject to longitudinal <i>stress</i> at details attached by fillet or partial-joint-penetration groove welds, with or without transverse <i>load</i> on detail, when the detail embodies a transition radius, R , with weld termination ground smooth: $R > 2$ in. (50 mm) $R \leq 2$ in. (50 mm)	D	22×10^8	7 (48)	In weld termination extending into member
	E	11×10^8	4.5 (31)	
¹ "Attachment" as used herein, is defined as any steel detail welded to a member which, by its mere presence and independent of its loading, causes a discontinuity in the <i>stress</i> flow in the member and thus reduces the <i>fatigue</i> resistance.				

**TABLE A-3.1 (cont.)
Fatigue Design Parameters**

Illustrative Typical Examples

SECTION 6 – BASE METAL AT WELDED TRANSVERSE MEMBER CONNECTIONS (cont'd)

6.4

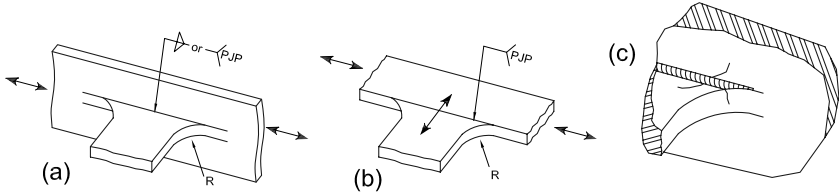

SECTION 7 – BASE METAL AT SHORT ATTACHMENTS

7.1

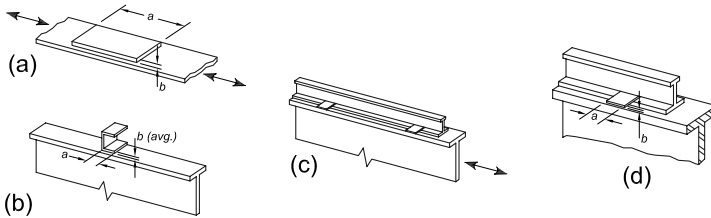

7.2

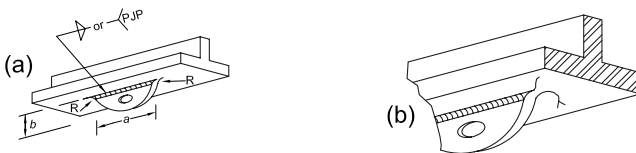

**TABLE A-3.1 (cont.)
Fatigue Design Parameters**

Description	Stress Category	Constant C_f	Threshold F_{TH} ksi (MPa)	Potential Crack Initiation Point
SECTION 8 - MISCELLANEOUS				
8.1 Base metal at stud-type shear connectors attached by fillet or electric stud welding.	C	44×10^8	10 (69)	At toe of weld in base metal
8.2 Shear on throat of continuous or intermittent longitudinal or transverse fillet welds.	F	150×10^{10} (Eqn. A-3-2 or A-3-2M)	8 (55)	In throat of weld
8.3 Base metal at plug or slot welds.	E	11×10^8	4.5 (31)	At end of weld in base metal
8.4 Shear on plug or slot welds.	F	150×10^{10} (Eqn. A-3-2 or A-3-2M)	8 (55)	At <i>faying surface</i>
8.5 Not fully tightened high-strength bolts, common bolts, threaded anchor rods and hanger rods with cut, ground or rolled threads. Stress range on tensile stress area due to live load plus prying action when applicable.	E'	3.9×10^8	7 (48)	At the root of the threads extending into the tensile <i>stress</i> area

**TABLE A-3.1 (cont.)
Fatigue Design Parameters**

Illustrative Typical Examples

SECTION 8 – MISCELLANEOUS

8.1				
8.2				
8.3				
8.4				
8.5				

APPENDIX 4

STRUCTURAL DESIGN FOR FIRE CONDITIONS

This appendix provides criteria for the design and evaluation of *structural steel* components, systems and frames for fire conditions. These criteria provide for the determination of the heat input, thermal expansion and degradation in mechanical properties of materials at elevated temperatures that cause progressive decrease in strength and *stiffness* of structural components and systems at elevated temperatures.

The appendix is organized as follows:

- 4.1. General Provisions
- 4.2. Structural Design for Fire Conditions by Analysis
- 4.3. Design by Qualification Testing

4.1. GENERAL PROVISIONS

The methods contained in this appendix provide regulatory evidence of compliance in accordance with the design applications outlined in this section.

The appendix uses the following terms in addition to the terms in the Glossary.

Active fire protection: Building materials and systems that are activated by a fire to mitigate adverse effects or to notify people to take some action mitigate adverse effects.

Compartmentation: The enclosure of a building space with elements that have a specific fire endurance.

Convective heat transfer: The transfer of thermal energy from a point of higher temperature to a point of lower temperature through the motion of an intervening medium.

Design-basis fire: A set of conditions that define the development of a fire and the spread of combustion products throughout a building or portion thereof.

Elevated temperatures: Heating conditions experienced by building elements or structures as a result of fire, which are in excess of the anticipated ambient conditions.

Fire: Destructive burning, as manifested by any or all of the following: light, flame, heat, or smoke.

Fire barrier: Element of construction formed of fire-resisting materials and tested in accordance with ASTM Standard E119, or other approved standard fire resistance test, to demonstrate compliance with the Building Code.

Fire endurance: A measure of the elapsed time during which a material or assembly continues to exhibit fire resistance.

Fire resistance: That property of assemblies that prevents or retards the passage of excessive heat, hot gases or flames under conditions of use and enables them to continue to perform a stipulated function.

Fire resistance rating: The period of time a building element, component or assembly maintains the ability to contain a fire, continues to perform a given structural function, or both, as determined by test or methods based on tests.

Flashover: The rapid transition to a state of total surface involvement in a fire of combustible materials within an enclosure.

Heat flux: Radiant energy per unit surface area.

Heat release rate: The rate at which thermal energy is generated by a burning material.

Passive fire protection: Building materials and systems whose ability to resist the effects of fire does not rely on any outside activating condition or mechanism.

Performance-based design: An engineering approach to structural design that is based on agreed-upon performance goals and objectives, engineering analysis and quantitative assessment of alternatives against those design goals and objectives using accepted engineering tools, methodologies and performance criteria.

Prescriptive design: A design method that documents compliance with general criteria established in a building code.

Restrained construction: Floor and roof assemblies and individual *beams* in buildings where the surrounding or supporting structure is capable of resisting substantial thermal expansion throughout the range of anticipated elevated temperatures.

Unrestrained construction: Floor and roof assemblies and individual *beams* in buildings that are assumed to be free to rotate and expand throughout the range of anticipated elevated temperatures.

4.1.1. Performance Objective

Structural components, members and building frame systems shall be designed so as to maintain their load-bearing function during the design-basis fire and to satisfy other performance requirements specified for the building occupancy.

Deformation criteria shall be applied where the means of providing structural fire resistance, or the design criteria for fire barriers, requires consideration of the deformation of the load-carrying structure.

Within the compartment of fire origin, *forces* and deformations from the design-basis fire shall not cause a breach of horizontal or vertical compartmentation.

4.1.2. Design by Engineering Analysis

The analysis methods in Section 4.2 are permitted to be used to document the anticipated performance of steel framing when subjected to design-basis fire scenarios. Methods in Section 4.2 provide evidence of compliance with performance objectives established in Section 4.1.1.

The analysis methods in Section 4.2 are permitted to be used to demonstrate an equivalency for an alternative material or method, as permitted by the building code.

4.1.3. Design by Qualification Testing

The qualification testing methods in Section 4.3 are permitted to be used to document the fire resistance of steel framing subject to the standardized fire testing protocols required by building codes.

4.1.4. Load Combinations and Required Strength

The *required strength* of the structure and its elements shall be determined from the following *gravity load combination*:

$$[0.9 \text{ or } 1.2]D + T + 0.5L + 0.2S \quad (\text{A-4-1})$$

where

D = nominal dead load

L = nominal occupancy live load

S = nominal snow load

T = nominal *forces* and deformations due to the design-basis fire defined in Section 4.2.1

A lateral *notional load*, $N_i = 0.002Y_i$, as defined in Appendix 7.2, where N_i = notional *lateral load* applied at framing level i and Y_i = *gravity load* from combination A-4-1 acting on framing level i , shall be applied in combination with the loads stipulated in Equation A-4-1. Unless otherwise stipulated by the *authority having jurisdiction*, D , L and S shall be the *nominal loads* specified in ASCE 7.

4.2. STRUCTURAL DESIGN FOR FIRE CONDITIONS BY ANALYSIS

It is permitted to design structural members, components and building frames for elevated temperatures in accordance with the requirements of this section.

4.2.1. Design-Basis Fire

A design-basis fire shall be identified to describe the heating conditions for the structure. These heating conditions shall relate to the fuel commodities and compartment characteristics present in the assumed fire area. The fuel *load* density based on the occupancy of the space shall be considered when determining the total fuel *load*. Heating conditions shall be specified either in terms of a heat flux or temperature of the upper gas layer created by the fire. The variation of the heating conditions with time shall be determined for the duration of the fire.

When the analysis methods in Section 4.2 are used to demonstrate an equivalency as an alternative material or method as permitted by a building code, the design-basis fire shall be determined in accordance with ASTM E119.

4.2.1.1. Localized Fire

Where the heat release rate from the fire is insufficient to cause flashover, a localized fire exposure shall be assumed. In such cases, the fuel composition, arrangement of the fuel array and floor area occupied by the fuel shall be used to determine the radiant heat flux from the flame and smoke plume to the structure.

4.2.1.2. Post-Flashover Compartment Fires

Where the heat release rate from the fire is sufficient to cause flashover, a post-flashover compartment fire shall be assumed. The determination of the temperature versus time profile resulting from the fire shall include fuel *load*, ventilation characteristics to the space (natural and mechanical), compartment dimensions and thermal characteristics of the compartment boundary.

4.2.1.3. Exterior Fires

The exposure of exterior structure to flames projecting from windows or other wall openings as a result of a post-flashover compartment fire shall be considered along with the radiation from the interior fire through the opening. The shape and length of the flame projection shall be used along with the distance between the flame and the exterior steelwork to determine the heat flux to the steel. The method identified in Section 4.2.1.2 shall be used for describing the characteristics of the interior compartment fire.

4.2.1.4. Fire Duration

The fire duration in a particular area shall be determined by considering the total combustible mass, in other words, fuel *load* available in the space. In the case of either a localized fire or a post-flashover compartment fire, the time duration shall be determined as the total combustible mass divided by the mass loss rate, except where determined from Section 4.2.1.2.

4.2.1.5. Active Fire Protection Systems

The effects of active fire protection systems shall be considered when describing the design-basis fire.

Where automatic smoke and heat vents are installed in nonsprinklered spaces, the resulting smoke temperature shall be determined from calculation.

4.2.2. Temperatures in Structural Systems under Fire Conditions

Temperatures within structural members, components and frames due to the heating conditions posed by the design-basis fire shall be determined by a heat transfer analysis.

Table A-4.2.1
Properties of Steel at Elevated Temperatures

Steel Temperature (°F)[°C]	$k_E = E_m/E$	$k_y = F_{ym}/F_y$	$k_u = F_{um}/F_y$
68 [20]	*	*	*
200 [93]	1.00	*	*
400 [204]	0.90	*	*
600 [316]	0.78	*	*
750 [399]	0.70	1.00	1.00
800 [427]	0.67	0.94	0.94
1000 [538]	0.49	0.66	0.66
1200 [649]	0.22	0.35	0.35
1400 [760]	0.11	0.16	0.16
1600 [871]	0.07	0.07	0.07
1800 [982]	0.05	0.04	0.04
2000 [1093]	0.02	0.02	0.02
2200 [1204]	0.00	0.00	0.00

*Use ambient properties.

4.2.3. Material Strengths at Elevated Temperatures

Material properties at elevated temperatures shall be determined from test data. In the absence of such data, it is permitted to use the material properties stipulated in this section. These relationships do not apply for steels with a *yield strength* in excess of 65 ksi (448 MPa) or concretes with specified compression strength in excess of 8,000 psi (55 MPa).

4.2.3.1. Thermal Elongation

Thermal expansion of structural and reinforcing steels: For calculations at temperatures above 150 °F (65 °C), the coefficient of thermal expansion shall be $7.8 \times 10^{-6}/^{\circ}\text{F}$ ($1.4 \times 10^{-5}/^{\circ}\text{C}$).

Thermal expansion of normal weight concrete: For calculations at temperatures above 150 °F (65 °C), the coefficient of thermal expansion shall be $1.0 \times 10^{-5}/^{\circ}\text{F}$ ($1.8 \times 10^{-5}/^{\circ}\text{C}$).

Thermal expansion of lightweight concrete: For calculations at temperatures above 150 °F (65 °C), the coefficient of thermal expansion shall be $4.4 \times 10^{-6}/^{\circ}\text{F}$ ($7.9 \times 10^{-6}/^{\circ}\text{C}$).

4.2.3.2. Mechanical Properties at Elevated Temperatures

The deterioration in strength and *stiffness* of structural members, components, and systems shall be taken into account in the *structural analysis* of the frame. The values F_{ym} , F_{um} , E_m , f'_{cm} , E_{cm} and ϵ_{cu} at elevated temperature to be used in *structural analysis*, expressed as the ratio with respect to the property at ambient, assumed to be 68 °F (20 °C), shall be defined as in Tables A-4.2.1 and A-4.2.2. It is permitted to interpolate between these values.

Table A-4.2.2
Properties of Concrete at Elevated Temperatures

Concrete Temperature (°F)[°C]	$k_c = f'_{cm} / f'_c$		E_{cm} / E_c	$\epsilon_{cu}(\%)$
	NWC	LWC		LWC
68 [20]	1.00	1.00	1.00	0.25
200 [93]	0.95	1.00	0.93	0.34
400 [204]	0.90	1.00	0.75	0.46
550 [288]	0.86	1.00	0.61	0.58
600 [316]	0.83	0.98	0.57	0.62
800 [427]	0.71	0.85	0.38	0.80
1000 [538]	0.54	0.71	0.20	1.06
1200 [649]	0.38	0.58	0.092	1.32
1400 [760]	0.21	0.45	0.073	1.43
1600 [871]	0.10	0.31	0.055	1.49
1800 [982]	0.05	0.18	0.036	1.50
2000 [1093]	0.01	0.05	0.018	1.50
2200 [1204]	0.00	0.00	0.00	–

For lightweight concrete (LWC), values of ϵ_{cu} shall be obtained from tests.

4.2.4. Structural Design Requirements

4.2.4.1. General Structural Integrity

The structural frame shall be capable of providing adequate strength and deformation capacity to withstand, as a system, the structural actions developed during the fire within the prescribed limits of deformation. The *structural system* shall be designed to sustain local damage with the structural system as a whole remaining stable.

Continuous *load* paths shall be provided to transfer all *forces* from the exposed region to the final point of resistance. The foundation shall be designed to resist the forces and to accommodate the deformations developed during the design-basis fire.

4.2.4.2. Strength Requirements and Deformation Limits

Conformance of the structural system to these requirements shall be demonstrated by constructing a mathematical model of the structure based on principles of structural mechanics and evaluating this model for the internal forces and deformations in the members of the structure developed by the temperatures from the design-basis fire.

Individual members shall be provided with adequate strength to resist the shears, axial forces and moments determined in accordance with these provisions.

Connections shall develop the strength of the connected members or the forces indicated above. Where the means of providing fire resistance requires the consideration of deformation criteria, the deformation of the structural system,

or members thereof, under the design-basis fire shall not exceed the prescribed limits.

4.2.4.3. Methods of Analysis

4.2.4.3a. Advanced Methods of Analysis

The methods of analysis in this section are permitted for the design of all steel building structures for fire conditions. The design-basis fire exposure shall be that determined in Section 4.2.1. The analysis shall include both a thermal response and the mechanical response to the design-basis fire.

The *thermal response* shall produce a temperature field in each structural element as a result of the design-basis fire and shall incorporate temperature-dependent thermal properties of the structural elements and fire-resistive materials as per Section 4.2.2.

The *mechanical response* results in forces and deflections in the structural system subjected to the thermal response calculated from the design-basis fire. The mechanical response shall take into account explicitly the deterioration in strength and *stiffness* with increasing temperature, the effects of thermal expansions and large deformations. Boundary conditions and connection fixity must represent the proposed structural design. Material properties shall be defined as per Section 4.2.3.

The resulting analysis shall consider all relevant *limit states*, such as excessive deflections, connection fractures, and overall or *local buckling*.

4.2.4.3b. Simple Methods of Analysis

The methods of analysis in this section are applicable for the evaluation of the performance of individual members at elevated temperatures during exposure to fire.

The support and restraint conditions (forces, moments and boundary conditions) applicable at normal temperatures may be assumed to remain unchanged throughout the fire exposure.

(1) Tension members

It is permitted to model the thermal response of a tension element using a one-dimensional heat transfer equation with heat input as directed by the design-basis fire defined in Section 4.2.1.

The *design strength* of a tension member shall be determined using the provisions of Chapter D, with steel properties as stipulated in Section 4.2.3 and assuming a uniform temperature over the cross section using the temperature equal to the maximum steel temperature.

(2) Compression members

It is permitted to model the thermal response of a compression element using a one-dimensional heat transfer equation with heat input as directed by the design-basis fire defined in Section 4.2.1.

The design strength of a compression member shall be determined using the provisions of Chapter E with steel properties as stipulated in Section 4.2.3.

(3) Flexural members

It is permitted to model the thermal response of flexural elements using a one-dimensional heat transfer equation to calculate bottom flange temperature and to assume that this bottom flange temperature is constant over the depth of the member.

The design strength of a flexural member shall be determined using the provisions of Chapter F with steel properties as stipulated in Section 4.2.3.

(4) Composite floor members

It is permitted to model the thermal response of flexural elements supporting a concrete slab using a one-dimensional heat transfer equation to calculate bottom flange temperature. That temperature shall be taken as constant between the bottom flange and mid-depth of the web and shall decrease linearly by no more than 25 percent from the mid-depth of the web to the top flange of the *beam*.

The design strength of a *composite* flexural member shall be determined using the provisions of Chapter I, with reduced *yield stresses* in the steel consistent with the temperature variation described under thermal response.

4.2.4.4. Design Strength

The design strength shall be determined as in Section B3.3. The *nominal strength*, R_n , shall be calculated using material properties, as stipulated in Section 4.2.3, at the temperature developed by the design-basis fire.

4.3. DESIGN BY QUALIFICATION TESTING

4.3.1. Qualification Standards

Structural members and components in steel buildings shall be qualified for the rating period in conformance with ASTM E119. It shall be permitted to demonstrate compliance with these requirements using the procedures specified for steel construction in Section 5 of ASCE/SFPE 29.

4.3.2. Restrained Construction

For floor and roof assemblies and individual *beams* in buildings, a restrained condition exists when the surrounding or supporting structure is capable of resisting actions caused by thermal expansion throughout the range of anticipated elevated temperatures.

Steel beams, girders and frames supporting concrete slabs that are welded or bolted to integral framing members (in other words, *columns*, girders) shall be considered restrained construction.

4.3.3. Unrestrained Construction

Steel beams, girders and frames that do not support a concrete slab shall be considered unrestrained unless the members are bolted or welded to surrounding construction that has been specifically designed and detailed to resist actions caused by thermal expansion.

A steel member bearing on a wall in a single span or at the end span of multiple spans shall be considered unrestrained unless the wall has been designed and detailed to resist effects of thermal expansion.

APPENDIX 5

EVALUATION OF EXISTING STRUCTURES

This appendix applies to the evaluation of the strength and *stiffness* under static vertical (gravity) *loads* of existing structures by *structural analysis*, by *load* tests, or by a combination of *structural analysis* and *load* tests when specified by the engineer of record or in the contract documents. For such evaluation, the steel grades are not limited to those listed in Section A3.1. This appendix does not address *load* testing for the effects of seismic *loads* or moving *loads* (vibrations).

The Appendix is organized as follows:

- 5.1. General Provisions
- 5.2. Material Properties
- 5.3. Evaluation by Structural Analysis
- 5.4. Evaluation by Load Tests
- 5.5. Evaluation Report

5.1. GENERAL PROVISIONS

These provisions shall be applicable when the evaluation of an existing steel structure is specified for (a) verification of a specific set of design loadings or (b) determination of the *available strength* of a *load* resisting member or system. The evaluation shall be performed by *structural analysis* (Section 5.3), by *load* tests (Section 5.4), or by a combination of *structural analysis* and *load* tests, as specified in the contract documents. Where *load* tests are used, the *engineer of record* shall first analyze the structure, prepare a testing plan, and develop a written procedure to prevent excessive permanent deformation or catastrophic collapse during testing.

5.2. MATERIAL PROPERTIES

1. Determination of Required Tests

The *engineer of record* shall determine the specific tests that are required from Section 5.2.2 through 5.2.6 and specify the locations where they are required. Where available, the use of applicable project records shall be permitted to reduce or eliminate the need for testing.

2. Tensile Properties

Tensile properties of members shall be considered in evaluation by *structural analysis* (Section 5.3) or *load* tests (Section 5.4). Such properties shall include the *yield stress*, *tensile strength* and *percent elongation*. Where available, certified

mill test reports or certified reports of tests made by the fabricator or a testing laboratory in accordance with ASTM A6/A6M or A568/A568M, as applicable, shall be permitted for this purpose. Otherwise, tensile tests shall be conducted in accordance with ASTM A370 from samples cut from components of the structure.

3. Chemical Composition

Where welding is anticipated for repair or modification of existing structures, the chemical composition of the steel shall be determined for use in preparing a welding procedure specification (WPS). Where available, results from certified mill test reports or certified reports of tests made by the fabricator or a testing laboratory in accordance with ASTM procedures shall be permitted for this purpose. Otherwise, analyses shall be conducted in accordance with ASTM A751 from the samples used to determine tensile properties, or from samples taken from the same locations.

4. Base Metal Notch Toughness

Where welded tension splices in heavy shapes and plates as defined in Section A3.1d are critical to the performance of the structure, the *Charpy V-Notch toughness* shall be determined in accordance with the provisions of Section A3.1d. If the notch toughness so determined does not meet the provisions of Section A3.1d, the *engineer of record* shall determine if remedial actions are required.

5. Weld Metal

Where structural performance is dependent on existing welded *connections*, representative samples of *weld metal* shall be obtained. Chemical analysis and mechanical tests shall be made to characterize the weld metal. A determination shall be made of the magnitude and consequences of imperfections. If the requirements of AWS D1.1 are not met, the *engineer of record* shall determine if remedial actions are required.

6. Bolts and Rivets

Representative samples of bolts shall be inspected to determine markings and classifications. Where bolts cannot be properly identified visually, representative samples shall be removed and tested to determine *tensile strength* in accordance with ASTM F606 or ASTM F606M and the bolt classified accordingly. Alternatively, the assumption that the bolts are ASTM A307 shall be permitted. Rivets shall be assumed to be ASTM A502, Grade 1, unless a higher grade is established through documentation or testing.

5.3. EVALUATION BY STRUCTURAL ANALYSIS

1. Dimensional Data

All dimensions used in the evaluation, such as spans, *column* heights, member spacings, bracing locations, cross section dimensions, thicknesses and *connection* details, shall be determined from a field survey. Alternatively, when available, it

shall be permitted to determine such dimensions from applicable project design or shop drawings with field verification of critical values.

2. Strength Evaluation

Forces (load effects) in members and connections shall be determined by *structural analysis* applicable to the type of structure evaluated. The load effects shall be determined for the *loads* and *factored load combinations* stipulated in Section B2.

The *available strength* of members and connections shall be determined from applicable provisions of Chapters B through K of this Specification.

3. Serviceability Evaluation

Where required, the deformations at *service loads* shall be calculated and reported.

5.4. EVALUATION BY LOAD TESTS

1. Determination of Load Rating by Testing

To determine the *load rating* of an existing floor or roof structure by testing, a test load shall be applied incrementally in accordance with the *engineer of record's* plan. The structure shall be visually inspected for signs of distress or imminent failure at each load level. Appropriate measures shall be taken if these or any other unusual conditions are encountered.

The tested strength of the structure shall be taken as the maximum applied test load plus the in-situ dead load. The live load rating of a floor structure shall be determined by setting the tested strength equal to $1.2D + 1.6L$, where D is the nominal dead load and L is the nominal live load rating for the structure. The nominal live load rating of the floor structure shall not exceed that which can be calculated using applicable provisions of the specification. For roof structures, L_r , S , or R as defined in the Symbols, shall be substituted for L . More severe *load combinations* shall be used where required by *applicable building codes*.

Periodic unloading shall be considered once the *service load* level is attained and after the onset of inelastic structural behavior is identified to document the amount of permanent set and the magnitude of the inelastic deformations. Deformations of the structure, such as member deflections, shall be monitored at critical locations during the test, referenced to the initial position before loading. It shall be demonstrated, while maintaining maximum test load for one hour that the deformation of the structure does not increase by more than 10 percent above that at the beginning of the holding period. It is permissible to repeat the sequence if necessary to demonstrate compliance.

Deformations of the structure shall also be recorded 24 hours after the test loading is removed to determine the amount of permanent set. Because the amount of acceptable permanent deformation depends on the specific structure, no limit is specified for permanent deformation at maximum loading. Where it is not feasible

to load test the entire structure, a segment or zone of not less than one complete bay, representative of the most critical conditions, shall be selected.

2. Serviceability Evaluation

When load tests are prescribed, the structure shall be loaded incrementally to the service load level. Deformations shall be monitored for a period of one hour. The structure shall then be unloaded and the deformation recorded.

5.5. EVALUATION REPORT

After the evaluation of an existing structure has been completed, the *engineer of record* shall prepare a report documenting the evaluation. The report shall indicate whether the evaluation was performed by *structural analysis*, by *load testing* or by a combination of structural analysis and load testing. Furthermore, when testing is performed, the report shall include the loads and load combination used and the load-deformation and time-deformation relationships observed. All relevant information obtained from design drawings, mill test reports and auxiliary material testing shall also be reported. Finally, the report shall indicate whether the structure, including all members and *connections*, is adequate to withstand the *load effects*.

APPENDIX 6

STABILITY BRACING FOR COLUMNS AND BEAMS

This appendix addresses the minimum brace strength and *stiffness* necessary to provide member *strengths* based on the *unbraced length* between braces with an *effective length factor*, K , equal to 1.0.

The appendix is organized as follows:

- 6.1. General Provisions
- 6.2. Columns
- 6.3. Beams

User Note: The requirements for the stability of braced-frame systems are provided in Chapter C. The provisions in this appendix apply to bracing, intended to stabilize individual members.

6.1. GENERAL PROVISIONS

Bracing is assumed to be perpendicular to the members to be braced; for inclined or *diagonal bracing*, the brace strength (*force* or *moment*) and *stiffness* (force per unit displacement or moment per unit rotation) shall be adjusted for the angle of inclination. The evaluation of the stiffness furnished by a brace shall include its member and geometric properties, as well as the effects of *connections* and anchoring details.

Two general types of bracing systems are considered, relative and nodal. A *relative brace* controls the movement of the brace point with respect to adjacent braced points. A *nodal brace* controls the movement at the braced point without direct interaction with adjacent braced points. The *available strength* and stiffness of the bracing shall equal or exceed the required limits unless analysis indicates that smaller values are justified by analysis.

A *second-order analysis* that includes an initial out-of-straightness of the member to obtain brace strength and stiffness is permitted in lieu of the requirements of this appendix.

6.2. COLUMNS

It is permitted to brace an individual *column* at end and intermediate points along its length by either relative or nodal bracing systems. It is assumed that *nodal braces* are equally spaced along the column.

1. Relative Bracing

The required brace strength is

$$P_{br} = 0.004P_r \quad (\text{A-6-1})$$

The required brace *stiffness* is

$$\beta_{br} = \frac{1}{\phi} \left(\frac{2P_r}{L_b} \right) (\text{LRFD}) \quad \beta_{br} = \Omega \left(\frac{2P_r}{L_b} \right) (\text{ASD}) \quad (\text{A-6-2})$$

where

$$\phi = 0.75 (\text{LRFD}) \quad \Omega = 2.00 (\text{ASD})$$

L_b = distance between braces, in. (mm)

For design according to Section B3.3 (LRFD)

P_r = required axial compressive strength using *LRFD load combinations*, kips (N)

For design according to Section B3.4 (ASD)

P_r = required axial compressive strength using *ASD load combinations*, kips (N)

2. Nodal Bracing

The required brace strength is

$$P_{br} = 0.01P_r \quad (\text{A-6-3})$$

The required brace stiffness is

$$\beta_{br} = \frac{1}{\phi} \left(\frac{8P_r}{L_b} \right) (\text{LRFD}) \quad \beta_{br} = \Omega \left(\frac{8P_r}{L_b} \right) (\text{ASD}) \quad (\text{A-6-4})$$

where

$$\phi = 0.75 (\text{LRFD}) \quad \Omega = 2.00 (\text{ASD})$$

For design according to Section B3.3 (LRFD)

P_r = required axial compressive strength using *LRFD load combinations*, kips (N)

For design according to Section B3.4 (ASD)

P_r = required axial compressive strength using *ASD load combinations*, kips (N)

When L_b is less than L_q , where L_q is the maximum *unbraced length* for the required *column force* with K equal to 1.0, then L_b in Equation A-6-4 is permitted to be taken equal to L_q .

6.3. BEAMS

At points of support for *beams*, girders and trusses, restraint against rotation about their longitudinal axis shall be provided. Beam bracing shall prevent the relative displacement of the top and bottom flanges, in other words, twist of the section. Lateral *stability* of beams shall be provided by *lateral bracing*, *torsional bracing* or a combination of the two. In members subjected to *double curvature* bending, the inflection point shall not be considered a brace point.

1. Lateral Bracing

Bracing shall be attached near the compression flange, except for a cantilevered member, where an end brace shall be attached near the top (tension) flange. Lateral bracing shall be attached to both flanges at the brace point nearest the inflection point for beams subjected to double curvature bending along the length to be braced.

1a. Relative Bracing

The required brace strength is

$$P_{br} = 0.008M_r C_d / h_o \quad (\text{A-6-5})$$

The required brace *stiffness* is

$$\beta_{br} = \frac{1}{\phi} \left(\frac{4M_r C_d}{L_b h_o} \right) (\text{LRFD}) \quad \beta_{br} = \Omega \left(\frac{4M_r C_d}{L_b h_o} \right) (\text{ASD}) \quad (\text{A-6-6})$$

where

$$\phi = 0.75 (\text{LRFD}) \quad \Omega = 2.00 (\text{ASD})$$

h_o = distance between flange centroids, in. (mm)

C_d = 1.0 for bending in *single curvature*; 2.0 for double curvature; $C_d = 2.0$ only applies to the brace closest to the inflection point

L_b = laterally *unbraced length*, in. (mm)

For design according to Section B3.3 (LRFD)

M_r = required flexural strength using *LRFD load combinations*, kip-in. (N-mm)

For design according to Section B3.4 (ASD)

M_r = required flexural strength using *ASD load combinations*, kip-in. (N-mm)

1b. Nodal Bracing

The required brace strength is

$$P_{br} = 0.02M_r C_d / h_o \quad (\text{A-6-7})$$

The required brace *stiffness* is

$$\beta_{br} = \frac{1}{\phi} \left(\frac{10M_r C_d}{L_b h_o} \right) (\text{LRFD}) \quad \beta_{br} = \Omega \left(\frac{10M_r C_d}{L_b h_o} \right) (\text{ASD}) \quad (\text{A-6-8})$$

where

$$\phi = 0.75 \text{ (LRFD)} \quad \Omega = 2.00 \text{ (ASD)}$$

For design according to Section B3.3 (LRFD)

M_r = required flexural strength using LRFD load combinations, kip-in. (N-mm)

For design according to Section B3.4 (ASD)

M_r = required flexural strength using ASD load combinations, kip-in. (N-mm)

When L_b is less than L_q , the maximum unbraced length for M_r , then L_b in Equation A-6-8 shall be permitted to be taken equal to L_q .

2. Torsional Bracing

It is permitted to provide either nodal or continuous *torsional bracing* along the *beam* length. It is permitted to attach the bracing at any cross-sectional location and it need not be attached near the compression flange. The *connection* between a torsional brace and the beam shall be able to support the required moment given below.

2a. Nodal Bracing

The required bracing moment is

$$M_{br} = \frac{0.024M_r L}{nC_b L_b} \quad (\text{A-6-9})$$

The required cross-frame or *diaphragm* bracing *stiffness* is

$$\beta_{Tb} = \frac{\beta_T}{\left(1 - \frac{\beta_T}{\beta_{\text{sec}}}\right)} \quad (\text{A-6-10})$$

where

$$\beta_T = \frac{1}{\phi} \left(\frac{2.4LM_r^2}{nEI_y C_b^2} \right) \text{ (LRFD)} \quad \beta_T = \Omega \left(\frac{2.4LM_r^2}{nEI_y C_b^2} \right) \text{ (ASD)} \quad (\text{A-6-11})$$

$$\beta_{\text{sec}} = \frac{3.3E}{h_o} \left(\frac{1.5h_o t_w^3}{12} + \frac{t_s b_s^3}{12} \right) \quad (\text{A-6-12})$$

where

$$\phi = 0.75 \text{ (LRFD)} \quad \Omega = 3.00 \text{ (ASD)}$$

User Note: $\Omega = 1.5^2/\phi = 3.00$ in Equation A-6-11 because the moment term is squared.

L = span length, in. (mm)

n = number of *nodal braced* points within the span

E = modulus of elasticity of steel = 29,000 ksi (200 000 MPa)

I_y = out-of-plane moment of inertia, in.⁴ (mm⁴)

C_b = modification factor defined in Chapter F

t_w = *beam* web thickness, in. (mm)

t_s = web *stiffener* thickness, in. (mm)

b_s = stiffener width for one-sided stiffeners (use twice the individual stiffener width for pairs of stiffeners), in. (mm)

β_T = brace *stiffness* excluding web distortion, kip-in./radian (N-mm/radian)

β_{sec} = web *distortional stiffness*, including the effect of web *transverse stiffeners*, if any, kip-in./radian (N-mm/radian)

For design according to Section B3.3 (LRFD)

M_r = required flexural strength using LRFD load combinations, kip-in. (N-mm)

For design according to Section B3.4 (ASD)

M_r = required flexural strength using ASD load combinations, kip-in. (N-mm)

If $\beta_{sec} < \beta_T$, Equation A-6-10 is negative, which indicates that torsional *beam* bracing will not be effective due to inadequate web distortional stiffness.

When required, the web stiffener shall extend the full depth of the braced member and shall be attached to the flange if the torsional brace is also attached to the flange. Alternatively, it shall be permissible to stop the stiffener short by a distance equal to $4t_w$ from any *beam* flange that is not directly attached to the torsional brace. When L_b is less than L_q , then L_b in Equation A-6-9 shall be permitted to be taken equal to L_q .

2b. Continuous Torsional Bracing

For continuous bracing, use Equations A-6-9, A-6-10 and A-6-13 with L/n taken as 1.0 and L_b taken as L_q ; the bracing moment and stiffness are given per unit span length. The distortional stiffness for an unstiffened web is

$$\beta_{sec} = \frac{3.3Et_w^3}{12h_o} \quad (\text{A-6-13})$$

APPENDIX 7

DIRECT ANALYSIS METHOD

This appendix addresses the *direct analysis method* for structural systems comprised of *moment frames, braced frames, shear walls*, or combinations thereof.

The appendix is organized as follows:

- 7.1. General Requirements
- 7.2. Notional Loads
- 7.3. Design-Analysis Constraints

7.1. GENERAL REQUIREMENTS

Members shall satisfy the provisions of Section H1 with the nominal *column* strengths, P_n , determined using $K = 1.0$. The *required strengths* for members, *connections* and other structural elements shall be determined using a second-order *elastic analysis* with the constraints presented in Section 7.3. All component and *connection* deformations that contribute to the lateral displacement of the structure shall be considered in the analysis.

7.2. NOTIONAL LOADS

Notional loads shall be applied to the lateral framing system to account for the effects of geometric imperfections, inelasticity, or both. *Notional loads* are *lateral loads* that are applied at each framing level and specified in terms of the *gravity loads* applied at that level. The *gravity load* used to determine the *notional load* shall be equal to or greater than the *gravity load* associated with the *load combination* being evaluated. *Notional loads* shall be applied in the direction that adds to the destabilizing effects under the specified *load combination*.

7.3. DESIGN-ANALYSIS CONSTRAINTS

- (1) The *second-order analysis* shall consider both P - δ and P - Δ *effects*. It is permitted to perform the analysis using any general second-order analysis method, or by the amplified *first-order analysis* method of Section C2, provided that the B_1 and B_2 factors are based on the reduced *stiffnesses* defined in Equations A-7-2 and A-7-3. Analyses shall be conducted according to the design and loading requirements specified in either Section B3.3 (LRFD) or Section B3.4 (ASD). For ASD, the second-order analysis shall be carried out under 1.6 times the ASD *load combinations* and the results shall be divided by 1.6 to obtain the *required strengths*.

Methods of analysis that neglect the effects of $P-\delta$ on the lateral displacement of the structure are permitted where the axial *loads* in all members whose flexural stiffnesses are considered to contribute to the lateral *stability* of the structure satisfy the following limit:

$$\alpha P_r < 0.15 P_{eL} \quad (\text{A-7-1})$$

where

P_r = required axial compressive strength under LRFD or ASD *load combinations*, kips (N)

$P_{eL} = \pi^2 EI/L^2$, evaluated in the plane of bending

and

$$\alpha = 1.0 \text{ (LRFD)} \quad \alpha = 1.6 \text{ (ASD)}$$

- (2) A *notional load*, $N_i = 0.002Y_i$, applied independently in two orthogonal directions, shall be applied as a *lateral load* in all load combinations. This load shall be in addition to other lateral loads, if any,

where

N_i = notional lateral load applied at level i , kips (N)

Y_i = *gravity load* from the *LRFD load combination* or 1.6 times the ASD load combination applied at level i , kips (N)

The notional load coefficient of 0.002 is based on an assumed initial story out-of-plumbness ratio of 1/500. Where a smaller assumed out-of-plumbness is justified, the notional load coefficient may be adjusted proportionally.

For frames where the ratio of second-order drift to first-order drift is equal to or less than 1.5, it is permissible to apply the notional load, N_i , as a minimum lateral load for the gravity-only load combinations and not in combination with other lateral loads.

For all cases, it is permissible to use the assumed out-of-plumbness geometry in the analysis of the structure in lieu of applying a notional load or a minimum lateral load as defined above.

User Note: The unreduced stiffnesses (EI and AE) are used in the above calculations. The ratio of second-order drift to first-order drift can be represented by B_2 , as calculated using Equation C2-3. Alternatively, the ratio can be calculated by comparing the results of a second-order analysis to the results of a first-order analysis, where the analyses are conducted either under LRFD load combinations directly or under ASD load combinations with a 1.6 factor applied to the ASD gravity loads.

- (3) A reduced flexural *stiffness*, EI^* ,

$$EI^* = 0.8\tau_b EI \quad (\text{A-7-2})$$

shall be used for all members whose flexural stiffness is considered to contribute to the lateral *stability* of the structure,

where

I = moment of inertia about the axis of bending, in.⁴ (mm⁴)

$\tau_b = 1.0$ for $\alpha P_r/P_y \leq 0.5$

$= 4[\alpha P_r/P_y (1 - \alpha P_r/P_y)]$ for $\alpha P_r/P_y > 0.5$

P_r = required axial compressive strength under *LRFD* or *ASD load combinations*, kips (N)

$P_y = AF_y$, member *yield strength*, kips (N)

and

$$\alpha = 1.0 \text{ (LRFD)} \quad \alpha = 1.6 \text{ (ASD)}$$

In lieu of using $\tau_b < 1.0$ where $\alpha P_r/P_y > 0.5$, $\tau_b = 1.0$ may be used for all members, provided that an additive *notional load* of $0.001Y_i$ is added to the notional load required in (2).

(4) A reduced axial *stiffness*, EA^* ,

$$EA^* = 0.8EA \tag{A-7-3}$$

shall be used for members whose axial stiffness is considered to contribute to the lateral *stability* of the structure, where A is the cross-sectional member area.