

# Flotek Wind Tunnels



**Low turbulence.  
Research grade.  
Computer compatible.**

*The GDJ range of computer compatible wind tunnels offers an excellent route to the study of aerodynamics.*

The equipment is extremely student friendly and a range of highly visual demonstrations and investigations is available. In addition to airfoils and plates, demonstrations such as drag and slipstream effects of racing cars, and drag due to dimples on a golf ball, are available.

## FEATURES

- *Three sizes, 5" x 5" (127 x 127mm), 6" x 6" (152 x 152mm) and 12" x 12" (305 x 305mm)*
- *Excellent flow patterns in test section*
- *Viewable test section with clear acrylic sides and top*
- *Range of visual demonstrations available*
- *Manual or computer linked instrumentation systems available*

## GENERAL DESCRIPTION

This range of computer compatible wind tunnels is simple and safe in operation. The two smaller units are supplied suitable for bench top operation and the larger unit is supplied complete with floor standing frame.

The air enters the test section through a carefully designed flow straightening system, which ensures that stable, and accurate laminar flow conditions are achieved in the test sections.

The test sections themselves are easily accessible and removable. The panels are manufactured from clear acrylic, which gives excellent visibility of the models during the tests.

**GDJ INC.**

# Flotek 250

## FLOTEK 250 - SMALL LABORATORY WIND TUNNEL

### DESCRIPTION

The smallest of the range is the 250 Wind Tunnel, which is designed to be installed on a laboratory bench. Less than 8' (1.9m) long, it still offers a working section of more than 18" (450mm) long and 5" (125mm) square, allowing a variety of realistic demonstrations to be performed.

A set of airfoils are available as optional accessories, allowing the flow over both upper and lower surfaces to be measured and compared with theory. Also available is a very popular golf ball demonstration, which allows the students to investigate the effect of dimples on the ball. This very practical and highly visual demonstration is an excellent introduction to the effect of aerodynamics in a real world situation.

### SPECIFICATION

Entrance cone:	18" x 18" (457mm square) with a 12:1 contraction ratio
Test section:	5" x 5" x 18" (127mm x 127mm x 457mm) long
Air velocity:	variable up to 72 fps (22m/s)
Overall length:	74" (1880mm)
Motor:	1/8 HP AC, variable speed

### INSTRUMENT OPTIONS

C250-13	16 tube manometer for manual readings
C250-14	8-channel A/D, 2-channel D/A data acquisition card. Eight 0-10" H <sub>2</sub> O pressure sensors. With Labview software. Capable of eight channels, real time data or log to disk. Computer controlled motor speed.

### OPTIONAL MODELS

C250-21a	NACA 2415 airfoil with eight pressure tapings - manually controlled
C250-21b	NACA 2415 airfoil with eight pressure tapings - computer controlled with C250-14 option
C250-22	Additional NACA 0015 airfoil
C250-23	Additional NACA 4415 airfoil
C250-24	Flat plate airfoil
C250-31	Golf ball experiment - Demonstrates of the effect of dimples on a golf ball
C250-33	Rocket sting experiment Allows the students to evaluate rocket performance and the effect of fin positioning

### ORDERING SPECIFICATION

A small scale laboratory wind tunnel suitable for bench top operation. Air is drawn through the entrance cone into the test section by a variable speed fan. A plastic honeycomb flow straightener with an L:D ratio of 10:1, assures a laminar air flow through the test section. The entrance cone has a contraction ratio of 12:1, down to a test section measuring 5" x 5" x 18" long. The air velocity through the test section is variable up to 82 fps (25m/s).

The test section has clear acrylic side walls and top to give a clear observation of the test in progress. The other flow sections are fabricated from 14 gauge steel formed sections.

A series of accessories are available for laboratory demonstrations to provide hands-on, visual learning. A further accessory allows the system to be connected to a user supplied computer, and includes an interface card and Labview software.

# Flotek 360

## FLOTEK 360 - LABORATORY WIND TUNNEL

### DESCRIPTION

The 360 is similar to the 250 but provides a test section of greater cross section. It can be bench top mounted, or an optional mobile stand is available.

In addition to the standard airfoil demonstrations and the golf ball demonstration, the larger test section allows a wider range of demonstrations to be undertaken, including a racing car demonstration and airflow patterns around buildings.

The 360 includes a 16 tube manometer bank as standard equipment.

### SPECIFICATION

Entrance cone:	21" x 21" (533mm square) with a 12:1 contraction ratio
Test section:	6" x 6" x 18" (52mm x 152mm x 457mm) long
Air velocity:	variable up to 88 fps (27m/s)
Overall length:	84" (2140mm)
Motor:	1/2 HP DC, variable speed

### INSTRUMENT OPTIONS

C360-14:	8-channel A/D, 2-channel D/A data acquisition card. Eight 0-10" H <sub>2</sub> O pressure sensors. With Labview software. Capable of eight channels, real time data or log to disk. Computer controlled motor speed and airfoil angle of attack.
----------	--

### OPTIONAL MODELS

C360-21a	NACA 2415 airfoil with eight pressure tapings - manually controlled
C360-21b	NACA 2415 airfoil with eight pressure tapings - computer controlled with C360-14 option
C360-22	Additional NACA 0015 airfoil to be used with C13-21
C360-23	Additional NACA 4415 airfoil to be used with C13-21
C360-24	Flat plate to be used with C13-21
C360-31	Golf ball experiment - Demonstrates of the effect of dimples on a golf ball
C360-33	Rocket sting experiment Allows the student to evaluate rocket performance and the effect of fin positioning
C360-34	Racing car demonstration A model racing car, fitted with pressure tapings. The wind velocity and drag profile can be measured. Two other non-instrumented model cars are provided. These can be positioned around the instrumented car to allow students to investigate drafting and slipstreaming effects
C360-35	Buildings demonstration Allows the student to construct simple model buildings from Lego bricks, and to study the effect on wind velocity and air turbulence

# Flotek 360

## ACCESSORIES

C360-41

Mobile stand.

The 360 can be installed on the 360-41 mobile stand, which allows it to be easily moved about the laboratory, and from one room to another. The stand includes a shelf which can be used for a computer.

## ORDERING SPECIFICATION

A small scale laboratory wind tunnel suitable for bench top operation. Air is drawn through the entrance cone into the test section by a variable speed fan. A plastic honeycomb flow straightener with an L:D ratio of 10:1, ensures a laminar air flow through the test section. The entrance cone has a contraction ratio of 12:1, down to a test section measuring 6" x 6" x 18" (152mm x 152mm x 457mm) long. The air velocity through the test section is variable up to 27m/s.

The test section has clear acrylic side walls and top to give a clear observation of the test in progress. The other flow sections are fabricated from 11 gauge steel formed sections.

A range of accessories are available for laboratory demonstrations. A further accessory allows the system to be connected to a user supplied computer and includes an interface card and Labview software.

NACA 0015 Airfoil - Velocity: 75 fps

KEY	DATA	THEORY
upper surface	□	—
lower surface	●	- - - -

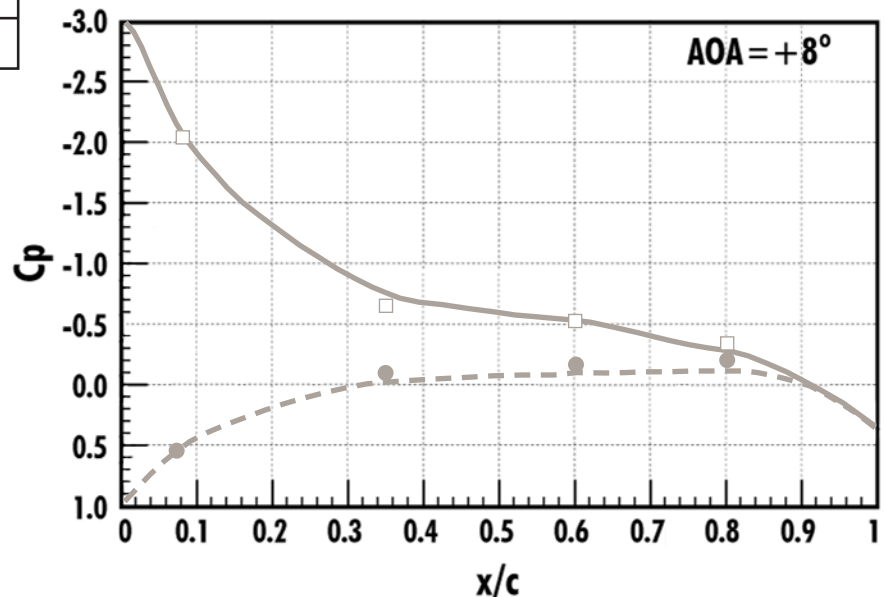
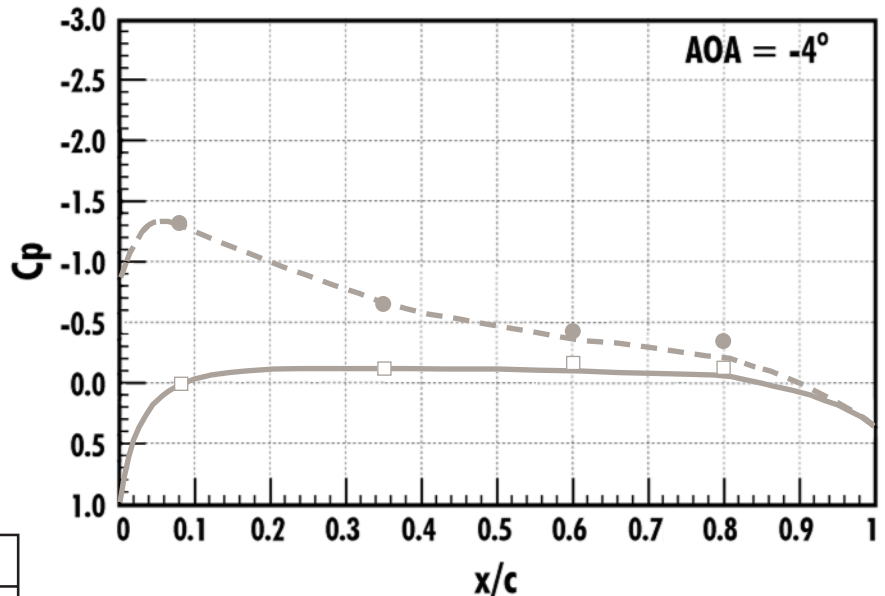

# Flotek 1440

## FLOTEK 1440 - LARGER SCALE WIND TUNNEL

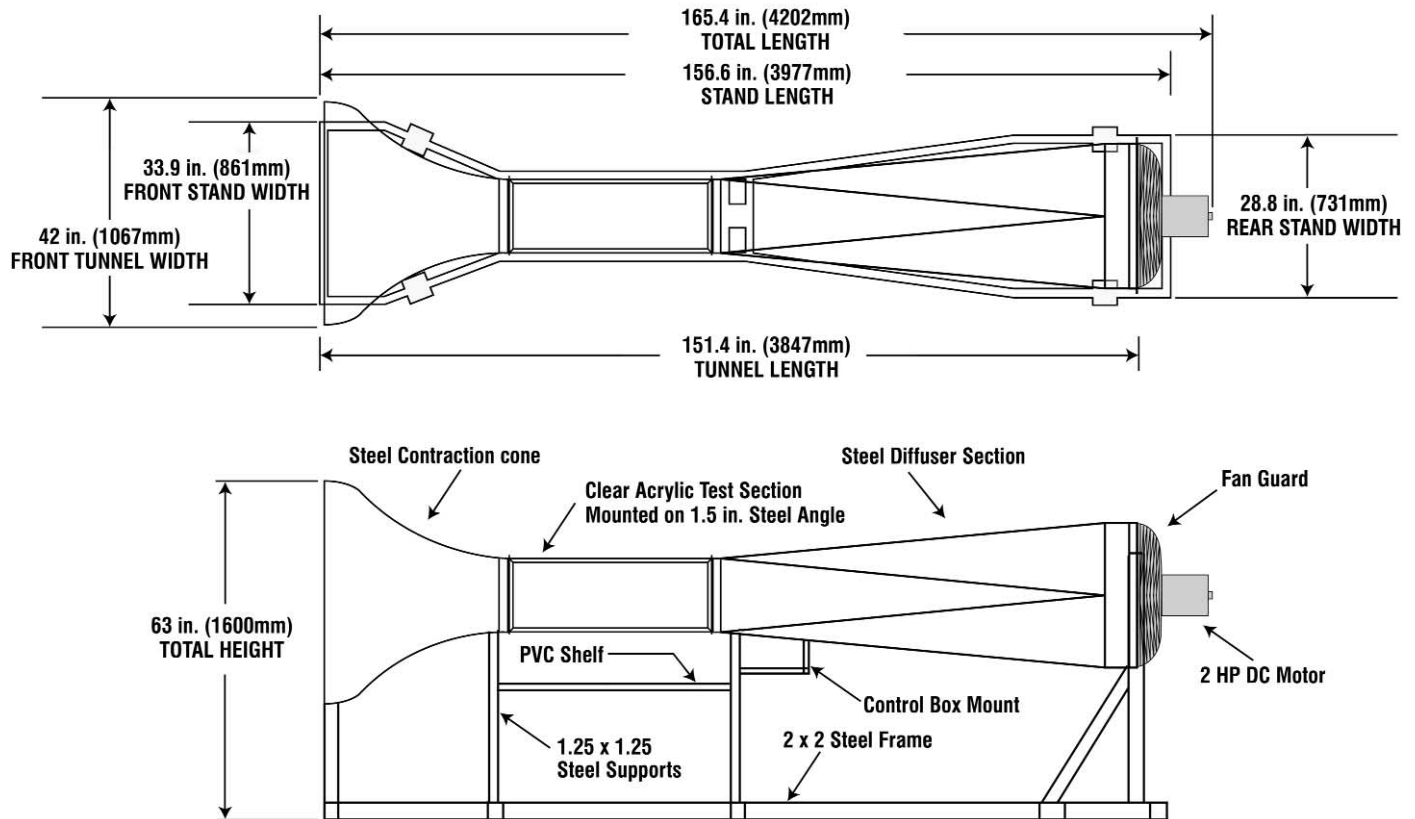

### DESCRIPTION

The FLOTEK 1440 has become our most popular research grade wind tunnel for university engineering and technology programs. This provides a full 12" x 12" (300mm square) cross section in the working area over 36" (900mm) in length. It also has a higher air velocity capacity. This extra flexibility, coupled with the excellent flow patterns obtained, make the 1440 particularly suitable for research use as well as laboratory teaching.

It is a floor standing unit, with its own integral support structure.

Larger test section allows larger models with more data points.

### SPECIFICATION

Entrance cone:	42" x 42" (1067mm square) with a 12:1 contraction ratio
Test section:	12" x 12" x 36" (305mm x 305mm x 914mm) long
Air velocity:	variable up to 132 fps (40m/s)
Overall length:	165.4" (4.2m)

### INSTRUMENT OPTIONS

C1440-15	20 tube manometer for manual readings
C1440-16	16-channel A/D, 2-channel D/A data acquisition card. Sixteen 0-10" H <sub>2</sub> O pressure sensors. With Labview software. Capable of sixteen channels, real time data or log to disk. Computer controlled motor speed and airfoil angle of attack.
C1440-17	Digital rpm readout allows direct readout of the motor rpm

# Flotek 1440

## OPTIONAL MODELS

- C1440-21a NACA 2415 airfoil with eight pressure tappings - manually controlled
- C1440-21b NACA 2415 airfoil with eight pressure tappings - computer controlled with C1440-14 option
- C1440-22 Additional NACA 0015 airfoil to be used with C14-21
- C1440-23 Additional NACA 4415 airfoil to be used with C14-21
- C1440-24 Flat plate to be used with C14-21
- C1440-30 2-component beam balance  
10 - 500 gram equivalent sensitivity
- C1440-31 Golf ball experiment - Demonstrates of the effect of dimples on a golf ball
- C1440-34 Racing car demonstration  
A model racing car, fitted with pressure tappings. The wind velocity and drag profile can be measured. Two other non-instrumented model cars are provided. These can be positioned around the instrumented car to allow students to investigate drafting and slipstreaming effects. With 2-component beam balance can measure frontal and lateral forces.
- C1440-35 Buildings demonstration  
Allows the student to construct simple model buildings from Lego bricks, and to study the effect on wind velocity and air turbulence
- C1440-36 Venturi fluid flow studies  
Two sets of plates with 10 degree and 15 degree divergent angles, to illustrate the continuity law, laminar flow and flow separation.

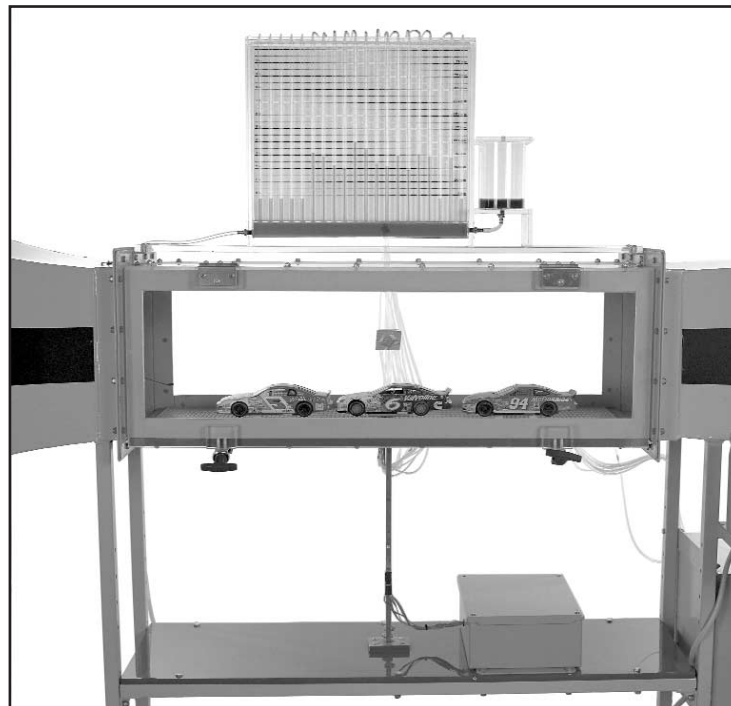

C1440-34 Racing car demonstration, center car mounted on 2-component beam balance with pressure taps

# Flotek 1440

## ORDERING SPECIFICATION

A laboratory wind tunnel suitable for bench top operation. Air is drawn through the entrance cone into the test section by a variable speed fan. A plastic honeycomb flow straightener with an L:D ratio of 10:1, assures a laminar air flow through the test section. The entrance cone has a contraction ratio of 12:1, down to a test section measuring 12" x 12" x 36" (305mm x 305mm x 914mm) long. The air velocity through the test section is variable up to 132 fps (40m/s).

The test section has clear acrylic side walls and top to give a clear observation of the test in progress. The other flow sections are fabricated from 11 gauge steel formed sections.

A range of accessories is available for laboratory demonstrations. A further accessory allows the system to be connected to a user supplied computer, and includes an interface card and Labview software.

## SERVICES REQUIRED

C250-A	220/240V single phase 50Hz
C250-B	110V single phase 60Hz
C360-A	220/240V single phase 50Hz
C360-B	110V single phase 60Hz
C1440-A	220/240V single phase 50Hz
C1440-G	220V single phase 60Hz

## SHIPPING SPECIFICATION

C250	Volume 1m <sup>3</sup> Weight 100Kg
C360	Volume 1.8m <sup>3</sup> Weight 150Kg
C1440	Volume 12m <sup>3</sup> Weight 500Kg

# Flotek

## Flotek 1440 Fan Guard

### Safety

Safety in the laboratory and the classroom is a primary concern. Flotek wind tunnels feature solid construction and industrial quality components for safety and reliability.

Electrical power cabling is fully encased in the frame. Flotek's fan unit is fully recessed behind the guard. And because of Flotek's advanced aerodynamic design, its operation is quiet too.

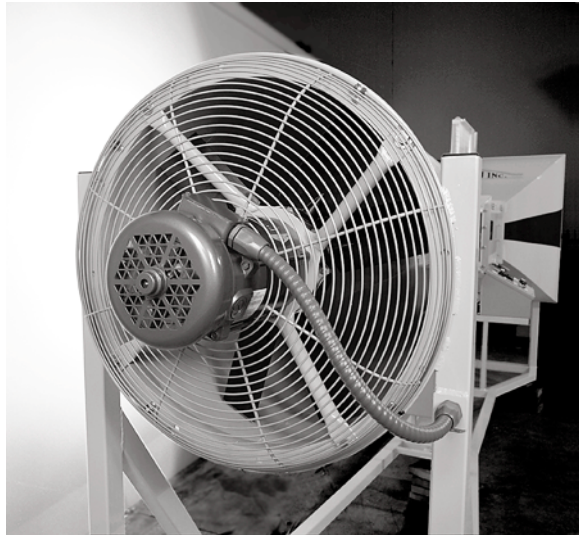

## Computer Data Acquisition System Options

The computer data acquisition system utilizes National Instruments Labview software. The data can be viewed real time on the computer screen or data logged to disk onto an Excel spreadsheet. The latest version of the software allows the user the option to choose screen units between Imperial Units (Feet per second) or S.I. Units (meters per second). The software is provided in two formats: an executable only version, which does not require running Labview software or in VI source code format to allow changes in the screen format if desired. The sophistication of the system does not end with data retrieval; the wind tunnel motor speed and airfoil angle of attack can be controlled from the computer screen as well. This computer controlled feature allows the possibility of being operated via the internet for distance learning classrooms.

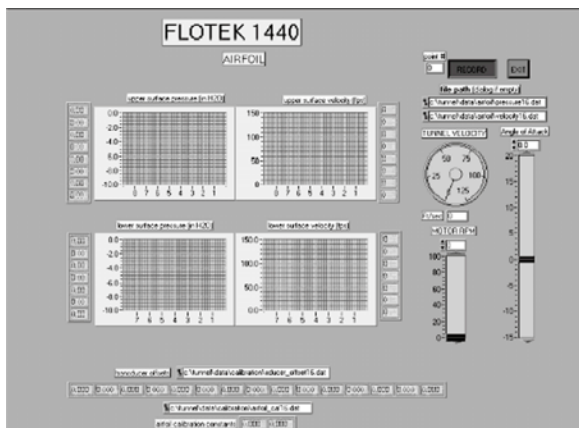

# GDJ INC.

7585 Tyler Boulevard  
Mentor, OH 44060

Phone: 440-975-0258  
E-mail: [jgilbert@gdjinc.com](mailto:jgilbert@gdjinc.com)  
Internet: [www.gdjinc.com](http://www.gdjinc.com)